

---

**User's  
Manual**

**Model DX102P/DX104P/DX106P/DX112P  
DAQSTATION DX100P**

---



### Setting Items in the Engineering Mode

Soft key	Title	Item	Ref. section
#1	Range	Input type, span, scale, etc.	5.1
	Alarm	Alarm type, Alarm value, Output relay On/Off Output relay number	5.2
#2	Tag	Tag name	5.3
	Filter	Filter time constant/Off (DX102P/DX104P)	5.4
	Moving average	Number of samples for the moving average/Off (DX106P/DX112P)	5.4
	Alarm delay time		5.5
#3	Trend/Save interval	Trend display update rate, Auto save interval	5.6
	USER key	Assign an action to the USER key	5.8
#4	Message	Group name and message strings	5.16
#5	Display		
#5 - #1	Group set/Trip line	Group name, Assign channels to groups Trip line position, display color	5.9
	#5 - #2	Color	Measurement channel display color
#5 - #3	Zone	Zone upper and lower limits	5.11
	Graph	Number of scale divisions for the trend and bar graph, Bar graph base position, Scale display position for trends	5.12
Partial	Turn On/Off partial expanded display	Position and boundary for the partial expanded display	5.11
	View	Display direction (trend, bar graph), Background color, Trend line width, Trip line width, Grid for the trend display, Interval for switching group displays (Scroll time), Scale digit LCD brightness	5.13
LCD	Turn On/Off the LCD backlight saver	Transition time for the LCD backlight saver and conditions that restore the backlight	5.14
	File	Header string to be written to file Name of directory to which data are to be saved	5.7
#8	Time	Set the date and time	5.15
#9	Batch set	Use/Not lot number, Auto increment of lot number, Headers 1 to 3	5.17

#7: [Save/Load] operations. #10 to #16: [Math set 1], [Math set 2], [Math set 3], [Calibration Correction], [DST], [End], and [System Mode] are assigned.

FOLD ALONG THIS LINE

## Quick

## Reference

Model DX102P/DX104P  
DX106P/DX112P

## DAQSTATION DX100P

Use this quick reference together with the user's manual IM 04L05A01-01E.

### Operation Screens (see section 1.3)

Trend / Digital/Bar graph / Information (Alarm Summary / Alarm ACK Summary / Message Summary / Memory Summary) / Historical Trend / 4 Screen Display / Sign Record Screen

### Switching Operation Screens (see chapter 7)



Press the DISP/ENTER key to display the screen menu or the operation screen.  
Press the up, down, right, or left arrow key to select the operation screen.

### Sampling Interval and Sampling length for Display Data and Event Data (see appendix 4)

- When Acquiring the display data from four measurement channels

Display Update Rate	15 s	1 min	5 min	15 min	30 min	1 h	4 h	10 h
Sampling Interval (s)	0.5	2	10	30	60	120	480	1200
Sampling length (approx.)	28 h	115 h	12 days	72 days	144 days	289days	1157 days	2893 days

- When Acquiring the event data from four measurement channels

Sampling Interval (s)	125 ms	500 ms	1 s	5 s	30 s	120 s	600 s
Sampling length (approx.)	10 h	43 h	86 h	18 days	108 days	434 days	2170 days

## Flow of operation (an example)

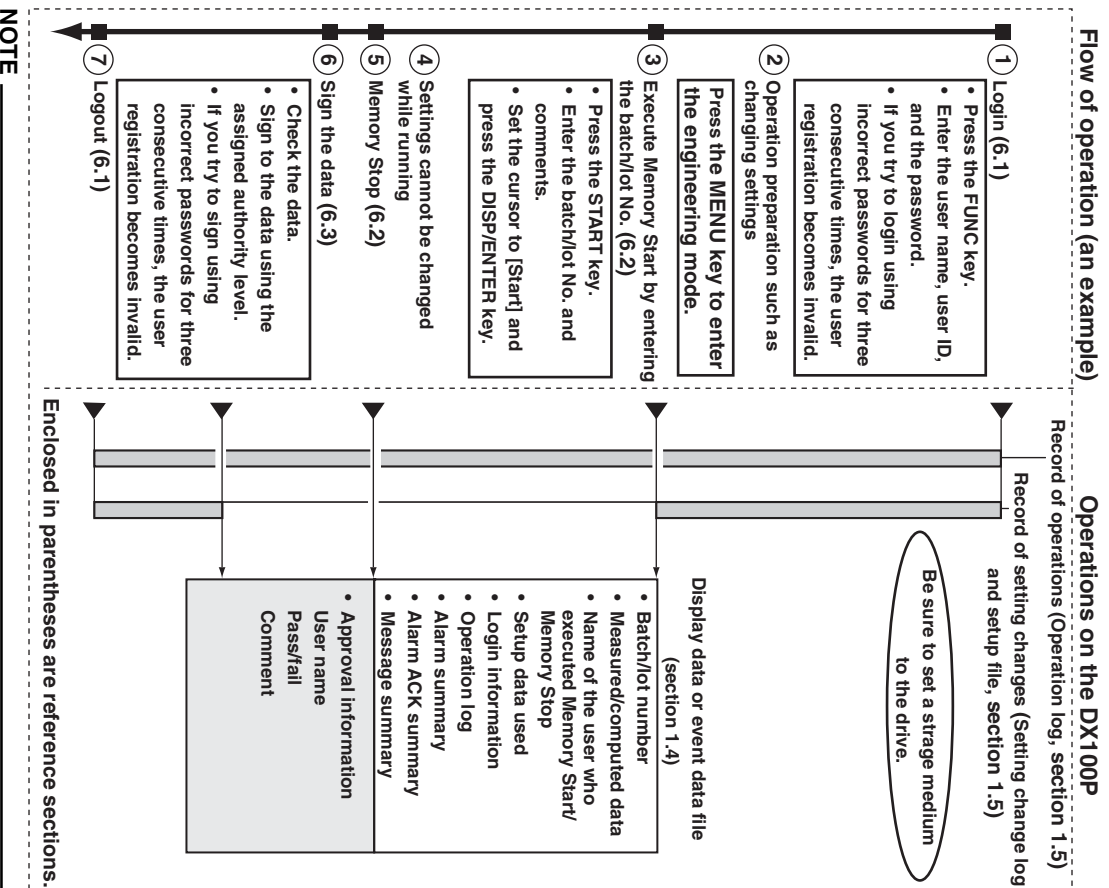

**NOTE**

To avoid injury, death of personnel or damage to the instrument, the operator must refer to the explanation in the User's Manual or Service Manual.

## key function (see section 3.4)

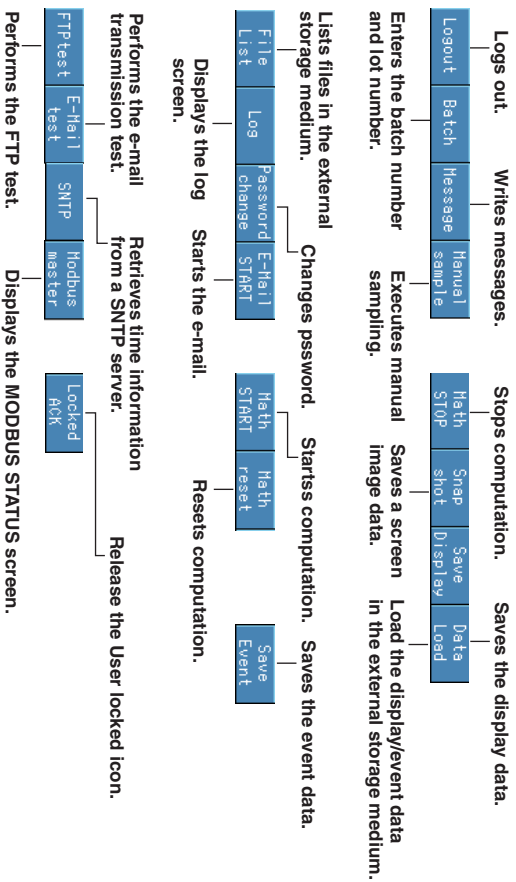

## Switching the Mode (see section 3.3)

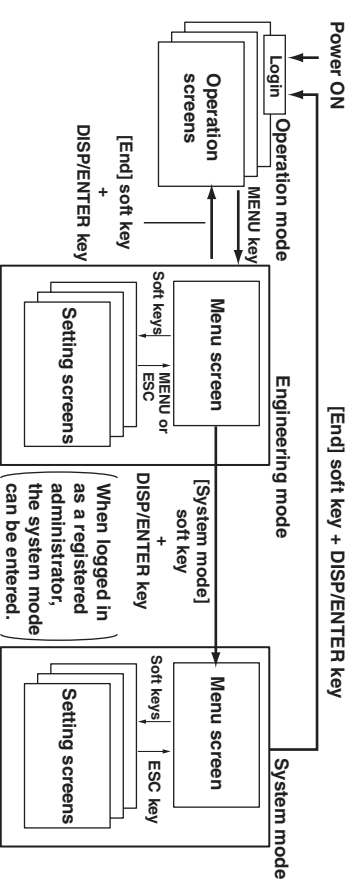

---

## Foreword

Thank you for purchasing the YOKOGAWA DAQSTATION DX100P.

This User's Manual contains useful information about the functions, installation, wiring, operating procedures, and troubleshooting of the DX100P. To ensure correct use, please read this manual thoroughly before operation.

Keep this manual in a safe place for quick reference in the event a question arises.

In addition, a quick reference is provided on the previous page. This reference briefly explains operations that are used frequently. Separate this reference from the manual for use.

The following four manuals, including this one, are provided as manuals for the DX100P.

Manual Name	Manual No.	Description
DX100P User's Manual	IM 04L05A01-01E	This manual. Explains all functions and procedures of the DX100P excluding the communication functions.
DX100P/DX200P Operation Guide	IM 04L05A01-02E	Briefly explains basic operations of the DX100P/DX200P.
DX100P/DX200P Communication Interface User's Manual	IM 04L05A01-17E	Explains the communication functions of the Ethernet/serial interface.
DAQSIGNIN User's Manual	IM 04L05A01-61E	Describes the functions and operating procedures of DAQSIGNIN that comes with the package.

## Notes

- This manual describes the DX100P style number "S5."
- The contents of this manual are subject to change without prior notice as a result of continuing improvements to the DX100P's performance and functions.
- Every effort has been made in the preparation of this manual to ensure the accuracy of its contents. However, should you have any questions or find any errors, please contact your nearest YOKOGAWA dealer.
- Copying or reproducing all or any part of the contents of this manual without YOKOGAWA's permission is strictly prohibited.
- The TCP/IP software used in this product and the documentation for that TCP/IP software are based in part on BSD Networking Software, Release 1 licensed from The Regents of the University of California.

## Trademarks

- Microsoft, MS-DOS, Windows, and Windows NT are either registered trademarks or trademarks of Microsoft Corporation in the United States and/or other countries.
- Zip is either a registered trademark or a trademark of Iomega Corporation in the United States and/or other countries.
- Adobe, Acrobat, and PostScript are trademarks of Adobe Systems incorporated.
- For purposes of this manual, the TM and ® symbols do not accompany their respective trademark names or registered trademark names.
- Company and product names that are used in this manual are trademarks or registered trademarks of their respective holders.

## Revisions

First edition	December 2001
Second edition	July 2002
Third edition	November 2003
Fourth edition	August 2004

# Safety Precautions

The following general safety precautions must be observed during all phases of operation. If the DX100P is used in a manner not specified in this manual, the protection provided by the DX100P may be impaired. YOKOGAWA Electric Corporation assumes no liability for the customer's failure to comply with these requirements.

This product is a measurement category II (CAT II) instrument.

\* Measurement category II (CAT II)

Applies to measuring circuits connected to low voltage installation, and electrical instruments supplied with power from fixed equipment such as electric switchboards.

The DX100P conforms to IEC safety class I (provided with terminal for protective grounding), Installation Category II, and EN61326-1 (EMC standard), class A (use in a commercial, industrial, or business environment).

Please use this instrument as a measurement category II (CAT II) instrument.

This instrument is for indoor use only.

## Symbols

The following symbols are used on the DX100P.



“Handle with care.” To avoid injury, death of personnel or damage to the instrument, the operator must refer to the explanation in the User's Manual or Service Manual.



Functional ground terminal. Do not use this terminal as a protective ground terminal.



Protective ground terminal.



AC



ON (power)



OFF (power)

## Safety Precautions

**Make sure to comply with the following safety precautions. Failure to comply may result in injury or death (electric shock hazard).**

### WARNING

#### Power Supply

Before connecting the power cord, ensure that the power supply voltage matches the voltage rating for the instrument, and for desktop types, that it is within the maximum rated voltage for the power cord itself.

#### Power Cord and Plug (Desktop Type)

To prevent an electric shock or fire, be sure to use the power cord supplied by YOKOGAWA. The main power plug must be plugged into an outlet with a protective grounding terminal. Do not invalidate protection by using an extension cord without protective grounding.

#### Protective Grounding

Make sure to connect the protective grounding to prevent electric shock before turning ON the power.

#### **Necessity of Protective Grounding**

Never cut off the internal or external protective grounding wire or disconnect the wiring of the protective grounding terminal. Doing so poses a potential shock hazard.

#### **Defect of Protective Grounding**

Do not operate the instrument when the protective grounding or the fuse might be defective. Also, make sure to check them before operation.

#### **Fuse**

To prevent fire, only use a fuse that has a rating (voltage, current, and type) that is specified by the instrument. When replacing a fuse, turn OFF the power switch and unplug the power cord. Never short the fuse holder.

#### **Do Not Operate in Explosive Atmosphere**

Do not operate the instrument in the presence of flammable liquids or vapors. Operation of any electrical instrument in such an environment constitutes a safety hazard.

#### **Do Not Remove Covers**

Some areas inside the instrument have high voltages. Do not remove the cover if the power supply is connected. The cover should be removed by YOKOGAWA's qualified personnel only.

#### **External Connection**

Connect the protective grounding before connecting to the item under measurement or control unit.

#### **Damage to the Protection**

Using the instrument in a manner not specified in this manual can damage the instrument's protection.

---

### **Safety Precautions in Handling the Batteries**

---

#### **WARNING**

- **Abide by the following precautions in handling the batteries. If the batteries are not handled correctly, dangerous conditions may result such as the batteries exploding or leaking.**
  - Insert the batteries according to the polarity indicated on the remote control terminal.
  - Use only the specified batteries.
  - Do not mix different types of batteries.
  - Do not mix new and old batteries.
  - Do not short the positive and negative terminals of the batteries.
  - Do not charge the batteries.
  - If the remote control terminal is not going to be used for an extended time, remove the batteries from the remote control terminal.
  - Dispose the batteries correctly. Do not burn or disassemble the batteries.
  - Do not use batteries that are leaking.
- **If the battery liquid comes in contact with your hands or face, thoroughly wash using water.**

---

#### **Exemption from Responsibility**

- YOKOGAWA makes no warranties regarding the product except those stated in the WARRANTY that is provided separately.
- YOKOGAWA assumes no liability to any party for any loss or damage, direct or indirect, caused by the user or any unpredictable defect of the product.

# Checking the Contents of the Package

Unpack the box and check the contents before operating the DX100P. If some of the contents not correct or missing or if there is physical damage, contact the dealer from which you purchased them.

## DX100P Main Unit

There is a name plate on the back side of the key panel cover. Open the cover and check that the model name and suffix code given on the name plate match those on the order.

### Panel mount type

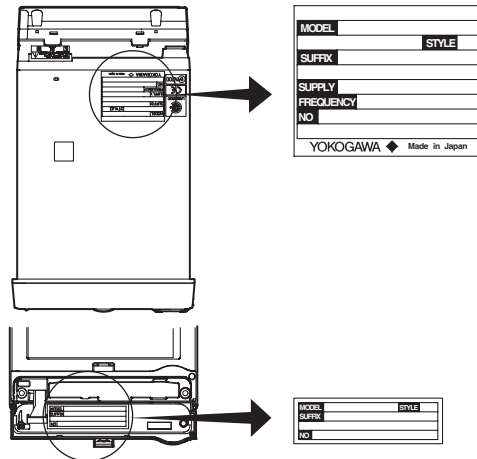

### Desktop type

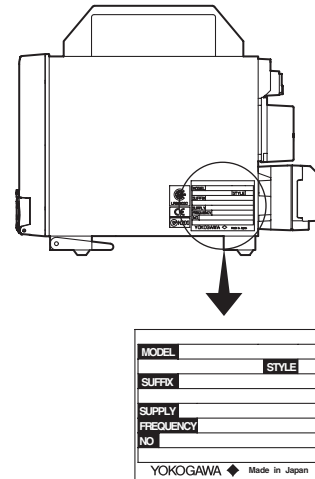

### MODEL

Model code	Suffix code	Optional code	Description
DX102			DAQSTATION DX100P (2 ch)
DX104			DAQSTATION DX100P (4 ch)
DX106			DAQSTATION DX100P (6 ch)
DX112			DAQSTATION DX100P (12 ch)
External storage medium	-2		100 MB Zip disk
	-3		Flash memory card
	-5		250 MB Zip disk
Language	-2		English, deg.F/DST (DAQSIGNIN included)
Options		/AR1	Alarm output relay (2 relays)/remote control <sup>1</sup>
		/AR2	Alarm output relay (4 relays)/remote control <sup>1</sup>
		/A3	Alarm output relay (6 relays) <sup>1</sup>
		/C2	RS-232 interface <sup>2</sup>
		/C3	RS-422-A/485 interface <sup>2</sup>
		/F1	FAIL/memory end output relay <sup>3</sup>
		/H2	Clamped input terminal
		/H5[ ]	Desktop type <sup>4</sup>
		/M1	Computation function (report function included)
		/N1	Cu10, Cu25 RTD input/3 terminal isolated RTD
		/N2	3 terminal isolated RTD <sup>5</sup>
		/P1	24 VDC/AC power supply
		/R1	Remote control
		/TPS2	24 VDC Power supply for transmitter(2 loops) <sup>6</sup>
		/TPS4	24 VDC Power supply for transmitter(4 loops) <sup>7</sup>
	/KB1	Easy Text Entry (with remote control) <sup>8</sup>	
	/KB2	Easy Text Entry (without remote control) <sup>8</sup>	
	/CC1	Calibration Correction	

<sup>1</sup> /AR1, /AR2, and /A3 cannot be specified simultaneously

<sup>2</sup> /C2 and /C3 cannot be specified simultaneously.

<sup>3</sup> If /F1 is specified, /A3 cannot be specified.

<sup>4</sup> /H5: Can only be specified when /P1 is simultaneously specified., /H5D: UL, CSA cable, /H5F: VDE cable, /H5R: SAA cable, /H5J: BS cable

<sup>5</sup> /N2 can only be specified on DX106, and DX112 models.

<sup>6</sup> If /TPS2 is specified, /TPS4, /AR2, /A3 and /F1 cannot be specified.

<sup>7</sup> If /TPS4 is specified, /TPS2, /AR1, /AR2, /A3 and /F1 cannot be specified.

<sup>8</sup> /KB1 and /KB2 cannot be specified simultaneously.

**NO. (Serial No.)**

When contacting the dealer from which you purchased the DX100P, please quote the serial No.

**Standard Accessories**

The following standard accessories are supplied with the DX100P. Make sure that all items are present and undamaged.

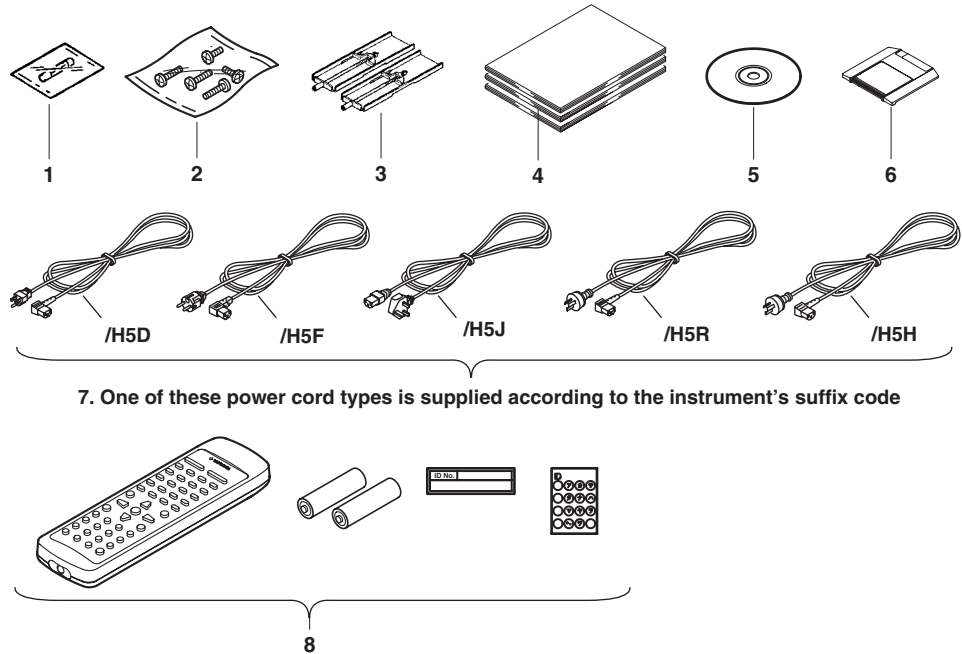

7. One of these power cord types is supplied according to the instrument's suffix code

Number	Part Name	Part Number/Model	Q'ty	Notes
1	Fuse	A1347EF	1	250 V 1 A, time lag (except /P1 model)
		A1352EF	1	250 V 4 A, time lag (/P1 model)
2	Terminal screw		5	M4, for supplementary use
3	Mounting bracket	B9900BX	2	For panel mounting (except /H5[ ] models)
4	User's Manual	IM 04L05A01-01E	1	This manual
	User's Manual	IM 04L05A01-17E	1	DX100P/DX200P Communication Interface
	User's Manual	IM 04L05A01-61E	1	DAQSIGNIN
	User's Manual	IM 04L05A01-02E		DX100P/DX200P Operation Guide
5	Application software (DAQSIGNIN)	DXA150-02	1	Included only when the suffix code for language is "-2." For Windows 98, Windows Me, Windows NT4.0, Windows 2000, Windows XP. Provided on a CD.
6	External storage medium	A1053MP	1	Zip disk (100 MB), included only when the suffix code for external storage medium is "-2."
		A1056MP	1	Zip disk (250 MB), included only when the suffix code for external storage medium is "-5."
		B9968NL	1	Flash memory card (32-MB CF card + adapter, capacity and model of the CF card may vary). Provided only when the suffix code for the external storage medium is "-3."



## Checking the Contents of the Package

Number	Part Name	Part Number/Model	Q'ty	Notes
7	Power cord	A1006WD	1	Provided only when "/H5D" is specified for the optional code. Maximum rated power voltage: 125 V
		A1009WD	1	Provided only when "/H5F" is specified for the optional code. Maximum rated power voltage: 250 V
		A1024WD	1	Provided only when "/H5R" is specified for the optional code. Maximum rated power voltage: 250 V
		A1023WD	1	Provided only when "/H5J" is specified for the optional code. Maximum rated power voltage: 250 V
		A1064WD	1	Provided only when "/H5H" is specified for the power supply code. (complies with the CCC) Maximum rated power voltage: 250 V
8	Remote control	438227	1	Provided only when "/KB1" is terminal specified for the optional code. Alkaline batteries (2 pieces), an ID code entry label, and a character label are included.

### Optional Accessories (Sold Separately)

The following optional accessories are available for purchase separately. If you make an order, make sure that all items are present and undamaged.

For information about ordering accessories, contact the dealer from which you purchased the DX100P.

Number	Part Name	Part Number/Model	Q'ty	Notes
1	Zip disk	A1053MP	1	100 MB
		A1056MP	1	250 MB
2	Flash memory card (CF card + adapter)	B9968NL	1	32-MB card (capacity and model of the CF card may vary, please be careful when ordering)
3	Shunt resistor (for the screw terminal)	4159 20	1	250 $\Omega$ $\pm$ 0.1%
		4159 21	1	100 $\Omega$ $\pm$ 0.1%
		4159 22	1	10 $\Omega$ $\pm$ 0.1%
4	Shunt resistor (for the clamped input terminal)	4389 20	1	250 $\Omega$ $\pm$ 0.1%
		4389 21	1	100 $\Omega$ $\pm$ 0.1%
		4389 22	1	10 $\Omega$ $\pm$ 0.1%
5	Fuse	A1347EF	4	250 V 1 A time lag (except /P1 model)
		A1352EF	4	250 V 4 A, time lag (/P1 model)
6	Mounting bracket	B9900BX	2	
7	Remote control terminal	438227	1	
8	Validation Document for DX100P	438221	1	Electronic file
		438222	1	A4 size paper
		438223	1	Letter size paper

---

# How to Use this Manual

## Structure of the Manual

This user's manual consists of the following sections.

For details on the communication functions and DAQSIGNIN provided with the package, see the respective manuals (IM 04L05A01-17E and IM 04L05A01-61E).

Chapter	Title and Description
1	<b>Overview of Functions</b> Describes the functional overview of the DX100P.
2	<b>Before Using the DX100P</b> Describes the names of each part of the DX100P and how to install and wire the DX100P.
3	<b>Common Operations</b> Describes how to use the storage medium drive, run mode, and common key operations.
4	<b>Settings in the System Mode</b> Describes how to set various items in the system mode.
5	<b>Settings in the Engineering Mode</b> Describes how to set various items in the engineering mode.
6	<b>Basic Operation (Operation Mode)</b> Describes the procedures from logging in and recording measured data to adding approval information to the recorded result.
7	<b>Switching Operation Screens</b> Describes how to use the operation screen such as the trend screen and digital screen. Describes the operations that can be performed using the arrow keys and the DISP/ENTER key on the front panel.
8	<b>Other Operations (Operations Using the FUNC and USER Keys)</b> Describes the operations that can be performed using the FUNC and USER keys.
9	<b>Troubleshooting</b> Describes the error messages and the troubleshooting measures of the DX100P.
10	<b>Maintenance</b> Describes fuse replacement and other information.
11	<b>Specification</b> Describes the specifications of the DX100P.
<b>Appendix</b>	Describes the parameters and initial values of the engineering mode and system mode, data formats of ASCII files, types of data that the DX100P generates, and the time for acquiring display data and event data to the internal memory.
<b>Index</b>	

---

### Note

This manual covers information regarding DX100Ps that have a suffix code for language "-2" (English).

For details on setting the displayed language, see section 4.9.

---

## Conventions Used in This Manual

### Unit

K ..... Denotes “1024.” Example: 768 KB (File capacity)

k ..... Denotes “1000.”

M ..... Denotes “1024K.” Example: 100 MB

B ..... “Bytes.” Example: 100 MB

### Symbols

The following symbols are used in this manual.



*Improper handling or use can lead to injury to the user or damage to the instrument.* This symbol appears on the instrument to indicate that the user must refer to the user’s manual for special instructions. The same symbol appears in the corresponding place in the user’s manual to identify those instructions. In the manual, the symbol is used in conjunction with the word “WARNING” or “CAUTION.”

**WARNING**

Describes precautions that should be observed to prevent injury or death to the user.

**CAUTION**

Describes precautions that should be observed to prevent minor or moderate injury, or damage to the instrument.

### Note

Provides important information for the proper operation of the instrument.

### Reference

⇒ “ ”

Indicates a reference item.

Example: ⇒ “3.6 Entering Numbers and Characters”

### Notation Regarding Procedures

On pages that describe the operating procedures in Chapter 3 through 8, the following symbols are used to distinguish the procedures from their explanations.

[ ]

Represents contents that are displayed on the screen.

Example: [Volt]

#1

Denotes the soft key that is used to make a selection on the engineering and system mode menus.

**Procedure**

Follow the steps indicated with numbers. The procedures are given with the premise that the user is carrying out the steps for the first time. Depending on the operation, not all steps need to be taken.

**Explanation**

This section describes the setting parameters and the limitations regarding the procedures. It does not give a detailed explanation of the function. For detail on the function, see chapter 1.

# Contents

Foreword .....	i
Safety Precautions .....	ii
Checking the Contents of the Package .....	iv
How to Use this Manual .....	vii
<b>Chapter 1 Overview of Functions</b>	
1.1 Overview of the DX100P .....	1-1
1.2 Functions of the Input Section .....	1-2
1.3 Display Function .....	1-6
1.4 Measured/Computed Data Save Function .....	1-20
1.5 Function for Managing Measured/Computed Data .....	1-31
1.6 Alarm Function .....	1-39
1.7 Computation Function and Report Function (/M1 Option) .....	1-43
1.8 FAIL/Memory End Output Function (/F1 option) .....	1-51
1.9 Remote Control Function (/R1 Option) .....	1-53
1.10 Other Functions .....	1-55
<b>Chapter 2 Before Using the DX100P</b>	
2.1 Precautions on the Use of the DX100P .....	2-1
2.2 Names of Parts and Functions .....	2-3
2.3 Installing the DX100P .....	2-6
△ 2.4 Input Signal Wiring .....	2-8
△ 2.5 Alarm Output Wiring (/AR1, /AR2, /A3 Option) .....	2-12
△ 2.6 FAIL/Memory End Wiring (/F1 Option) .....	2-14
△ 2.7 Remote Control Wiring (/R1 Option) .....	2-15
△ 2.8 24 VDC Transmitter Power Supply Wiring (/TPS2, /TPS4, Option) .....	2-16
△ 2.9 Power Supply Wiring .....	2-18
<b>Chapter 3 Common Operations</b>	
3.1 Turning ON/OFF the Power .....	3-1
3.2 Inserting/Removing the External Storage Medium .....	3-2
3.3 Run Mode .....	3-4
3.4 Operations in the Operation Mode .....	3-5
3.5 Setting the Functions (System Mode and Engineering Mode) .....	3-7
3.6 Entering Numbers and Characters .....	3-22
3.7 Using the Remote Control Terminal .....	3-24
<b>Chapter 4 Configuration in the System Mode</b>	
4.1 Setting the Auxiliary Alarm Function .....	4-1
4.2 Setting the A/D Integration Time, Scan Interval, Burnout, Reference Junction Compensation, and Temperature Unit .....	4-3
4.3 Setting the Method of the Display/Event Data Acquisition and Saving .....	4-5
4.4 Registering Users and Setting the Login Function and Electronic Signature Function .....	4-9
4.5 Assigning Actions to the Remote Control Terminals (/R1 Option) .....	4-16
4.6 Setting the Report Function .....	4-17
4.7 Setting the Timer for TLOG Data Acquisition and TLOG Computation .....	4-19
4.8 Setting System Relays (/F1 Option) .....	4-21
4.9 Setting the Auxiliary Functions .....	4-22
4.10 Setting the Time Zone .....	4-24

4.11	Saving/Loading Setup Data .....	4-25
4.12	Loading the Login Information .....	4-28
4.13	Clearing the Data in the Internal Memory and Initializing the Setup Data .....	4-29
4.14	Setting Items That Are Allowed to Be Changed While Data Acquisition Is in Progress .	4-30
4.15	Setting the Time Deviation Limit for Time Correction .....	4-31
4.16	Using the Storage Area of the External Storage Medium Cyclically (FIFO Operation of the Storage Media) .....	4-32

## Chapter 5 Configuration in the Engineering Mode

5.1	Setting Measuring Range .....	5-1
5.2	Setting Alarm .....	5-5
5.3	Setting Tag Names .....	5-7
5.4	Setting Input Filter and Moving Average .....	5-8
5.5	Setting the Alarm Delay Period .....	5-9
5.6	Setting the Display Update Rate and Auto Save Interval .....	5-10
5.7	Setting the File Header and Directory Name .....	5-12
5.8	Assigning an Action to the USER Key .....	5-13
5.9	Setting Groups and Trip Lines .....	5-14
5.10	Setting the Channel Display Colors (Trend, Bar Graph) .....	5-16
5.11	Setting Zone Displays/Partial Expanded Displays (Trend) .....	5-17
5.12	Setting the Scale Division, Bar Graph Base Position (Bar Graph), and Scale Position (Trend) .....	5-19
5.13	Setting the Display Direction, Background Color, Waveform Line Width, Trip Line Width, Grid, Scroll Time, and Scale digit .....	5-24
5.14	Setting the Brightness of the Screen and the Backlight Saver Function .....	5-26
5.15	Setting the Date and Time .....	5-27
5.16	Setting the Message String .....	5-28
5.17	Setting the Batch Information .....	5-29
5.18	Setting Equations, Alarms, and Constants for Computation Channels (/M1 Option) .....	5-30
5.19	Setting the Timer Number and Sum Scale for TLOG Computation (/M1 Option) .....	5-38
5.20	Setting the Rolling Average (/M1 Option) .....	5-39
5.21	Setting the Calibration Correction (/CC1 Option) .....	5-40
5.22	Setting the DST .....	5-42
5.23	Saving/loading the Setup Data .....	5-43
5.24	Saving the Data in the Internal Memory to the External Storage Medium Using Keys ..	5-45

## Chapter 6 Basic Operation

6.1	Login/Logout .....	6-1
6.2	Executing Memory Start/Memory Stop .....	6-4
6.3	Signing Display Data/Event Data .....	6-6

## Chapter 7 Switching Operation Screens (Operations Using the Arrow Keys and DISP/ENTER Key)

7.1	Displaying and Switching Operation Screens .....	7-1
7.2	Using the Trend, Digital, and Bar Graph Screens .....	7-3
7.3	Using the Overview Screen .....	7-8
7.4	Using the Information Screen (Alarm Summary, Alarm ACK Summary, Message Summary, and Memory Summary) .....	7-9
7.5	Using the Historical Trend .....	7-12

**Chapter 8 Other Key Operations**

8.1	Setting the Batch Number, Lot Number, and Comment .....	8-1
8.2	Writing Messages Strings (Trend) .....	8-3
8.3	Storing Measured/Computed Data at Arbitrary Times (Manual Sampling) .....	8-5
8.4	Starting/Stopping Computation, Resetting Computation, Releasing Computation Dropout Display (/M1 Option) .....	8-6
8.5	Saving the Screen Image (Snap Shot) .....	8-8
8.6	Saving the Display Data/Event Data to the External Storage Medium Using Key Operation .....	8-9
8.7	Signing Display/Event Data Files on the External Storage Medium .....	8-10
8.8	Displaying the List of Files and the Free Space on the External Storage Medium .....	8-12
8.9	Displaying the Log Screen/System Screen .....	8-13
8.10	Changing the Password .....	8-16
8.11	Acknowledging Alarms (Alarm ACK) .....	8-17
8.12	Clearing the User Locked Icon .....	8-18

**Chapter 9 Troubleshooting**

9.1	A List of Messages .....	9-1
9.2	Troubleshooting Flow Chart .....	9-13

**Chapter 10 Maintenance**

10.1	Periodic Maintenance .....	10-1
 10.2	Replacing the Fuse .....	10-2
10.3	Calibration .....	10-3
10.4	Recommended Replacement Periods for Worn Parts .....	10-5

**Chapter 11 Specifications**

11.1	Input Specifications .....	11-1
11.2	Display Specifications .....	11-3
11.3	Data Storage Specifications .....	11-5
11.4	Alarm Function Specifications .....	11-7
11.5	Specifications of the Function Used to Manage the Data .....	11-8
11.6	Specifications of Communication Functions .....	11-10
11.7	Specifications of Optional Functions .....	11-11
11.8	General Specifications .....	11-16
11.9	Dimensional Drawings .....	11-21

**Appendix**

Appendix 1	Parameters and Initial Settings .....	App-1
Appendix 2	Data Formats of ASCII Files .....	App-10
Appendix 3	Data Type .....	App-15
Appendix 4	Time for Acquiring Display Data/Event Data to the Internal Memory .....	App-16
Appendix 5	Operation Log Contents and Display .....	App-18
Appendix 6	Style Numbers and Functions .....	App-20

**Index**

<b>1</b>
<b>2</b>
<b>3</b>
<b>4</b>
<b>5</b>
<b>6</b>
<b>7</b>
<b>8</b>
<b>9</b>
<b>10</b>
<b>11</b>
<b>App</b>
<b>Index</b>

## 1.1 Overview of the DX100P

Unlike conventional recorders that record data on charts, the DX100P displays the measured data acquired in the internal memory to a LCD in the form of waveforms, numerical values, and bar graphs. The measured data can also be saved to external storage media such as Zip disks and flash memory cards.

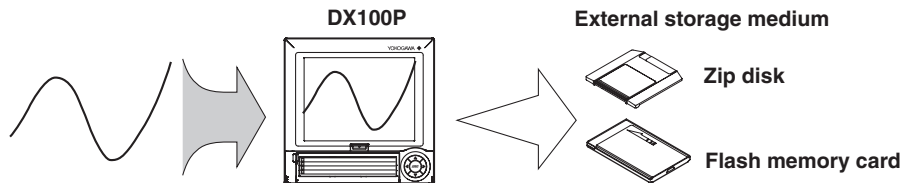

The measured data are managed as follows:

- Only registered users can operate the DX100P.
- The batch number and lot number can be attached to the measured data files.
- Operations and setting changes are recorded in the order of occurrence.
- Up to three users can add approval information to the measured data file.

### Communication Function (See IM 04L05A01-17E)

You can carry out the following types of operations by using the Ethernet communication function.

- Transmit the measured data in units of files to the server on the network (FTP client function).
- Load the measured data on the DX100P, configure and operate the DX100P from a PC on the network (setting/measurement server function).
- Retrieve the files on the external storage medium of the DX100P from a PC on the network (FTP server function).
- Display the screen of the DX100P on a Web browser on a PC (Web server function).
- Transmit e-mail messages to preset recipients when events occur (e-mail transmission function).
- Synchronize to the time on an SNTP server on the network (SNTP client function).
- Transmit time information to clients on the network as an SNTP server (SNTP server function).

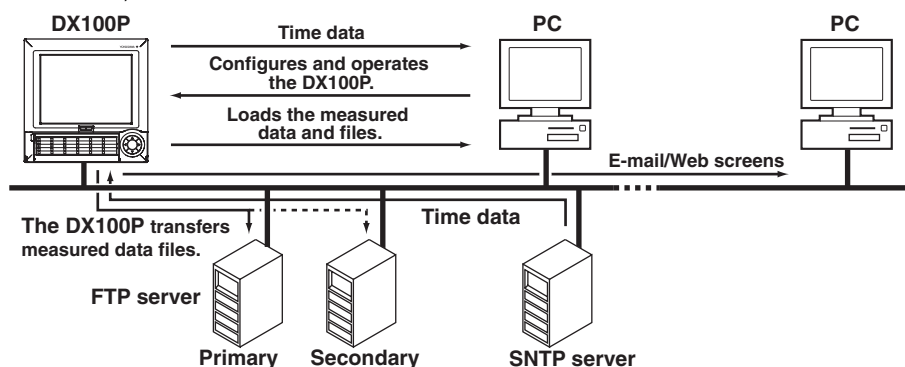

### DAQSIGNIN (See IM 04L05A01-61E)

By using the DAQSIGNIN that comes standard with the DX100P, the following operations are possible.

- Adding approval information to the measured data file
- Converting the measured data to ASCII, Lotus, or Excel formats
- Configuring the setup file for the DX100P
- Receiving the setup data from the DX100P, sending the setup data to the DX100P via the Ethernet interface.

## 1.2 Functions of the Input Section

### Number of Measurement Channels/Scan Interval

The number of measurement channels and scan intervals for different models are listed in the table below. For the procedure related to setting the scan interval, see section 4.2.

Model	Number of Measurement Channels	Scan interval
DX102P	2 channels	125 ms or 250 ms
DX104P	4 channels	125 ms or 250 ms
DX106P	6 channels	1 s or 2 s
DX112P	12 channels	1 s or 2 s

### Input Type and Computation

You can select the input type of a measurement channel from DC voltage, thermocouple, resistance temperature detector (RTD), and digital input (contact signal or voltage signal). For the setting procedure, see section 5.1.

Input type	Description
DC voltage	Measures a DC voltage in the range $\pm 20$ mV to $\pm 50$ V.
DC current	See the explanation below.
Thermocouple (TC)	Measures the temperature corresponding to the appropriate range for R, S, B, K, E, J, T, N, W, L, and U.
Resistance temperature detector (RTD)	Measures the temperature corresponding to the appropriate range for Pt100, JPt100, Cu10*, and CU25.*
Digital input (DI)	Displays the contact input or voltage input signals by correlating them to 0% or 100% of the display range. Contact input: Closed contact is "1." Open contact is "0." Voltage input: Less than 2.4 V is "0." Greater than or equal to 2.4 V is "1."

\* Cu10 and CU25 are optional (/N1).

### DC Current Input

A shunt resistor is attached to the input terminal. The current signal is converted to a voltage signal and measured. The measurable range is the range equivalent to the "DC voltage" range indicated above after converting the current to the voltage signal. A 250  $\Omega$  shunt resistor, for example, is used to convert a 4 to 20 mA to a 1 to 5 V.

Name	Model Code	Specification
Shunt resistors (for screw terminals)	4159 20	250 $\Omega$ $\pm 0.1\%$
	4159 21	100 $\Omega$ $\pm 0.1\%$
	4159 22	10 $\Omega$ $\pm 0.1\%$
Shunt resistors (for clamped terminals)	4389 20	250 $\Omega$ $\pm 0.1\%$
	4389 21	100 $\Omega$ $\pm 0.1\%$
	4389 22	10 $\Omega$ $\pm 0.1\%$

### Input Range and Measurable Range

You can select the "Input range" that is appropriate for the input signal for "DC voltage," "TC," "RTD," and "DI" (for example, R, S, B, K, E, J, T, N, W, L, and U are available input ranges for "TC"). For each "Input range," a measurable range is defined (for example, the measurable range for R of "TC" is "0.0°C to 1760°C"). For details, see section 5.1.

You can specify an arbitrary range within the measurable range as a display span.

Measurable range (Example: TC Type R)

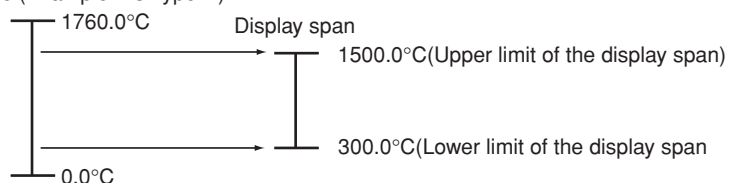



## Computation

You can also perform computation on the input values such as the “difference,” “square root,” and “scaling.” For the setting procedure, see section 5.1.

### Difference Computation

The value obtained by subtracting the measured value of another channel (this channel is called a “reference channel”) from the input value becomes a measured value of the channel.

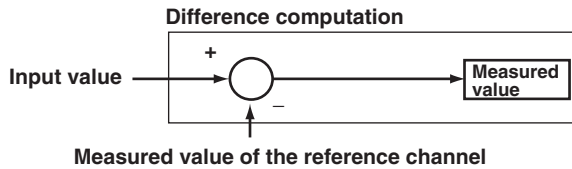

### Note

Even if the input type or the measurement range of the difference computation channel and the reference channel is not the same, the difference computation is performed according to the following rules.

- When the decimal position between the reference channel and the difference computation channel is different, the measured value of the reference channel is adjusted to the decimal position of the measured value of the difference computation channel to make the computation.  
**Example:** When the measured value of the difference computation channel is 10.00 and the measured value of the reference channel is 100.0, the computation result becomes  $10.00 - 100.0 = -90.00$ .
- When the units for the reference channel and the difference computation channel are different, the measured value is not adjusted.  
**Example:** When the measured value of the difference computation channel is 10.00 V and the measured value of the reference channel is 5.00 mV, the computation result becomes  $10.00 \text{ V} - 5.00 \text{ mV} = 5.00 \text{ V}$ .
- When the reference channel is set to [Scale] or [Sqrt], the computation uses the scaled values.
- When the calibration correction (see next page) is applied to the channel, values after correction is used for the computation.

### Scaling

When the input type is set to “DC voltage,” “thermocouple,” “RTD,” or “digital input,” the input value is converted to a value in the appropriate unit and the converted value becomes a measured value of the channel.

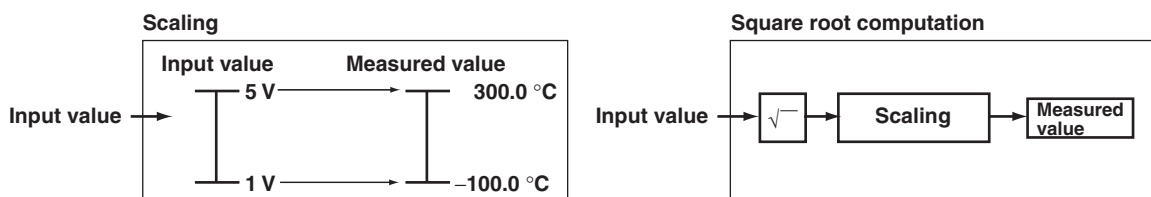

### Square Root

When the input type is set to “DC voltage,” the square root of the input value is computed. The computed result is scaled to a value in the appropriate unit and the scaled value becomes a measured value of the channel.

### Note

- The DX100P uses the following square-root computation:

$$F_x = (F_{max} - F_{min}) \sqrt{\frac{V_x - V_{min}}{V_{max} - V_{min}}} + F_{min}$$

- Vmin: Lower limit of span
- Vmax: Upper limit of span
- Fmin: Lower limit of scale
- Fmax: Upper limit of scale
- Vx: Input voltage
- Fx: Scaling value
- When the value inside the square root is negative, the measured value is indicated as when  $F_{min} < F_{max}$ : “-\*\*\*\*\*,” or when  $F_{min} > F_{max}$ : “+\*\*\*\*\*”.

**Calibration Correction (/CC1 Option)**

Corrects the measured value of each channel using ten-segment linearizer approximation and makes the resultant value the measured value of the channel. You can set arbitrary true values (measured values after correction) for up to 16 points of arbitrary measured values. Linear approximation is used between two segment points. For the setting procedure, see section 5.21.

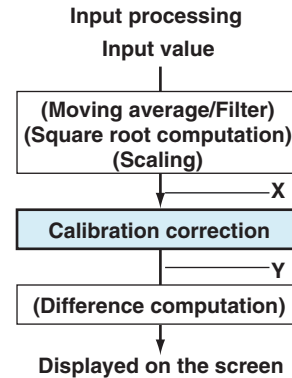
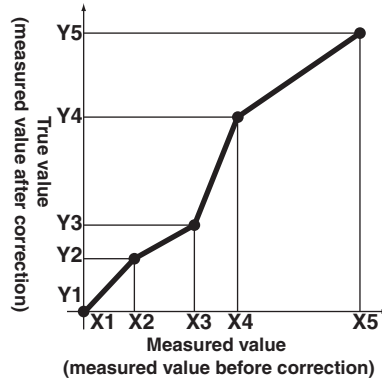

**Burnout**

When measuring temperature using a thermocouple and the thermocouple burns out, you can specify the measurement result to be set to positive over range\* or negative over range.\* Burnout can be set on each measurement channel. For the setting procedure, see section 4.2.

- \* Positive over range is a condition in which the input signal is over the upper limit of the measurable range. The measured value is indicated as “+\*\*\*\*\*.”
- Negative over range is a condition in which the input signal is below the lower limit of the measurable range. The measured value is indicated as “-\*\*\*\*\*.”

**Note**

- When the alarm is set to detect positive or negative over range, the occurrence of burnout of thermocouple can be displayed as an alarm.
- Turn the burnout function OFF when connecting the input wires in parallel with other devices.

**Reference Junction Compensation (RJC)**

When measuring the temperature using a thermocouple, the reference junction compensation can be used. You can select whether to use the reference junction compensation provided by the DX100P or external reference junction compensation. If you are using external reference junction compensation, you will also set the reference voltage. For the setting procedure, see section 4.2.

**Note**

- When using the reference junction compensation of the DX100P, see “Precautions to be taken while wiring” in section 2.4, “Input Signal Wiring.”
- When using the external reference junction compensation, set an appropriate reference junction compensation voltage. As in the example in the following figure, if the reference junction temperature for the external reference junction compensation is  $T_0$  °C, set the thermoelectromotive force of the 0 °C reference for  $T_0$  °C as the reference junction compensation voltage.

**An example of External reference junction compensation**

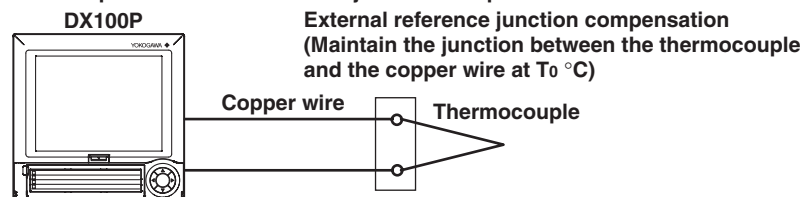

## Filter and Moving Average

The filter and moving average are used to suppress the effects of noise that is riding on the signal. Filtering is provided on the DX102P and DX104P. Moving average is provided on the DX106P and DX112P. The filter or moving average can be set on each channel. For the setting procedure, see section 5.4.

### Filter Function (DX102P and DX104P)

Suppresses the effects of noise above the frequency determined by the specified time constant. The time constant can be set to 2 s, 5 s, or 10 s.

#### Effects of using filter(Output response for a step input)

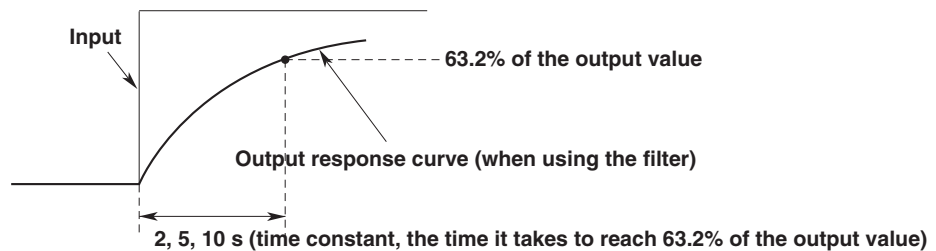

### Moving Average (DX106P and DX112P)

The input signal of the measurement channel is set to the averaged value of the **m** most current data points (the number of moving-averaged data points) acquired at the scan interval. The number of moving-averaged data points can be set in the range 2 to 16. The figure below shows an example indicating the operation of the buffer for the moving average computation when the number of moving-averaged data points is set to "5."

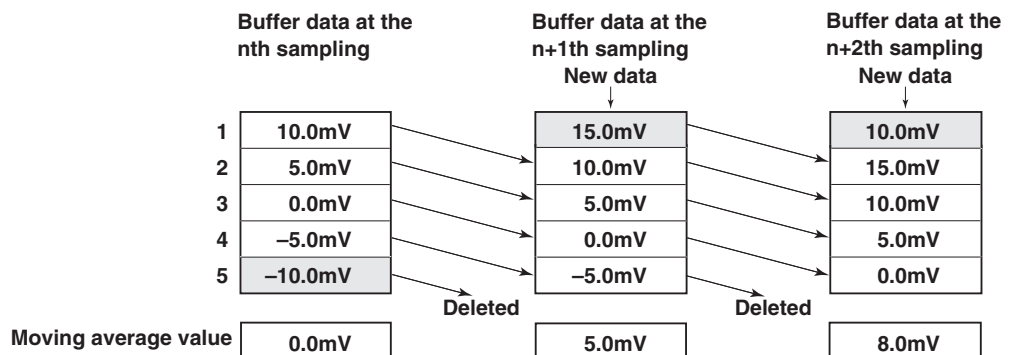

## Integration Time of the A/D Converter

The DX100P uses an A/D converter to convert the sampled analog signal to a digital signal. By setting the integration time to match the time period corresponding to one cycle of the power supply or an integer multiple of one cycle, the power supply frequency noise can be effectively eliminated.

The integration time of the A/D converter is selected from the table below.

Model	Integration Time of the A/D Converter
DX102P/DX104P	Select 16.7 ms (60 Hz), 20 ms (50 Hz), or Auto
DX106P/DX112P	Select 16.7 ms (60 Hz), 20 ms (50 Hz), 100 ms, or Auto

- If "Auto" is selected, the DX100P will automatically detect the power supply frequency and select 16.7 ms or 20 ms. However, the integration time is fixed to 20 ms on /P1 models that use the 24 VDC power supply.
- Because 100 ms is an integer multiple of 16.7 ms and 20 ms, this setting can be used to eliminate the power frequency noise for either frequency, 50 Hz or 60 Hz. 100 ms is available on the DX106P and DX112P. However, when the integration time is 100 ms, the scan interval is fixed to 2 s.

For the setting procedure, see section 4.2.

# 1.3 Display Function

## Common Items Related to the Display

### 5.5" TFT Color LCD and the Screen Configuration

The DX100P has a 10.4" TFT color LCD (240-by-320 dot resolution). The screen consists of the status display section and the data display section.

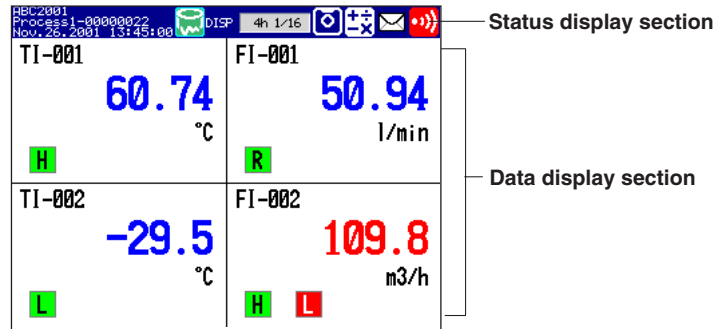

- **Status Display Section**

Displays the displayed screen name, date and time or batch number/lot number, user name, internal memory/external storage medium usage condition, alarm condition, and computation condition (/M1 option). For details, see page 1-18.

- **Data Display Section**

Displays measured/computed data\* using numerical values, waveforms, bar graphs, and so on. Shows the setup screen when setting functions.

\* The measured values of measurement channels and the computed values of computation channels (/M1 option) of the DX100P including the time information when they are acquired are called "measured data" and "computed data," respectively.

### Group Display

The data displayed on the trend, digital, and bar graph screens are the data of measurement or computation channels that are assigned to the group. Up to 6 channels can be assigned to a single group. Up to 6 groups can be registered. The groups are common to the trend, digital, and bar graph screens. For the procedure used to assign channels to groups, see section 5.9.

On the trend, digital, and bar graph screens, the displayed groups can be automatically switched at 5 s, 10 s, 20 s, 30 s, or 1 min intervals. For the setting procedure, see section 5.13.

### Channel Number or Tag Name Display

The channels can be displayed as channel number or tags. The setting applies to all channels. For the setting procedure, see sections 4.9 and 5.3.

### Alarm Indication

Alarms are checked at all times and displayed on the relevant screens using alarm type symbols. For details related to setting alarms, see sections 4.1, 5.2, and 5.18.

Name	Symbol	Name	Symbol
Upper limit alarm	H	Upper limit on rate-of-change alarm	R
Lower limit alarm	L	Lower limit on rate-of-change alarm	r
Difference upper limit alarm	h	Delay upper limit alarm	T
Difference lower limit alarm	l	Delay lower limit alarm	t

### Trend Screen

Displays the waveform of the measured and computed data. The direction of the waveform display can be set to horizontal or vertical. For details related to the display method, see section 7.2.

#### Trend (Vertical)

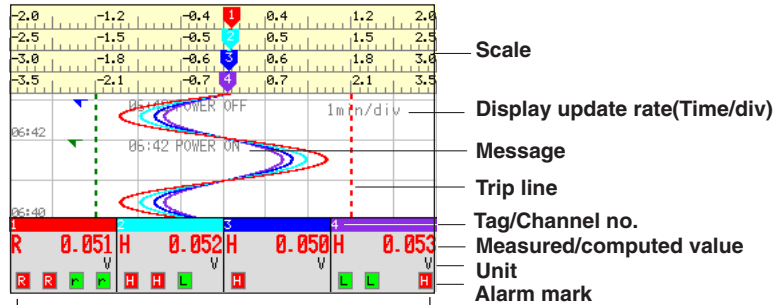

#### Numerical display section

#### Trend (Vertical, All channel display)

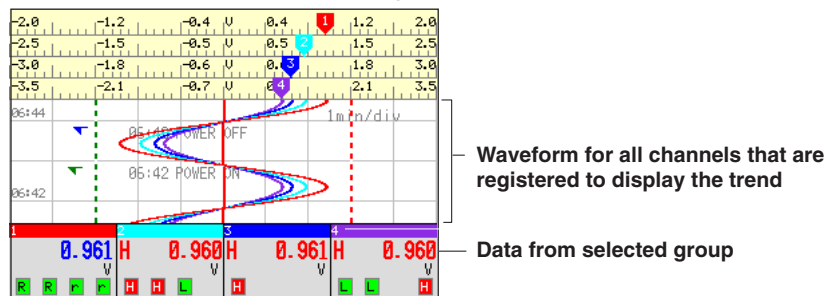

#### Trend Display (Horizontal, Type 1)

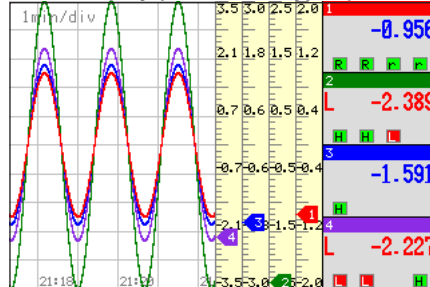

#### Trend Display (Horizontal, Type 2)

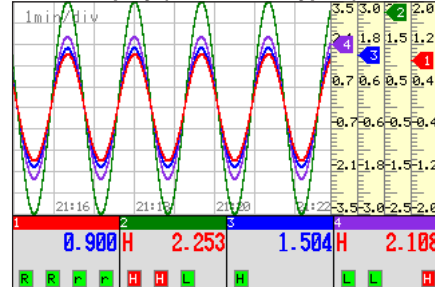

#### Updating the Waveform and Updating the Numerical Display

One division along the time axis consists of 30 dots on the LCD. The displayed waveform is updated at an interval corresponding to one dot. This interval is determined by the time period corresponding to one division (referred to as the **display update rate**). For the procedure related to setting the display update rate, see section 5.6. The relationship between the display update rate and the speed of movement of waveforms is as follows:

Display Update Rate (/div)	15 s <sup>*1</sup>	30 s <sup>*1</sup>	1 min	2 min	5 min	10 min	15 min	20 min	30 min	1 h	2 h	4 h	10 h
Interval corresponding to one dot (s)	0.5	1	2	4	10	20	30	40	60	120	240	480	1200
Speed of movement of waveforms <sup>*2</sup> (approximate value, mm/h)	2376	1188	594	297	119	59	40	30	20	10	5	2.5	1.0

\*1 for DX102P and DX104P only

\*2 Speed of movement of waveforms = 30 (dots) × 0.33 mm (dot pitch) × 60 min / [display update rate (min)]

Measured/computed values are updated every second. However, when the scan interval on the DX106P/DX112P is 2 s, the update rate is also 2 s.

## 1.3 Display Function

### Displayed Data

The data displayed on the screen are a maximum and minimum values of the data that are sampled at the scan interval, within the time period corresponding to one dot.

#### Displayed data of the waveform (when the display update rate is set to one minute)

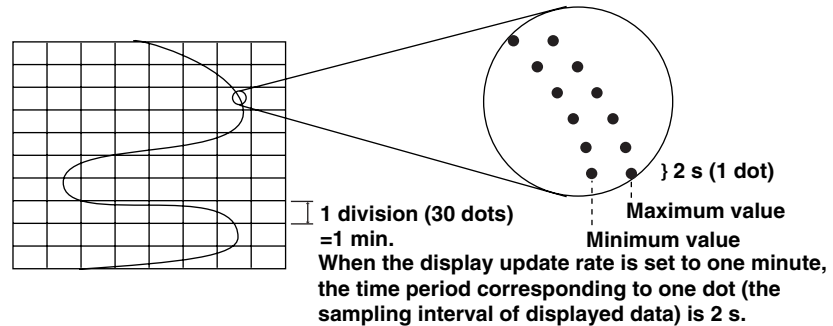

### Displayed Information

The following Information can be displayed.

Information	Description
All channel display	Waveforms of all channels that were set to display the trend are displayed on one trend screen. ⇒“Sections 4.3 and 7.2”
Message writing	Specified messages can be written at arbitrary points in time. Messages are written to the internal memory and displayed on the waveform display section. See the explanation on next page. ⇒“Sections 5.16 and 8.2”
Display direction of waveforms	The waveform can be displayed vertically or horizontally. ⇒“Section 5.13”
Displayed color of waveforms	The displayed color of waveforms can be specified for each channel. The color also applies to the bar graph. ⇒“Section 5.10”
Thickness of waveform lines	You can select from 1, 2, or 3 dots. The specified thickness of waveform lines applies to all channels. ⇒“Section 5.13”
Trip line display	Displays a line to indicate a particular value of interest (trip line) for each group. You can select the thickness of the displayed line from 1, 2, or 3 dots. Up to four trip lines can be displayed on a single group. ⇒“Sections 5.9 and 5.13”
Scale display	A scale appropriate for the measured item can be displayed for each channel. The number of divisions of the scale created by the main scale marks can be set to a value in the range 4 to 12 div (also applies to the bar graph). Medium and small scale marks are displayed in between the main scale marks. ⇒“Section 5.12” You can select whether or not to display the scale for each channel.
Grid	The specified number of lines are displayed on the waveform display area. ⇒“Section 5.13”
Turn ON/OFF the numerical display section	The numerical display section can be turned ON or OFF. If the numerical display section is turned OFF, the display shows only the waveform and the scale. ⇒“Section 7.2”
Zone display	The waveform of each channel is displayed in its display range (zone). The waveforms are easier to view, because they do not overlap. See the explanation of the zone display below. ⇒“Section 5.11”
Partial expanded display	You can expand the important section of the display range. See the explanation of the partial expanded display below. ⇒“Sections 4.9 and 5.11”

**Messages**

There are the following two types of messages.

• **Preset Messages**

Messages are set beforehand and recalled and written when necessary.  
 Number of messages available: 56 messages (8 messages x 7 groups)\*

\* The eight messages of group 7 can be assigned to the USER key and the remote control function (/R1 option) to be written.

• **Free Messages**

Messages are entered when you need to enter them.

**Preset messages**

Group 1		2	7
1	Start		
2	Material 1		
3			
4			
5			
6			
7			
8			
7			
8			

**Trend screen**

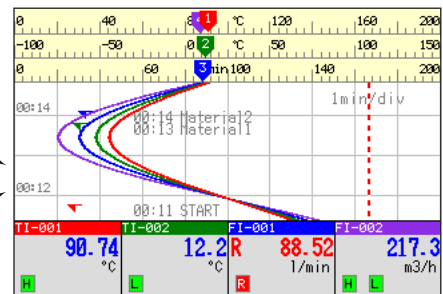

**Free messages**

Set the message when you wish to write it.

**Explanation Regarding the Zone Display**

The display range (zone) can be set for each channel. In the example shown in the figure below, channel 1 is displayed in the zone 0 to 30%, channel 2 in the zone 30 to 60%, and channel 3 in the zone 60 to 100%.

**Normal display**

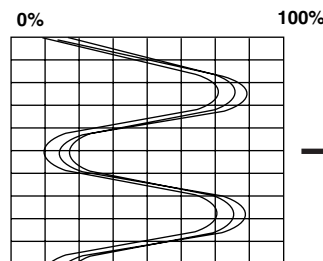

**Zone display**

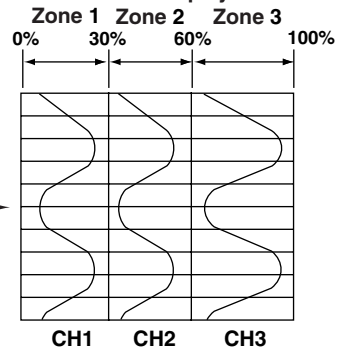

**Explanation Regarding the Partial Expanded Display**

By compressing a section of the display scale of the waveform, the remaining section of is expanded. You specify a value on the display scale (boundary value) to be moved to another position on the display scale (boundary value displacement position). In the example shown below, 0 V (boundary value) is moved to the 30% position of the display scale (boundary value displacement position). The section below the boundary represents -6 V to 0 V and the section above the boundary represents 0 V to 6 V.

**Normal Display**

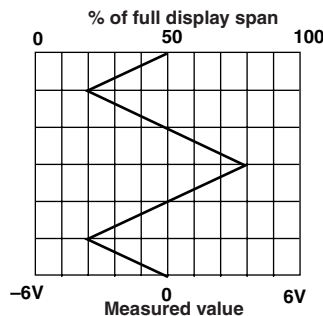

**Partial Expanded Display**

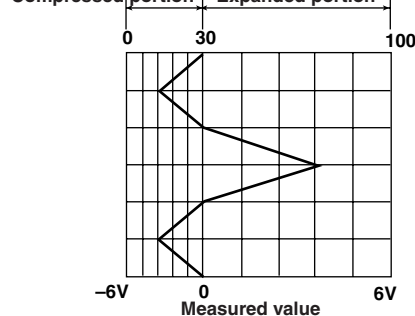

### 1.3 Display Function

#### Digital Screen

The measured/computed data are displayed using numerical values in large size. See section 7.2.

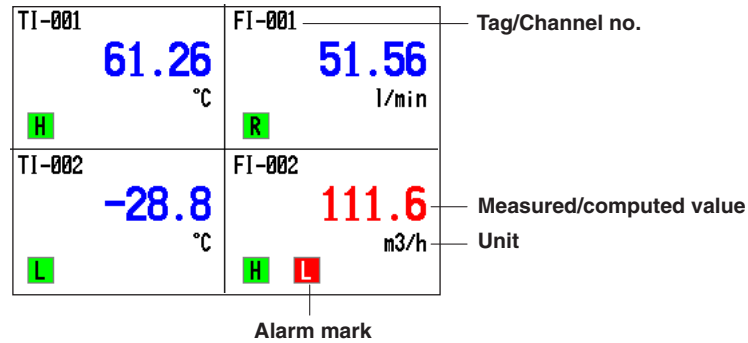

#### Updating of the Numerical Display

Measured/computed values are updated every second. However, when the scan interval on the DX106P/DX112P is 2 s, the update rate is also 2 s.

#### Note

- Numerical Display of Measurement Channels (Common to Trend, Digital, and Bar Graph Displays)**

When the measured values of measurement channels are over range (see below), the measured values are indicated as “+\*\*\*\*\*” or “-\*\*\*\*\*.” Otherwise, the numerical values are displayed.

#### Over Range of Measurement Channels

- For DC voltage input, over range occurs when the measured value of the measurement channel exceeds  $\pm 5\%$  of the measurable range. For example, the measurable range when the measurement range is 2 V is  $-2.000$  to  $2.000$  V. If the measured value exceeds  $2.200$  V, + over range occurs; if the measured value falls below  $-2.200$  V, - over range occurs.
- For thermocouple or RTD input, over range occurs when the measured value exceeds approximately  $\pm 10^\circ\text{C}$  of the measurable range. For example, the measurable range when the measurement range is R is  $0.0$  to  $1760.0^\circ\text{C}$ . If the measured value exceeds approximately  $1770.0^\circ\text{C}$ , + over range occurs; if the measured value falls below approximately  $-10.0^\circ\text{C}$ , - over range occurs.
- Numerical display of computation channels (common to trend, digital, and bar graph displays)**

See section 1.7.

#### Alarm Indication

The indications of preset alarm marks vary depending on the hold/non-hold setting of alarm indication (see section 1.6) as follows. The indication patterns are common to trend, digital and bar graph.

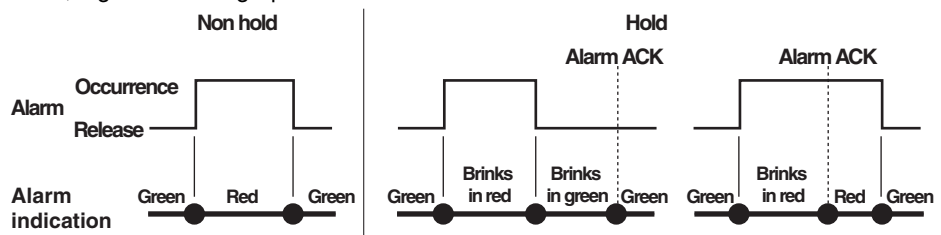



## Bar graph Screen

The measured/computed data are displayed using bar graphs. See section 7.2.

### Bar Graph (Horizontal)

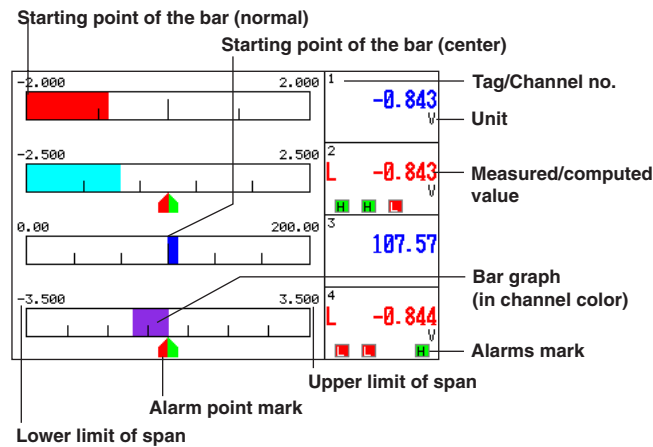

### Bar Graph (Vertical)

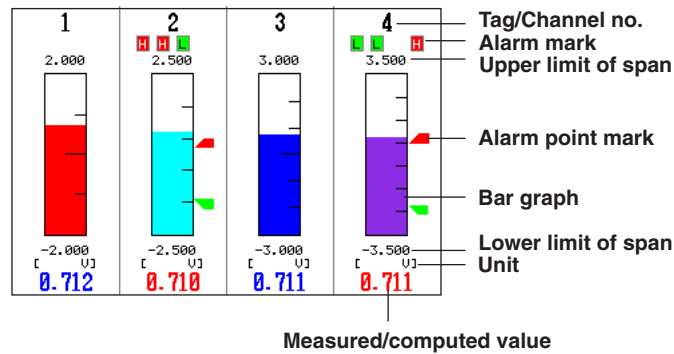

### Updating of the Bar Graph and the Numerical Display

Measured/computed values are updated every second. However, when the scan interval on the DX106P/DX112P is 2 s, the update rate is also 2 s.

### Displayed Information

The following Information can be displayed.

Information	Description
Display direction	The bar graphs can be displayed horizontally or vertically. ⇒ "Section 5.13"
Base position	When the bar graph is displayed horizontally, the starting point of the bar (base position) can be set to the minimum edge of the measurement scale or to the center position. ⇒ "Section 5.12"
Displayed color	The displayed color of the channels are common with the trend. ⇒ "Section 5.10"
Scale display	The number of divisions of the scale can be set to a value in the range 4 to 12 (common with the trend). ⇒ "Section 5.12"

### 1.3 Display Function

#### Overview Screen

Displays a list of measured/computed values and alarm conditions of all measurement/computation channels.

- You can move the cursor to select a channel and display the trend or bar graph of the group containing the selected channel.
- Alarm ACK operation can be performed on each alarm. Alarm ACK operation refers to the operation performed to clear the alarm display and relay output (option).

For details on the operations on the overview screen, see section 7.3.

Tag/Channel no.	1	7	31	37	
Cursor	2	8	32	38	
Alarms occurring	3	9	33	39	
Measured/computed value	4	10	34	40	
	5	11	35	41	
	6	12	36	42	

The area corresponding to a channel on which an alarm is occurring is displayed in red.

#### Updating of the Numerical Display

Measured/computed values are updated every second. However, when the scan interval on the DX106P/DX112P is 2 s, the update rate is also 2 s.

#### Alarm Indication

The display in the channel display area and channel No./tag name when an alarm occurs on any of the channels varies depending on the hold/non-hold setting of alarm indication (see section 1.6) as follows.

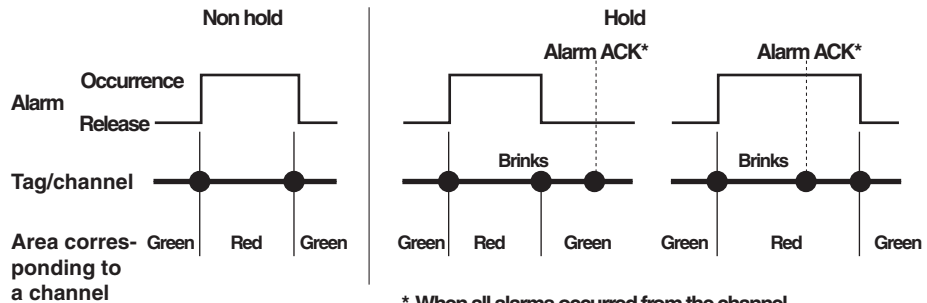

\* When all alarms occurred from the channel are acknowledged by the alarm ACK operations

#### Alarm Summary

A list of the most recent alarms can be displayed.

- Up to 240 incidents can be stored to the internal memory. When this number is exceeded, data are overwritten from the oldest data.
- By scrolling the screen using arrow keys, the alarms stored in the internal memory can be displayed.
- By selecting an alarm from the list using arrow keys, the historical trend of the display data or event data containing the alarm can be recalled. For a description on the historical trend display, see "Historical Trend" in this section.

For the operating procedure, see section 7.4.

Number of the alarm information displayed at the bottom of the screen  
 Number of the alarm information in the internal memory  
 Tag/Channel no.  
 Alarm No. (1, 2, 3, 4) /Type (H, L, h, l, R, r, T, t)  
 Date & Time (alarm occurred)  
 Date & Time (alarm was released)

(020-030)	Channel	Type	Alarm IN Time	Alarm OUT Time
●	FI-002	2L	Nov.26 16:27:44	Nov.26 16:22:58
●	FI-002	2L	Nov.26 16:22:07	Nov.26 16:17:28
●	FI-002	2L	Nov.26 16:18:29	Nov.26 16:11:43
●	FI-002	2L	Nov.26 16:05:14	Nov.26 16:06:05

Mark (indicates the alarm status)  
 Cursor (selects the alarm information)

Historical trend of the data containing the selected alarm information

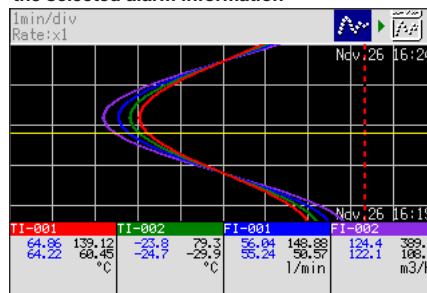

**Alarm Mark Indication**

The mark indication varies depending on the hold/non-hold setting of alarm indication (see section 1.6) as follows.

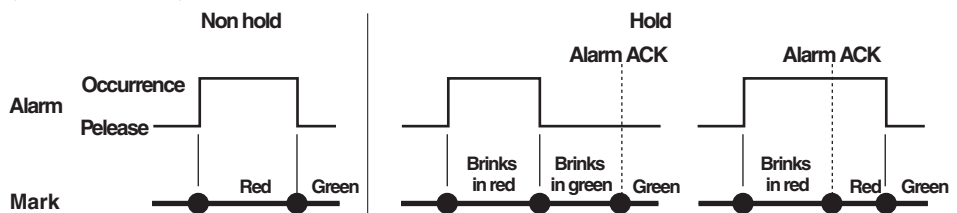

**Alarm ACK Summary**

A record of alarm ACK operations can be displayed.

- Up to 240 incidents can be stored to the internal memory. When this number is exceeded, data are overwritten from the oldest data.
- By scrolling the screen using arrow keys, the alarms ACKs stored in the internal memory can be displayed.

For the operating procedure, see section 7.4.

Number of Alarm ACK information displayed at the bottom of the screen

Number of Alarm ACK information in the internal memory  
 Alarm No. (1, 2, 3, 4) /Type (H, L, h, l, R, r, T, t)  
 Alarm ACK time  
 User name

(016-016)	Channel	Type	ACK Time	User Name
●	TI-001	1H	Nov.16 09:09:49	ABC2001
●	FI-002	1H	Nov.16 09:09:23	ABC2001
●	FI-001	1R	Nov.16 09:09:29	ABC2001
●	FI-001	1R	Nov.16 09:09:29	ABC2001
●	FI-001	1R	Nov.16 09:09:29	ABC2001

Tag/Channel no.  
 Mark (indicates the alarm status)

(Space): Key operation  
 [R]: Operation via remote control (/R1 option)  
 [M]: Operation via Ethernet communications  
 [S]: Operation via serial communications (/C2, /C3 option)

### 1.3 Display Function

#### Message Summary

The messages and the times when they were entered are displayed in a list.

- Up to 250 messages can be stored to the internal memory. When this number is exceeded, data are overwritten from the oldest data.
- By scrolling the screen using arrow keys, the messages stored in the internal memory can be displayed.
- By selecting a message from the list using arrow keys, the historical trend of the display data or event data containing the message can be recalled. For a description on the historical trend, see "Historical Trend" in this section.

For the operating procedure, see section 7.4.

Number of the message displayed at the bottom of the screen

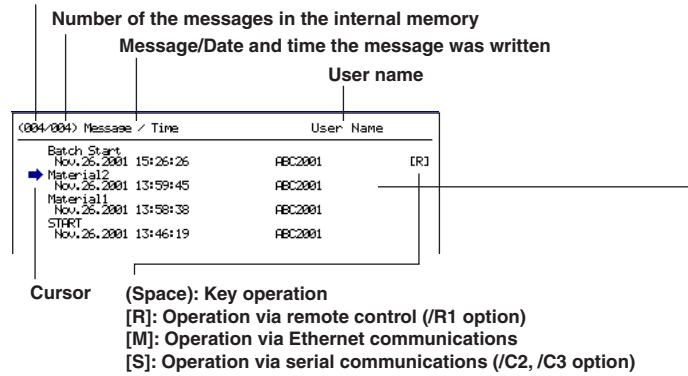

Historical trend of the data containing the selected message

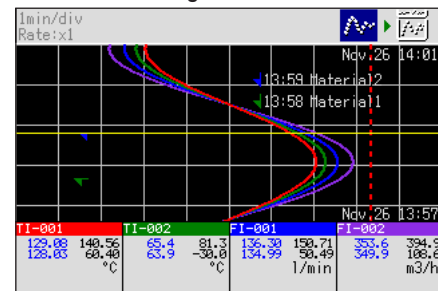

### Memory Summary

The information pertaining to the display data and event data in the internal memory is displayed.

- By selecting the display data\* or event data\* using the arrow keys, the historical trend display can be recalled. For a description on the historical trend, see “Historical Trend” in this section.
  - \* For a description on the display data and event data, see section 1.4.
- The number of manual sampled data, TLOG data (/M1 option), and report data (/M1 option) residing in the internal memory are displayed.
- For models that have the alarm output relays (option), the ON/OFF state of the relays are also listed.

For the operating procedure, see section 7.4.

#### Report data

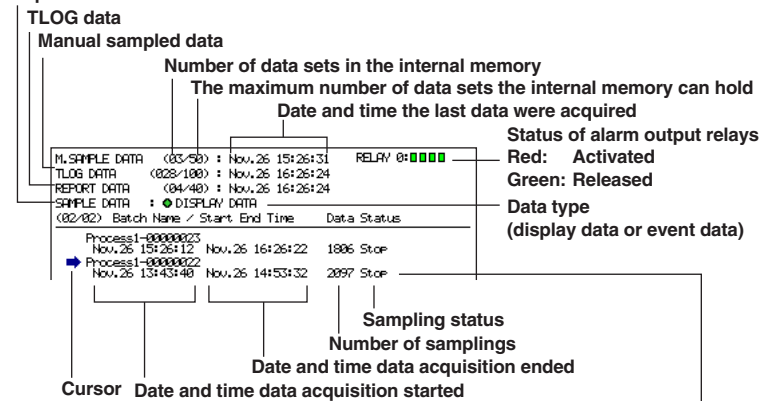

#### Historical trend of the selected data

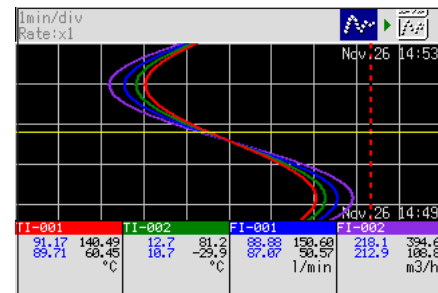

### Report Data (/M1 option)

Report data residing in the internal memory can be displayed.

For details related to the report data, see section 1.7. For the operating procedure, see section 7.4.

The index number of the report data currently displayed

The number of report data in the internal memory

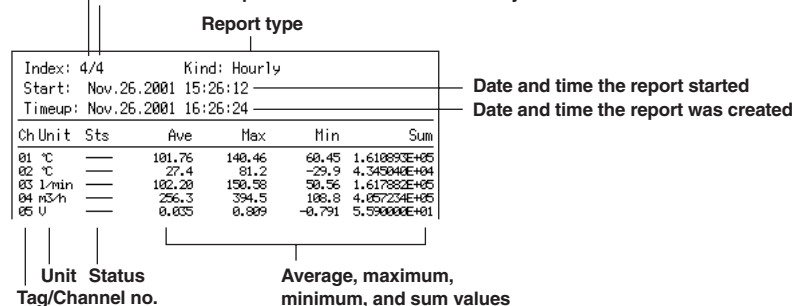

### Historical Trend

The waveform of the past display data\* and event data\* in the internal memory can be displayed. This function is called “Historical trend.”

\*1 For details of display data and event data, see section 1.4.

#### Methods Used to Display the Historical Trend

The following four methods are available in displaying the historical trend of the display data or event data in the internal memory:

- Display from the alarm summary. For the operating procedure, see section 7.4.
- Display from the message summary. For the operating procedure, see section 7.4.
- Display from the memory summary. For the operating procedure, see section 7.4.
- Recall from the screen menu. For the operating procedure, see section 7.5.

#### Information Displayed on the Historical Trend

Alarms and scales are not displayed on the historical trend display.

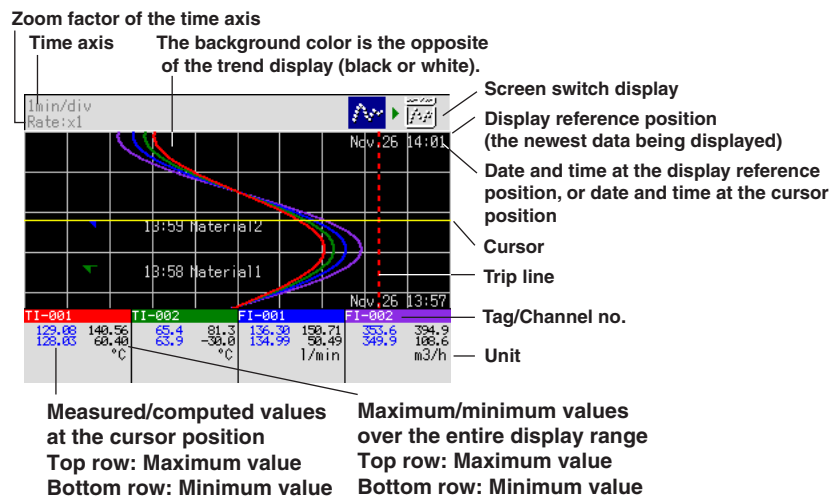

#### Operation on the Historical Trend

The following operations can be carried out. For the operating procedure, see section 7.5.

- Measured/computed values and the date and time at an arbitrary position can be read by moving the cursor using the arrow keys.
- The waveform can be scrolled along the time axis using the the arrow keys.
- The time axis can be expanded or reduced.
- The information of the data being displayed on the historical trend can be displayed.
- You can display all the data points of the file displayed on the historical trend display in a section of the screen (all data display) and specify the range of data to be displayed on the historical trend using a frame.

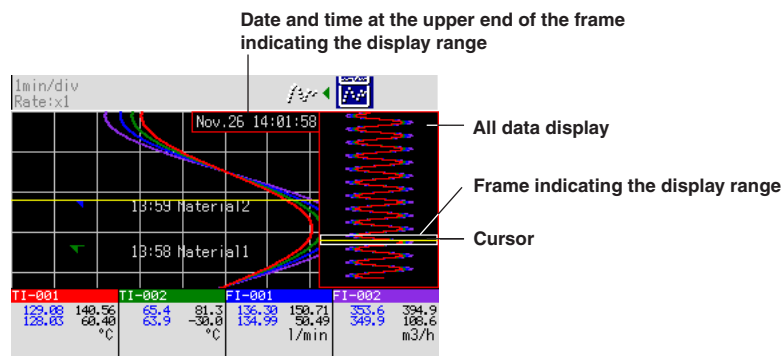

## Sign Record Screen

Loads the display/event data file saved on the external storage medium and displays the waveform.

### Viewing Method

- If “Batch Stop sign record” is specified, the sign record screen appears when Memory Stop is executed (see section 6.2).
- The sign record screen appears through the “data load” operation using the FUNC key (see section 8.7).

### Information Displayed on the Sign Record Screen

See the explanation in the “Historical Trend” section.

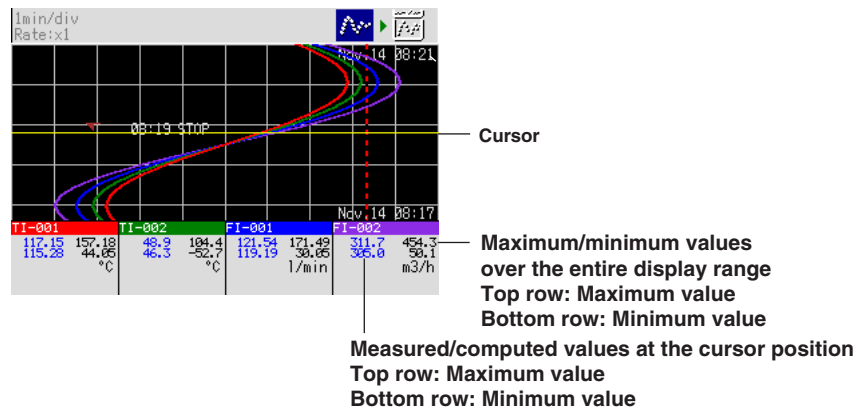

### Operation on the Sign Record Screen

The following operations can be carried out. For the operating procedure, see section 6.3.

- **Sign (add approval information to) the display data files or the event data files on the external storage medium.**
- **View the operation log, alarm summary, alarm ACK summary, and message summary and confirm the information.**
- **Select an alarm on the alarm summary and display the waveform around the point where the alarm occurred.**
- **Select a message on the message summary and display the waveform around the point when the message was written.**

The following functions are the same as those for the historical trend.

- Measured/computed values and the date and time at an arbitrary position can be read by moving the cursor using the arrow keys.
- The waveform can be scrolled along the time axis using the cursor keys.
- The time axis can be expanded or reduced.
- The file information of the loaded file can be displayed.
- You can display all the data points of the loaded file in a section of the screen (all data display) and specify the range of data to be displayed on the historical trend using a frame.

**Status Display Section**

The following information is displayed in the status display section during operation mode or engineering mode.

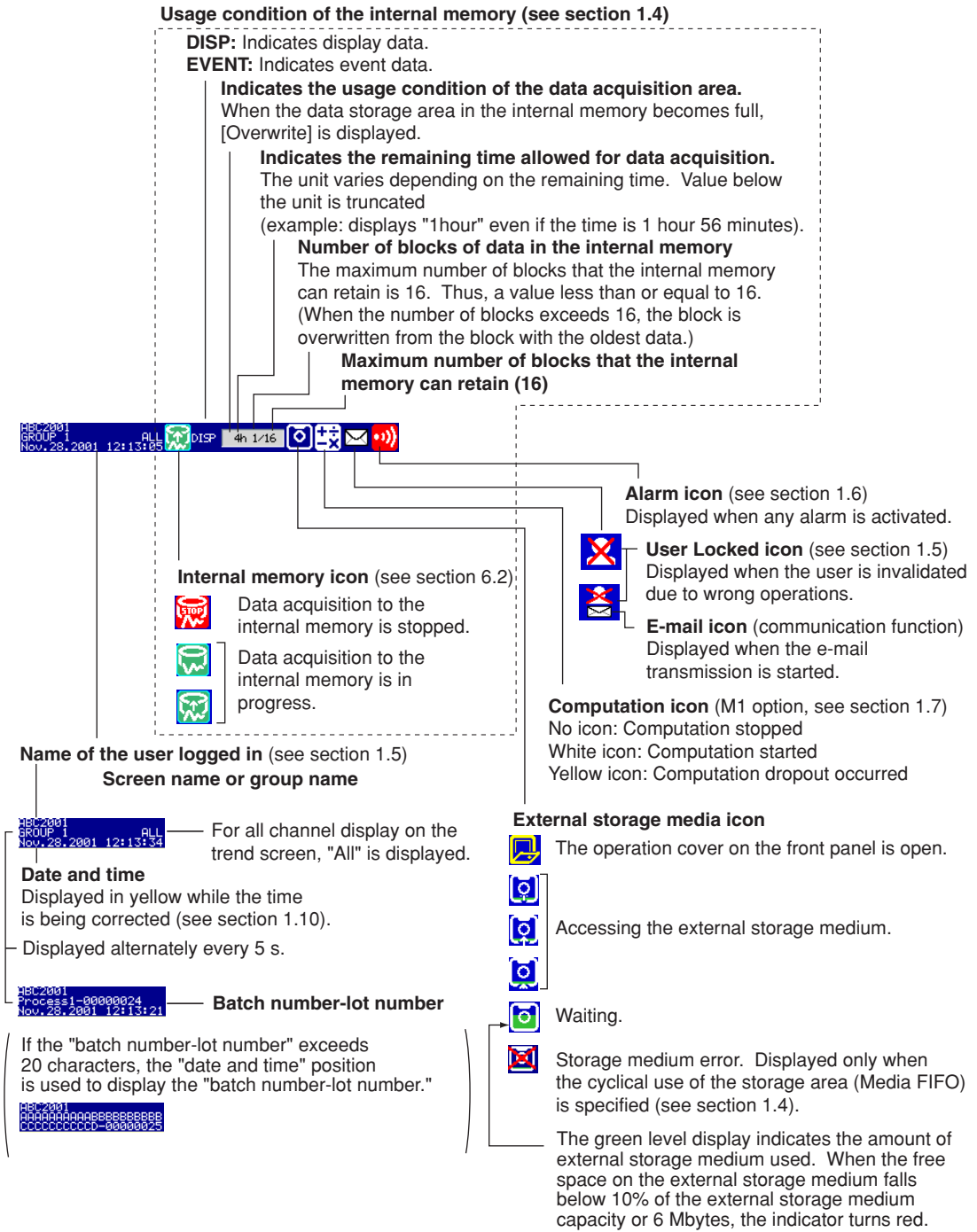



## Setting the Display Conditions of the LCD

The display conditions of the LCD can be configured.

LCD Environment	Setting
Background color of the operation screen	The background color of the screen can be set to white or black. The initial setting is "white." For the procedure, see section 5.13.
LCD brightness	The brightness of the LCD can be set between eight levels. The initial setting is "4." For the procedure, see section 5.14.
Backlight saver	The lifetime of the LCD backlight can be extended by automatically dimming the light when there is no key operation for a certain amount of time. The screen returns to the original brightness with a key operation or an alarm occurrence. The initial setting is set so that the backlight saver is disabled. For the procedure, see section 5.14.

# 1.4 Measured/Computed Data Save Function

## Data Type

The types of measured/computed data that can be saved to the external storage medium are as follows.

Type	Description
Display data	Waveform data displayed on the trend display. The data is managed using <b>batch/lot numbers</b> or a <b>file name Mddhhmma.DBD</b> . Data format: BINARY (Undisclosed)
Event data	Measured/computed data (instantaneous value) that have been continuously sampled at a specified sampling interval. The data is managed using <b>batch/lot numbers</b> or a <b>file name Mddhhmma.DBE</b> . Data format: BINARY (Undisclosed)
Manual sampled data	Measured/computed data (instantaneous value) at an arbitrary point. <b>File name: Mddhhmma.DMN</b> Data format: ASCII
TLOG data (/M1 Option)	Measured/computed data (instantaneous value) at intervals set using a timer. <b>File name: Mddhhmma.DTG</b> Data format: BINARY (Undisclosed)
Report data (/M1 Option)	Hourly, daily, weekly, and monthly report data. <b>File name: Mddhhmma.DHR (hourly), Mddhhmma.DDR (daily), Mddhhmma.DWR (weekly), Mddhhmma.DMR (monthly)</b> Data format: ASCII

\* For details on the file name "Mddhhmma.extension," see appendix 3.

## Display Data and Event Data

The measured/computed data is written to the internal memory of the DX100P at a specified interval as display data or event data from the time Memory Start\* is executed to the time Memory Stop\* is executed and automatically saved to the external storage medium at a specified interval. You can select whether to save the measured/computed data as display data or event data (see section 4.3).

\* For details on Memory Start and Memory Stop, see section 1.5.

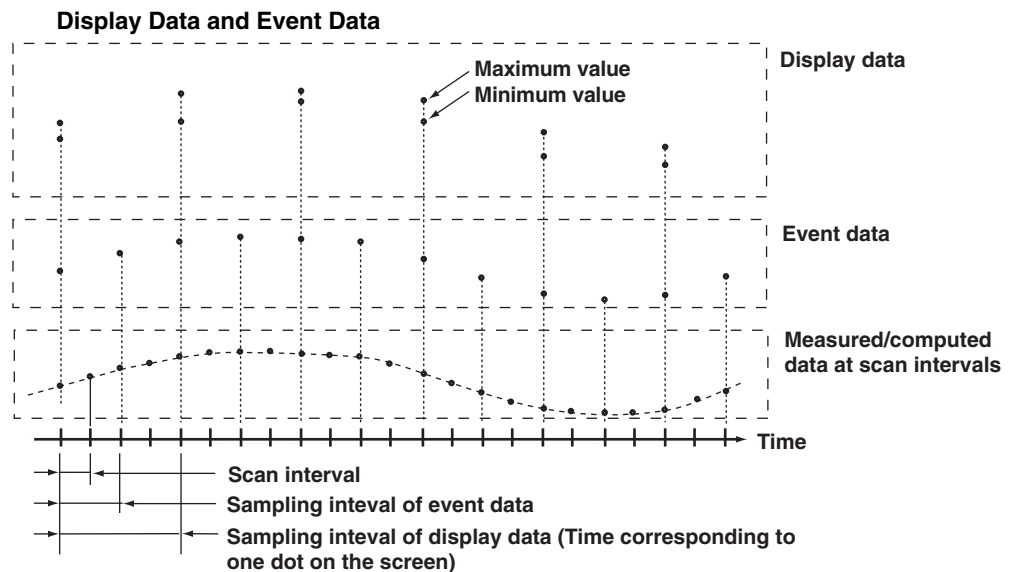

**Display data** are used to display waveforms on the DX100P's screen. Display data consists of maximum and minimum values of the measured or computed data sampled at the scan interval within the time period corresponding to one dot on the time axis on the screen.

The time period corresponding to one dot is called “the sampling interval of display data.” The sampling interval of display data is determined by the display update rate. The relationship between the display update rate and the sampling interval of display data is as follows:

Display Update Rate (/div)	15 s*	30 s*	1 min	2 min	5 min	10 min	15 min	20 min	30 min	1 h	2 h	4 h	10 h
Sampling interval of display data (s)	0.5	1	2	4	10	20	30	40	60	120	240	480	1200

\* for DX102P and DX104P only

Display data can be likened to the conventional recording on the chart sheet and are useful for long-term data acquisition.

**Event data** are instantaneous values of the measured/computed data at specified sampling intervals. The sampling interval can be selected from the selections below. You cannot specify a sampling interval that is faster than the scan interval. For the setting procedure, see section 4.3.

DX102P, DX104P: 125 ms, 250 ms, 500 ms, 1 s, 2 s, 5 s, 10 s, 30 s, 60 s, 120 s, 300 s, and 600 s

DX106P, DX112P: 1 s, 2 s, 5 s, 10 s, 30 s, 60 s, 120 s, 300 s, and 600 s

By setting the sampling interval equal to the scan interval, all measured/computed data sampled at the scan interval can be saved. This is useful when you wish to acquire the measured/computed data in detail.

### Channels for Saving the Display Data / Event Data

You can specify the channels to save the display data or event data. For the procedure, see section 4.3. By default, the data of all measurement/computation channels is set to be saved.

### Acquiring Display Data/Event Data to the Internal Memory

The size of the internal memory for acquiring display data or event data is 5 MB<sup>\*1</sup>. The display data or event data in the internal memory is divided into blocks according to the timing<sup>\*2</sup> used to save data to the external storage medium. When the acquisition area is full or when the number of blocks<sup>\*3</sup> in the internal memory exceeds 16, data is overwritten from the oldest data.

\*1 For details on how to estimate the maximum sampling length from the number of channels which data is to be acquired to and the sampling interval, see appendix 4.

\*2 See the section “Saving Display Data and Event Data to the External Storage Medium.”

\*3 The display data or event data in the internal memory can be confirmed using memory summary (see section 7.4).

When the acquisition area is full

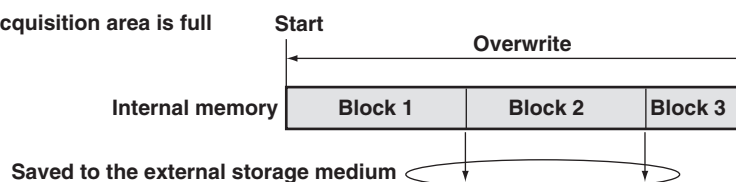

When the number of blocks exceeds 16

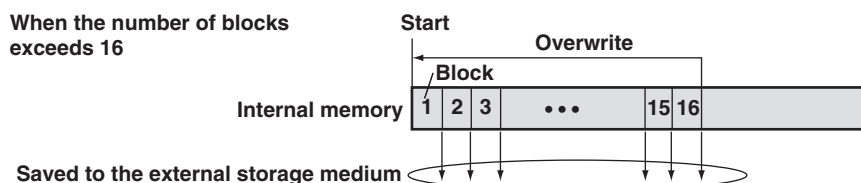

### Type of Process When Saving Display Data and Event Data

You can set the type of process to “Batch” or “Continue”(Continuous). “Batch” is suitable for managing data at the batch level through batch process. “Continuous” is suitable for managing data of a process that is continuously run through the rotation of operators or administrators.

The following points differ between “Batch” and “Continuous.”

Saving of the Data to the External Storage Medium

- **“Batch”**

Data is saved so that 1 data file/batch is achieved as much as possible.

- The interval for saving the data in the internal memory to the external storage medium is fixed\* to the maximum interval that can be specified on the DX100P. If the acquisition to the memory is stopped before 1 interval elapses, 1 data file/batch is achieved.

\* The value varies depending on the number of channels of data that is saved and the sampling interval.

- Data cannot be saved using key operation.

- **“Continuous”**

You can select the interval for saving the data in the internal memory to the external storage medium.

### Signing Data Files (Adding Approval Information)

- **“Batch”**

In the case of 1 data file/batch, the file can be signed using the DX100P or the DAQSIGNIN that came with the package.

If a single batch of data is made up of multiple files, the DX100P cannot be used to sign the data. You can use the DAQSIGNIN software that came with the package.

\* In the DAQSIGNIN, the batch can be handled as 1 data file/batch.

- **“Continuous”**

You can use either the DX100P or the DAQSIGNIN software that came with the package to sign each data file.

## Saving Display Data and Event Data to the External Storage Medium

### Type of External Storage Medium

The measured/computed data in the internal memory can be saved to the following external storage media.

- Zip disk (100 MB or 250 MB)
- Flash memory card (4 MB to 440 MB): The size varies depending on the memory card that you are using.

### Note

- Use an external storage medium formatted to "FDISK 1 partition (hard disk format)."
- If a memory card larger than 32 MB is formatted using Windows XP, FAT32 is selected by default. The DX100P cannot use memory cards formatted to FAT32. When formatting a memory card on Windows XP, select FAT for the file system.

### Information Saved to the Display Data and Event Data Files

The following information is saved to the display data and event data files.

#### Content of the display data and event data files

- Header string (see section 5.7)\*
- Batch information (see "Batch Function" in section 1.5)
- Measured/computed data
- Setup data while running
- Login information (see "Login Function" in section 1.5)
- Operation log (see "Audit Trail Function" in section 1.5)
- Alarm summary
- Alarm ACK summary
- Message summary

Approval information  
(see "Electronic Signature Function" in section 1.5)

← Added after data acquisition to the memory is stopped.

\* The header string is common to the manual sampled data, TLOG data (option), and report data (option).

### Note

The limitation on the number of alarm information, message information, and operation logs that can be stored to the internal memory are shown below. When the maximum number is exceeded, the information is overwritten from the oldest information. Therefore, if the alarm information, message information, or operation log exceeds its maximum number before the display data/event data is saved to the external storage medium, the overwritten information is not stored to the display data/event data file.

Alarm information: 240 max. Message information: 250 max. Operation log: 2000 max.

### Data Save Destination Directory (See Page 1-28)

You can specify the name of the save destination directory on the external storage medium (up to 8 alphanumeric characters. Initial value is "DATA0") (see section 5.7).

- \* Display data, event data, manual sample data, TLOG data, report data, and screen image data files are saved to this directory.

### Note

Back up the data on the external storage medium.

## 1.4 Measured/Computed Data Save Function

### Auto Save

The display data/event data in the internal memory is saved automatically to the external storage medium according to the timing shown below. For the procedure, see section 4.3.

- Every interval indicated below
  - Display data
    - Auto save interval (10 minutes to 31 days<sup>\*1</sup>, see section 5.6)
    - Fixed to the maximum selectable interval<sup>\*2</sup> if the process type is set to "Batch."
  - Event data
    - Data length (3 minutes to 31 days<sup>\*1</sup>, see section 4.3)
    - Fixed to the maximum selectable data length<sup>\*2</sup> if the process type is set to "Batch."
- \*1 The selections vary depending on the number of channels of data that is saved and the sampling interval.
- \*2 The value varies depending on the number of channels of data that is saved and the sampling interval.
- Specified time
 

You can specify a time to save the data as follows. This operation is called "data saving through **memory timeup**."

  - \* Batch data file saved using memory timeup cannot be signed on the DX100P (see page 1-37).
  - Every hour on the hour
  - Specified hour on the hour every day
  - Specified hour on the hour on the specified day every week
  - Specified hour on the hour on the specified day every month
- When the acquisition to the memory is stopped

### Examples of data save operation to the external storage medium

#### Example 1

**Auto save interval or data length: 1 day**

**Date and time when data is saved to the external storage medium: Not use**

After starting at 13:10, data is saved every 24 hours after (at 13:10 everyday).

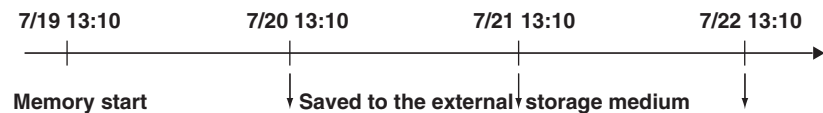

#### Example 2

**Auto save interval or data length: 1 day**

**Date and time when data is saved to the external storage medium: 0 hour every day.**

After starting at 13:10 on July 19th, data is saved at 0 hour on July 20th and then every day after and at 0 hour every day (the same time for both in this example).

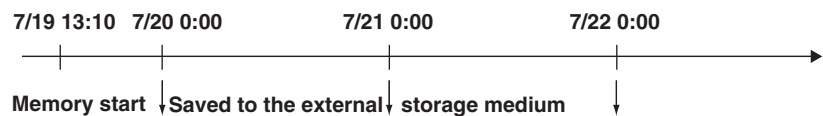

#### Example 3

**Auto save interval or data length: 12 hours**

**Date and time when data is saved to the external storage medium: 0 hour every day.**

After starting at 13:10 on July 19th, data is saved at 0 hour on July 20th and then every 12 hours after and at 0 hour every day (0 hour occurs at the same time as the 12 hour timing).

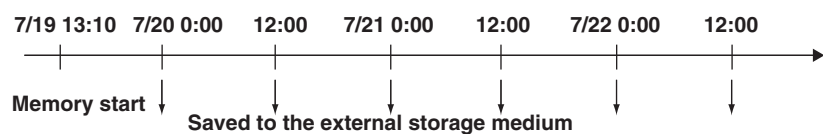

#### Example 4

**Auto save interval or data length: 2 day**

**Date and time when data is saved to the external storage medium: 0 hour every day.**

After starting at 13:10 on July 19th, data is saved at 0 hour on July 20th and then every 2 days after and at 0 hour every day (the 2-day timing occurs at the same time as 0 hour).

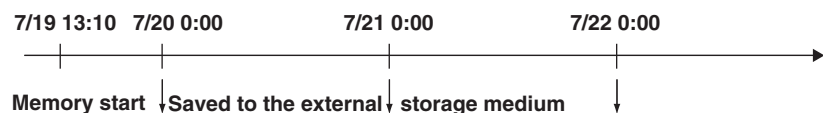

If the process type is set to “Batch” and the acquisition to the memory is stopped before the specified interval elapses, 1 data file/batch is achieved.

If the acquisition to the memory is stopped before the first auto save interval or data length, 1 data file/batch results. Data is saved at every prescribed interval (T) and when the acquisition to the memory is stopped.

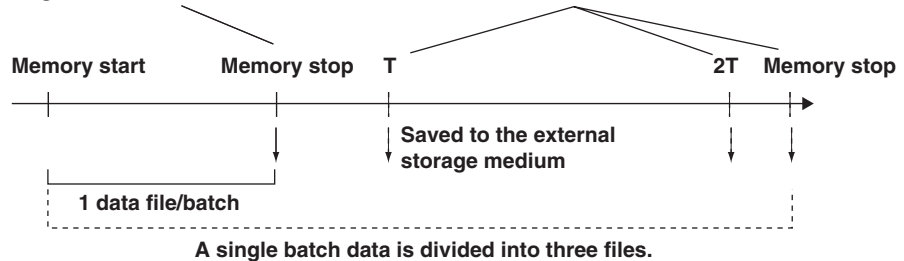

**Saving Data Using FUNC Key Operation (Only When the Process Type Is Set to “Continuous”)**

Through FUNC key operation, display data/event data can be saved to the external storage medium at an arbitrary time after memory start. For the operating procedure, see section 8.6.

Below is the behavior of the DX100P when this operation is executed.

• **When Saving Data at Auto Save Intervals (Display Data) or Data Length (Event Data)**

Saving of the data is repeated at auto save intervals or every data length from the point when data is saved through key operation.

**Example: When auto save interval or data length is set to 1 hour**

Example: When auto save interval or data length is set to 1 hour

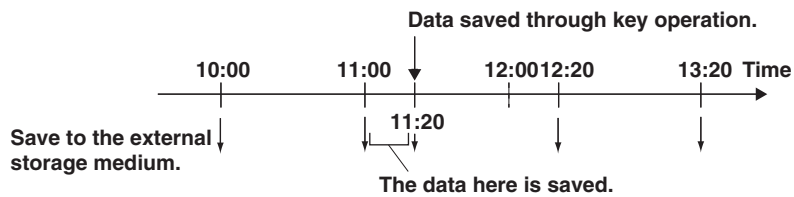

**Note**

The save operation using the auto save interval or data length is executed by counting the auto save interval or data length from the last time the data was saved.

• **When Saving Data at Specified Times**

The operation continues without change after saving the data through key operation.

Example: When data is saved every hour on the hour

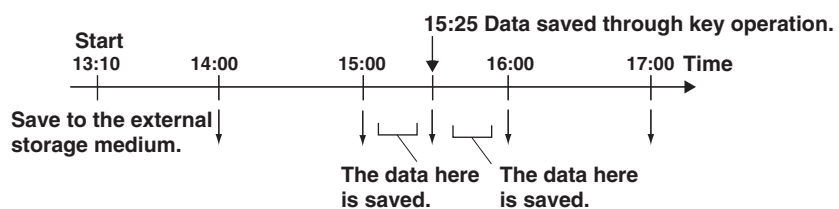

**Note**

If the saving of the data to the external storage medium is not complete due to reasons such as insufficient free space, the following operation takes place.

- The next time data is saved to the external storage medium, unsaved data is also saved.
- If Memory Start is not executed, the unsaved data is saved when the operation cover is closed.
- You cannot execute Memory Start when unsaved data exists.

**Manual Sampled Data**

- When the manual sample operation is executed, the instantaneous values of all channels (excluding the measurement channels that are set to Skip and the computation channels that are turned Off) are acquired to the internal memory.

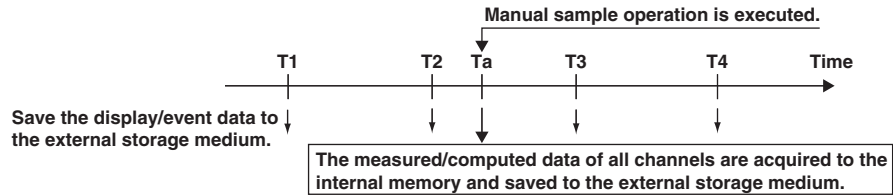

- Up to 50 data sets can be stored to the internal memory. When this number is exceeded, data are overwritten from the oldest data.
- The first time manual sample is executed, a manual sampled data file is created on the external storage medium. The data are appended to this file for each successive manual sample operation.

For the operating procedures, see section 8.3.

**Note**

- The number of manual sampled data in the internal memory can be confirmed on the memory summary (see section 1.3).
- When there is no medium in the drive at the time when manual sample is executed, all unsaved data are saved the first time when manual sample is executed, after the storage medium is reinserted into the drive.
- A character string can be set as a file header (see section 5.7).

**TLOG Data (Only on models with the optional computation function (/M1))**

- TLOG data is created from the time computation is started to the time computation is stopped.
- The instantaneous values of all channels (excluding the measurement channels that are set to Skip and the computation channels that are turned Off) are acquired to the internal memory at each time interval set by timers and when the computation is stopped.

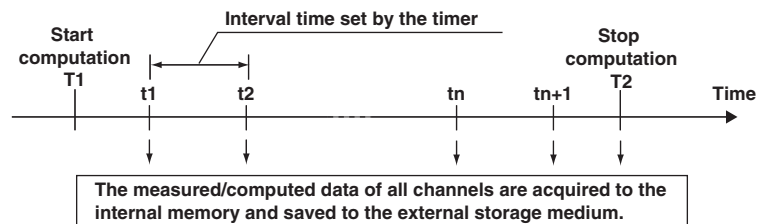

- Up to 400 data sets can be stored to the internal memory. When this number is exceeded, data are overwritten from the oldest data.
- The first time TLOG data are acquired, a TLOG data file is created on the external storage medium. The data are appended to this file at each time interval. When the number of TLOG data sets exceeds 400, a new file is created.

For the setting procedures, see section 4.7.

**Note**

- Up to 16 blocks (number of computation start/stop operations) of TLOG data can be stored to the internal memory. When the number of blocks in the internal memory exceeds 16, TLOG data are overwritten even if the number of data sets is less than 400.
- The number of TLOG data sets in the internal memory can be confirmed on the memory summary (see section 1.3).
- When there is no medium in the drive at the time when data are supposed to be saved, all unsaved data are saved the first time when the interval time expires after the storage medium



is reinserted into the drive.

- A character string can be set as a file header (see section 5.7).

### Report Data (Only on Models with the Optional Computation Function (/M1))

- A report is created from the time Memory Start is executed to the time Memory Stop is executed.
- The average, maximum, minimum, and sum can be computed for the specified channels at predetermined intervals and the result can be stored to the internal memory.
- You can select one hour (hourly report), one day (daily report), one hour/one day (hourly and daily report), one day/one week (daily and weekly reports), or one day/one month (daily and monthly reports) for the interval.

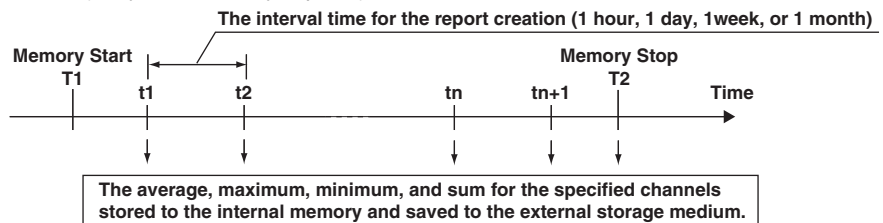

- Up to 50 data sets can be stored to the internal memory. When this number is exceeded, data are overwritten starting with the oldest data. When “daily and monthly reports” is specified, for example, the total number of daily and monthly reports that can be stored in the internal memory is 50.
- The first time report computation is executed, a report data file is created on the external storage medium. A file is created for each type of report such as hourly, daily, weekly, and monthly reports. The data are appended to this file at each time interval.

#### Dividing Report Files

The report files are divided at the following times.

- When the data acquisition is stopped (Memory Stop).
- For hourly reports
  - When the 0:00 report is created every day.
  - When the number of data sets in the file reaches 25.
- For daily reports
  - When the report for the first day of the month is created every month
  - When the number of data sets in the file reaches 32.

For the setting procedures, see section 4.6.

#### Note

- The number of report data sets in the internal memory can be confirmed on the memory summary (see section 1.3).
- When there is no medium in the drive at the time when data are supposed to be saved, all unsaved data are saved the first time when the interval time expires after the storage medium is reinserted into the drive.
- A character string can be set as a file header (see section 5.7).

## Using the External Storage Medium

### Directory Structure

The external storage medium consists of directories shown in the figure below.

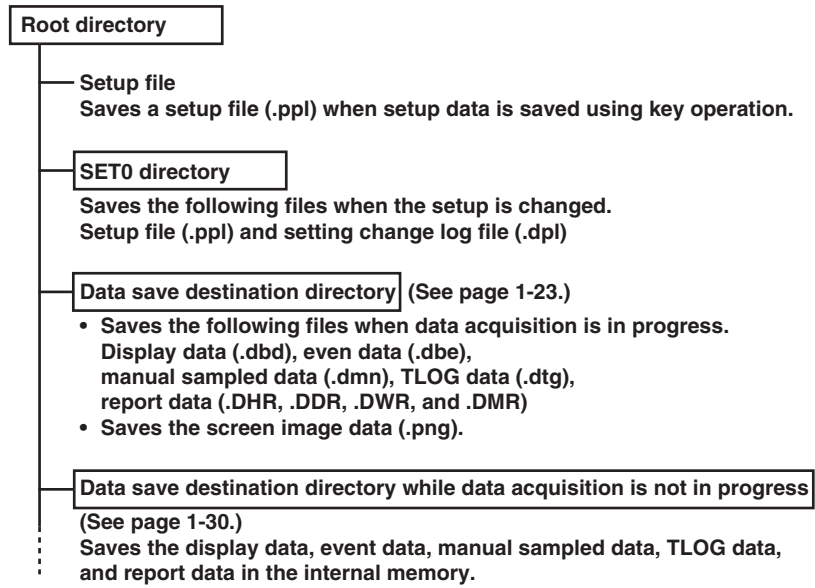

### Replacing the External Storage Medium

A message appears when there is not enough free space on the external storage medium. Replace the storage medium before the data in the internal memory is overwritten.

### Cyclical Use of the Storage Area of the External Storage Medium (Media FIFO)

This method constantly saves the newest files to the external storage medium. This method enables a single storage medium to be used continuously.

- **Operation**

When the free space on the external storage medium becomes small, the oldest file in the save destination directory is deleted, and the newest file is saved. This operation is referred to as FIFO (First In First Out).

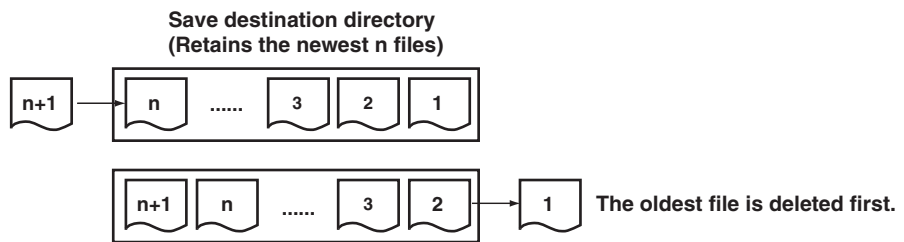

- **FIFO Operation in the Data Save Destination Directory**

Retains up to the newest 1000 files.

- **FIFO Operation in the SET0 Directory**

Retains up to the newest 100 files.

**Note**

- If the free space on the storage medium after saving the file is less than 1 MB, the oldest files are deleted in order from the save destination directory before saving the file. A free space of at least 1 MB is available after saving the file.
- All the files in the save destination directory are applicable to be deleted.
- If enough free space cannot be obtained even when the files are deleted, the data is not saved.
- FIFO operation is carried out even when more than 1000 files exist in the data save destination directory from the beginning.
- If directories other than the data save destination directory are created on the storage medium, the area that can be used for the data save destination directory is reduced. It is recommended that a storage medium dedicated solely to saving data be used.
- File Division  
Manual sampled data files, report data files (hourly or monthly), and setting change log files are often excluded from files that are deleted, because the date of creation of these files is updated each time new data is added. To prevent this problem, these files are divided when the file exceeds 100 KB only when FIFO operation is specified. Below are estimations of the amount of data that can be saved to a divided 100-KB file.
  - Manual Sampled Data Files  
3525 or 388 samples when the number of channels is 1 or 30, respectively
  - Report Data Files (Hourly and Monthly)  
When the number of report channels is 30: 48 weeks for weekly and 48 months for monthly
  - Setting change log files  
1161 logs or less

**• When an Error Occurs on the Storage Medium**

- The following alarms are output when an alarm occurs on the storage medium.
- The external storage medium icon in the status display section changes to an error indication.
  - Memory end output is possible using the system relay (/F1 option).
  - An E-mail can be transmitted (see IM04L05A01-17E).
  - The error is output as status information via the communication interface (see IM04L05A01-17E).

**Note**

If a normal storage medium is detected such as by replacing the storage medium, the storage medium error status is cleared.

### Data Storage While Data Acquisition Is Stopped

The data in the internal memory can be saved to an external storage medium when data acquisition is stopped. This operation can be carried out only by an administrator. For the operating procedure, see section 5.24.

#### Data That Are Saved

The display data, event data, manual sampled data, TLOG data, and report data in the internal memory are saved.

#### Save Destination Directory (see page 1-28)

The data saved using this method is saved to the following directory. The sequence number of the directory name is incremented by 1 each time the data save operation is carried out.

“The specified directory name”.A\*\* (where \*\* is a sequence number)

#### Precautions to Be Taken When Using Display Data Files and Event Data Files

- Use the display data files and event data files as reference data.  
The login information, setup data, alarm summary, operation log, message summary, and acknowledge information that exist at the time data save operation from the internal memory is carried out are saved to the display data files and event data files. The information may be different from the information when the data was stored by the auto save function.
- The file name in file information is displayed in red.  
To distinguish these files from those saved by the auto save function, the file names of these files are displayed in red in the file information (see section 8.7).

### Saving Data via Ethernet

The display data, event data, report data, and screen image data can be automatically transferred to an FTP server via Ethernet for storage. Conversely, the DX100P can operate as an FTP server. In this case, the DX100P is accessed from a PC and the files on the external storage medium can be retrieved for storage. For details on these functions, see the DX100P/DX200P Communication Interface User's Manual (IM 04L05A01-17E).

## 1.5 Function for Managing Measured/Computed Data

### Relationship between the Operations on the DX100P and the Function for Managing Data

The measured/computed data of the DX100P can be managed using the login function, batch function, audit trail function, and electronic signature function. The following figure indicates the operations on the DX100P and each of the functions.

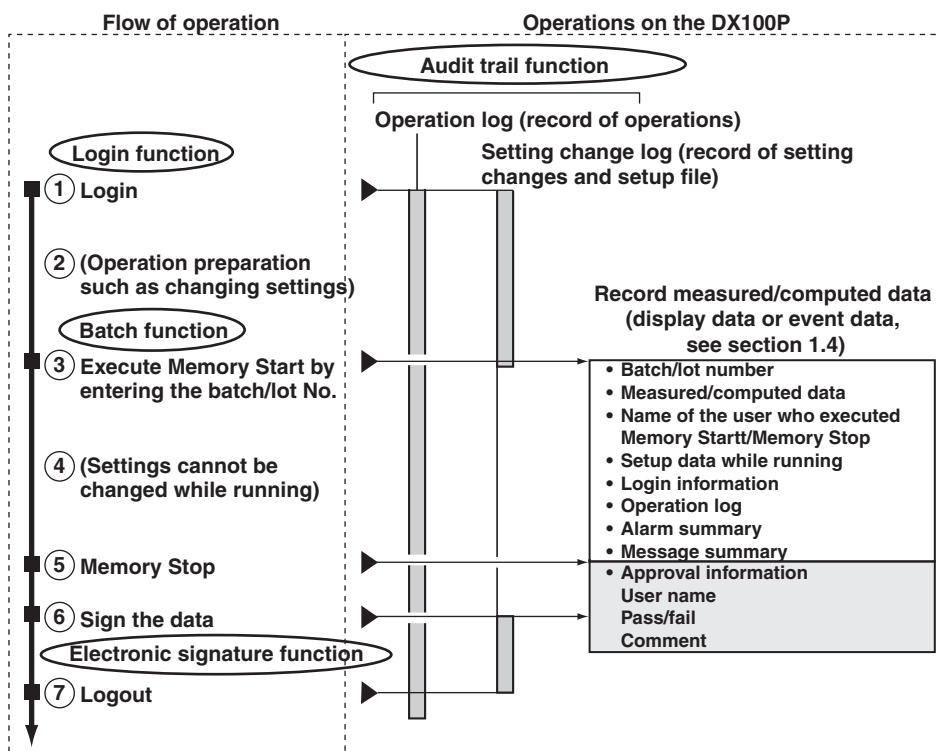

#### Explanation of Terminology

- **Login/logout**

Login refers to the steps taken by the user who is registered in the DX100P to enable operations on the DX100P by entering the user name, user ID, and password. Logout refers to the steps taken to terminate the login condition.

- **Memory Start/Memory Stop**

Operation for starting or stopping the recording of the display data or event data. When Memory Start is executed, the display data or event data is acquired to the internal memory at a specified interval and automatically saved to the external storage medium.

- **Electronic Signature Function and Sign**

The electronic signature function is used to add approval information (pass or fail) to data files by checking the saved data. Sign refers to the action of adding such information. This corresponds to electronic signature.

- **Audit Trail Function**

This function saves information used to check the past run progress.

- **Log**

This log contains records such as operations in order of occurrence in a predetermined format.

#### Note

The measured/computed data of the DX100P is saved to the external storage medium. Make sure to back up the data.

### Login Function

The DX100P can be used only by the users that have been registered beforehand. You are required to enter ID information (user name, user ID, and password) to log in in the following cases.

- When the DX100P is turned On.
- When the system mode is ended.
- When you log in after logging out.

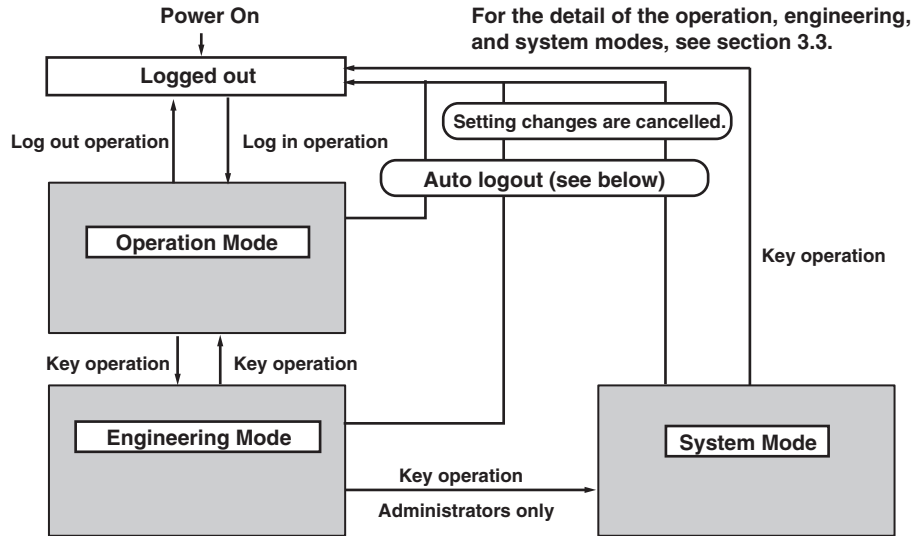

#### Auto Logout

You can set the DX100P so that users are logged out automatically if there is no key operation for a specified time (see section 4.4). If a user is logged out automatically from the engineering and system modes, the setting changes are cancelled.

#### Operations That Can Be Carried Out When Logged Out

When logged out, the operation screen can be switched using the DISP/ENTER key and arrow keys. However, alarm ACK operation on the overview screen and changing of the screen when displaying the sign record screen (see section 4.4 for the setup procedure) are not possible.

#### Types of Users

A user can be an “administrator” or a “user.” For details on the settings, see section 4.4. For details on the operating procedure, see section 6.1.

- **Administrator**

Administrators can perform all operations on the DX100P.

Item	Description
Number of administrators that can be registered	3
Range of operations	All operations.
Login method	You can select from login only using keys or login using keys and via communications.
ID information	<ul style="list-style-type: none"> <li>• User name (up to 20 alphanumeric characters)</li> <li>• User ID (you can specify whether to use the user ID,. Up to 8 alphanumeric characters.)</li> <li>• Password (You can set the password expiration. 6 to 8 alphanumeric characters.)</li> </ul>

#### Note

At least one administrator must be registered to use the login function. If there is no administrator registered, the login function is disabled (the DX100P can be operated without logging in). In addition, the electronic signature function cannot be used.

**User**

Users are registered by the administrator.

Item	Description
Number of users that can be registered	90
Range of operations	<p>Operations in the system mode is prohibited.</p> <p>Each user is allowed to perform specific operations that have been assigned. Possible operations are shown below.</p> <ul style="list-style-type: none"> <li>• Sign record operation</li> <li>• START key operation</li> <li>• STOP key operation</li> <li>• MENU key operation</li> <li>• USER key operation<sup>*1</sup></li> <li>• DISP/ENTER key operation<sup>*2</sup></li> <li>• Alarm ACK operation (on the overview screen/USER key<sup>*1</sup>)</li> <li>• Zip disk eject operation (for models with the Zip drive)</li> <li>• Batch number/lot number write operation, comment write operation (FUNC key)</li> <li>• Message write operation (FUNC key/USER key<sup>*1</sup>)</li> <li>• Snapshot operation (FUNC key/USER key<sup>*1</sup>)</li> <li>• Computation start/stop, computation reset, computation dropout ACK operations (for models with the computation option (/M1), FUNC key/USER key<sup>*1</sup>)</li> <li>• Display data save (FUNC key)<sup>*3</sup>, event data save (FUNC key)<sup>*3</sup>, manual sample operation (FUNC key/USER key<sup>*1</sup>)</li> <li>• Display data load, event data load (FUNC key)</li> <li>• E-mail start/stop, e-mail test (FUNC key)</li> <li>• Other operations (assign names to the four screens, display logs, display a list of files in the external storage medium, change the password, perform an FTP test, and display the “Modbus Status” screen) (FUNC key)</li> <li>• Calibration correction setting</li> </ul>
Login method	You can select from login only using keys, login only via communications, or login using keys and via communications.
ID information	<ul style="list-style-type: none"> <li>• User name (up to 20 alphanumeric characters)</li> <li>• User ID (you can specify whether to use the user ID,. Up to 8 alphanumeric characters.)</li> <li>• Password (You can set the password expiration. 6 to 8 alphanumeric characters.)</li> </ul>

\*1 Even if the operation of the USER key is enabled, if the action assigned to the USER key is disabled, the action is not executed when you press the USER key.

\*2 If the DISP/ENTER key operation is disabled, you cannot perform an alarm ACK operation on the overview display nor assign a name to the 4 screen display.  
Even if the DISP/ENTER key operation is disabled, you can use the DISP/ENTER key on the sign record screen and in the engineering mode.

\*3 Operation is not allowed, if the type of process is set to “Batch” (settings made here are invalid).

**User ID and Password**

The combination of the user ID and password must be unique.

**User Locked**

If the user enters a wrong password three consecutive times when prompted to enter the password, the user is invalidated and can no longer log in.

For the procedure in clearing the user locked condition, see section 6.1.

**Saving and Loading Login Information (see section 4.12)**

The login information refers to the settings of the “Admin tool” as described in section 4.4. It contains user information and information on the usage method of the login function and signin function.

The information is set in the system mode. It is distinguished from other settings of the system mode as “login information.”

## 1.5 Function for Managing Measured/Computed Data

- **Saving Login Information**

Login information is saved within the setup file (.ppl extension)\*.

\* For details on the file name, see appendix 3.

- **Loading Login Information**

Login information can be loaded from a setup file (.ppl extension) on the external storage medium and used as login information of the DX100P. When login information is loaded, the passwords of all administrators and users are reset to their default passwords (see section 6.1).

### Log in via the Ethernet

Only one type of login is possible at a time.

- Login using keys

- Connection to the setting function via the Ethernet (see IM04L05A01-17E).

\* Connection from the DAQSIGNIN via the Ethernet belongs to this type (see IM04L05A01-61E).

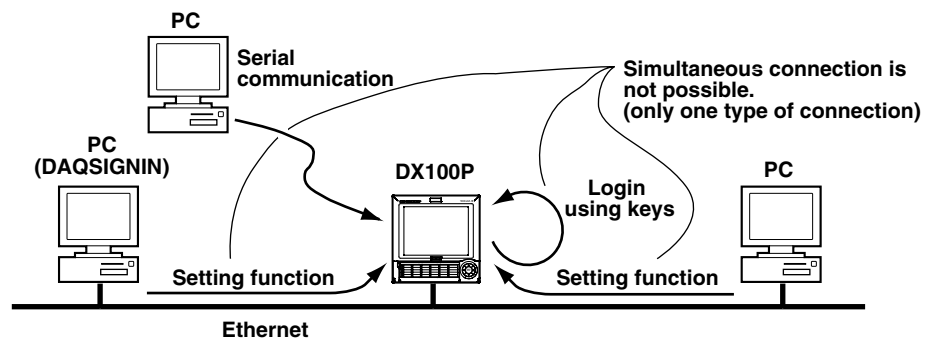

## Batch Function

You can add batch information to the display data/event data file.

### Batch Number and Lot Number

Batch numbers and lot numbers can be added to display data/event data files. The file name can be identified using "batch number-lot number."

- Batch number (up to 32 characters).
- Lot number (up to 8 numbers)

The lot number does not have to be specified.

### Automatic Increment of the Lot Number

The lot number can be automatically increased by one at Memory Stop. For the setting procedure, see section 5.17.

### Other Batch Information

- The following information can be added to the display data/event data files. For details on the settings, see section 5.17, 6.2, and 8.1.
  - Header 1 (up to 64 characters).
  - Header 2 (up to 64 characters).
  - Header 3 (up to 64 characters).
  - Comment information.
    - Comment 1 (up to 32 characters).
    - Comment 2 (up to 32 characters).
    - Comment 3 (up to 32 characters).
    - Date and time when the comment was written and user name
- The following information is automatically added to the display data/event data files.
  - Serial number of the DX100P (the number written on the name plate of the DX100P).
  - Date and time of Memory Start and user name
  - Date and time of Memory Stop and user name



### Audit Trail Function

Operation log, setting change log, and the setup file at that point are saved as information regarding the progress of operation.

#### Operation Log

The operation on the DX100P is logged in the order of occurrence. Logs of up to 2000 operations can be recorded to the internal memory. When the number of logs exceed 2000, the log is overwritten from the oldest log.

- **Operations That Are Logged**

Key operations on the DX100P, operations through the remote control function (/R1 option), and via the communication are logged. For a description on the operations that are logged and the display, see appendix 5.

- **Saving the Operation Log**

The operation log from the last memory stop to the current memory stop is saved within **the corresponding display data/event data file**.

- **Displaying the Operation Log**

- Displayed through FUNC key operation (see section 8.9).
- When signing the recorded data file, you can display the operation log within the file and confirm the information.

The number of the log displayed on the last line

Total number of logs				
(0012/0050)	Time	Action	User Name	
Nov. 19	10:57:37	Snapshot	ABC2001	
Nov. 19	10:54:48	AlarmACK	ABC2001	[R]
Nov. 19	10:54:41	Manual	ABC2001	[R]
Nov. 19	10:51:48	Manual	ABC2001	
Nov. 19	10:51:41	Message	ABC2001	
Nov. 19	10:51:05	MathStart	ABC2001	
Nov. 19	10:51:05	MemStart	ABC2001	
Nov. 19	10:50:38	Login	ABC2001	
Nov. 19	10:50:18	Error111		
Nov. 19	10:49:44	Logout	ABC2001	
Nov. 19	10:49:25	SysSet	ABC2001	
Nov. 19	10:48:09	MathStop	ABC2001	

Name of the user who performed the operation

Operation information

Date and time when operation was performed

Operation type  
(see the description below.)

None: Key operations

[R]: via the remote control function (/R1 option)

[M]: On the setting function of the setting/measurement server via the Ethernet<sup>\*1\*2</sup>

[m]: On the monitor function of the setting/measurement server via the Ethernet<sup>\*1</sup>

[T]: On the setting function of the Maintenance/test server via the Ethernet<sup>\*1</sup>

[t]: On the monitor function of the Maintenance/test server via the Ethernet<sup>\*1</sup>

[F]: On the FTP server via the Ethernet<sup>\*1</sup>

[S]: via the serial communications (/C2, /C3 options)<sup>\*1</sup>

[P]: User locked on the DAQSIGNIN<sup>\*2</sup>

[Y]: Auto operation by the DX100P<sup>\*3</sup>

\*1 See IM04L05A01-17E.

\*2 See IM04L05A01-61E.

\*3 Such as the periodic time adjustment using the SNTP function.

- **Clearing the Operation Log**

The operation log in the internal memory is cleared when initialization (clear 1) is executed in the system mode.

The operation log in the display data/event data file cannot be cleared.

## 1.5 Function for Managing Measured/Computed Data

### Setting Change Log and Setup File

When settings are changed, the setup file after the change is saved to the external storage medium. At the same time, the log of the setting change is recorded to the internal memory and saved to the external storage medium. **There is a one-to-one relationship between the saved setup file and the setting change log. They contain the same numbers that are assigned in the order of occurrence.**

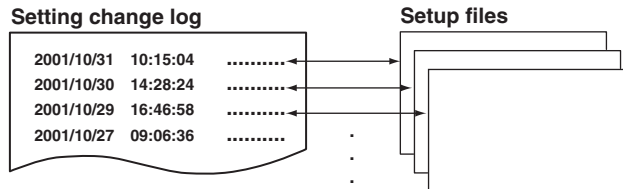

- **Operations That are Saved**
  - Setting change of engineering mode items\* (see chapter 5)
  - Setting change of system mode items\* (see chapter 4)
    - \* "File operation" items (load/save settings and load/save login information) are excluded.
- **Setup file**
  - **Saving the Setup File**

The setup file (.PPL extension) is saved to the SET0 directory of the external storage medium.

    - \* For details on the file name, see appendix 3.
  - **Displaying the Setup File**

DAQSIGNIN provided with the package can be used to view the information.
- **Setting Change Log**
  - **Saving the Setting Change Log**

Up to 200 setting change logs are recorded to the internal memory. When the number of logs exceed 200, the log is overwritten from the oldest log.

The setting change log file (.DPL extension) is created in the SET0 directory of the external storage medium and the logs are added.

    - \* For details on the file name, see appendix 3.
  - **Displaying the Setting Change Log**

Displayed through FUNC key operation (see section 8.9). **The numbers that are assigned in the order of occurrence are not displayed. This number can be confirmed using the DAQSIGNIN that came with the package.**

The number of the log displayed on the last line  
Total number of logs

(012/015)	Time	File Name	User Name
Nov.19	10:49:25	Y1910491	ABC2001
Nov.19	10:25:03	Y1910251	ABC2001
Nov.19	10:12:33	Y1910121	ABC2001
Nov.19	07:04:44	Y1907041	ABC2001
Nov.19	07:01:39	Y1907011	ABC2001
Nov.19	06:55:06	Y1906551	ABC2001
Nov.16	14:44:27	Y1614441	ABC2001
Nov.16	14:35:07	Y1614351	ABC2001
Nov.16	14:28:00	Y1614281	ABC2001
Nov.16	13:16:04	Y1613161	ABC2001
Nov.16	12:36:56	Y1612361	ABC2001
Nov.16	12:33:35	Y1612331	ABC2001

Name of the user who changed the settings  
 Setup file name that was saved  
 Date and time when settings were changed

- **Clearing the Setting Change Log**

The setting change log in the internal memory is cleared when initialization (clear 1) is executed in the system mode.

### Electronic Signature Function

This function is used to add the following approval information to the displayed data/event data files that are saved on the external storage medium.

- **Pass or fail**
- **Comment**
- **Name of the user who added the information and the date and time when the information was added**

#### Files That Can Be Signed and Signing Procedure

The signing procedure varies depending on the type of process (“Batch” or “Continuous”) that was used when the data was acquired.

##### For "Batch" process

When the batch data is saved in units of 1 data file/batch

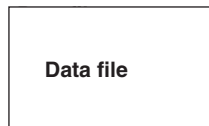

- Can be signed using the DX100P
- Can be signed using DAQSIGNIN

When a single batch data is made up of multiple files



- Cannot be signed using the DX100P\*1
- Can be signed collectively using DAQSIGNIN\*2
- Files can be combined to a single file using DAQSIGNIN.

\*1 Because signing at the file level is prohibited for batch data.  
\*2 Because the data of all files can be viewed and confirmed at once using DAQSIGNIN.

##### For "Continuous" process



- Can be signed at the file level using the DX100P.
- Can be signed at the file level using DAQSIGNIN.

#### Signing Using the DX100P

Signing record screen is used. For details on the displayed information, see “Sign Record Screen” in section 1.3. For details on the operating procedure, see section 6.3.

- You can set the signing record screen to automatically appear when memory stop is executed (see section 4.4).
- You can load display data/event data files saved on the external storage medium using key operation and sign them (see section 8.7).

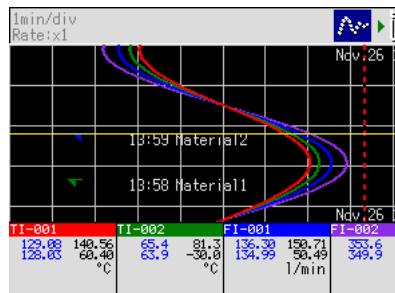

## 1.5 Function for Managing Measured/Computed Data

---

### User That Can Sign and Sign Authority Level

- Logged-in user can sign the files. However, users without sign authority cannot sign.
- Three different authority levels of signs can be placed on a single display data/event data file (Sign1, Sign2, and Sign3). **You can assign meanings to Sign1, Sign2, and Sign3. For example, Sign1, Sign2, and Sign3 can be assigned to the operator, the quality control personnel, and the manager, respectively.**
- The administrator can sign at all authority levels.
- Each user is assigned a sign authority level by the administrator. Users can sign using the assigned authority level. However, users without sign authority level can be specified.
- Sign at the same authority level is allowed once.

### Confirming the Data

When signing files, the following information can be confirmed on the sign record screen.

- **Measured/computed values and waveforms**
- **File information** (batch number/lot number, serial number of the DX100P, Memory Start/stop time, operation user name, header string, comment, and sign record information)  
For a display example, see section 6.3.
- Operation log (for a display example, see section 6.3)
- Alarm summary (for a display example, see “Alarm Summary” in section 1.3)
- Alarm ACK summary (for a display example, see “Alarm ACK Summary” in section 1.3)
- Message summary (for a display example, see “Message Summary” in section 1.3)

### Canceling the Approval Information

Once approval information is added, it cannot be cancelled or changed.

### Note

---

If the data is damaged, you cannot sign the data. An error message is displayed.

---

### Signing Using DAQSIGNIN

See the DAQSIGNIN User’s Manual, IM 04L05A01-61E.

## Function for Handling Changes Made to the Display Data/Event Data

Display data/event data is in BINARY format, and the format is not disclosed. If the data is altered, the status of the file is set to “damaged” (see section 8.7) and cannot be signed.

## Functions When the Login Function Is Not Used

Below are the operations when the login function is not used (when an administrator is not registered).

- There is no login operation. Operation mode is enabled when the power is turned ON and when system mode is ended.
- The electronic signature function cannot be used.
- You can enter the engineering mode and change settings when data acquisition is in progress. However, you cannot change the range, computation, batch, and display update rate settings. In addition, you cannot enter the system mode.
- The setup file is not saved to the external storage medium even when settings are changed in the engineering mode.

## 1.6 Alarm Function

This function generates an alarm when the measured/computed data meets a certain condition. When an alarm occurs, information notifying the alarm occurrence is displayed on the screen. In addition, a signal can be output from the relay output terminals (/AR1, /AR2, or /A3 option) on the rear panel of the DX100P.

### Alarm Type

#### Number of Alarms

You can set up to four alarms for each channel.

#### Alarm Conditions

The following eight conditions are available:

- **Upper Limit Alarm (H)**

An alarm occurs when the measured value exceeds the alarm value.

- **Lower Limit Alarm(L)**

An alarm occurs when the measured value falls below the alarm value.

#### Upper limit alarm

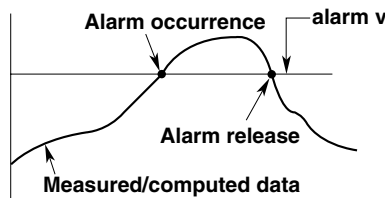

#### Lower limit alarm

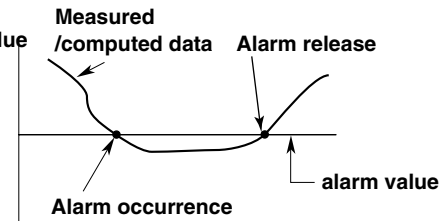

- **Delay Upper Limit Alarm (T)**

An alarm occurs when the measured value remains above the alarm value for the specified time period (delay period).

- **Delay Lower Limit Alarm (t)**

An alarm occurs when the measured value remains below the alarm value for the specified time period (delay period).

#### Delay upper limit alarm example ("T" is the specified delay period)

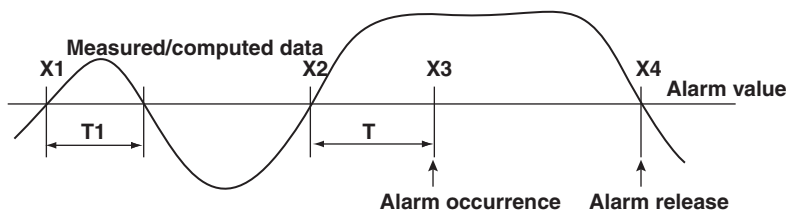

- Alarm does not occur at T1, because the time period is shorter than the specified delay period (T).
- The input exceeds the alarm value at X2, but the alarm occurs at X3 at which the specified delay period elapses (the time when the alarm occurs is the time at X3).
- The input falls below the alarm value at X4 and the alarm is released.

#### Note

Special cases of the delay upper/lower limit alarm

- When delay alarm is set on a computation channel and the computation is stopped in a condition in which the computed value is exceeding the alarm setting, the alarm is turned ON after the specified period (delay period) elapses.
- Alarm detection is reset upon a power failure. It restarts the operation after the power recovers.
- If an alarm is occurring at the time of the alarm setting change and the measured value is exceeding the new alarm setting, the alarm continues.

- Difference Upper Limit Alarm (h)<sup>\*1</sup>**  
 An alarm occurs when the difference between the measured values of two channels becomes greater than or equal to the alarm value.
- Difference Lower Limit Alarm (l)<sup>\*1</sup>**  
 An alarm occurs when the difference between the measured values of two channels becomes smaller than or equal to the alarm value.
  - <sup>\*1</sup> Can be specified only on difference computation channels.
- Upper Limit on Rate-of-Change Alarm (R)<sup>\*2</sup>**  
 The amount of change of the measured values over a certain time interval is checked. An alarm occurs when the amount of increase becomes greater than or equal to the specified value.
- Lower Limit on Rate-of-Change Alarm (r)<sup>\*2</sup>**  
 The amount of change of the measured values over a certain time interval is checked. An alarm occurs when the amount of decrease becomes greater than or equal to the specified value.
  - <sup>\*2</sup> Can be specified only on measurement channels.

Upper limit on rate-of-change alarm

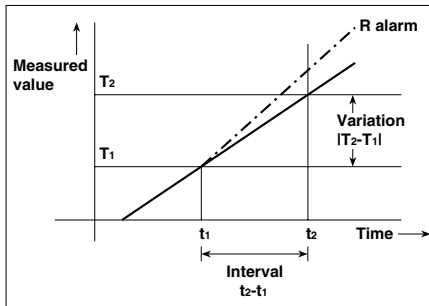

Lower limit on rate-of-change alarm

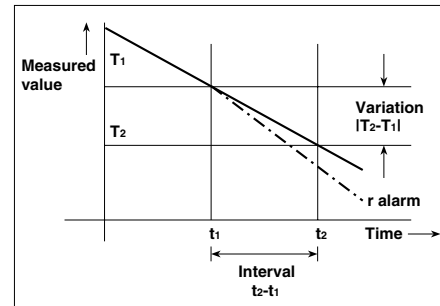

The interval is defined by the following equation and is set in terms of the number of samplings.

$$\text{Interval} = \text{scan interval} \times \text{number of samplings}$$

**Alarm Hysteresis**

This applies to upper (H) and lower (L) limit alarms on measurement channels. A width (hysteresis) can be specified on the value used to set or release the alarm. This prevents the alarm from being set or released repetitively when the measured value is fluctuating around the alarm value. The hysteresis is fixed to 0.5% of the display span (display scale if the range is set to [Scale]). For the setting procedure, see section 4.1.

**Upper Limit Alarm (H)**

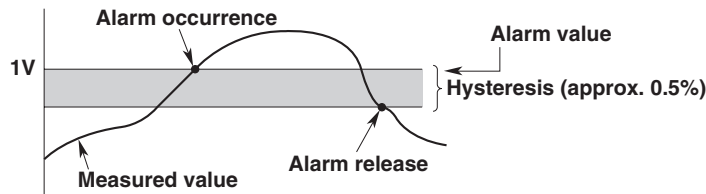

**Lower Limit Alarm (L)**

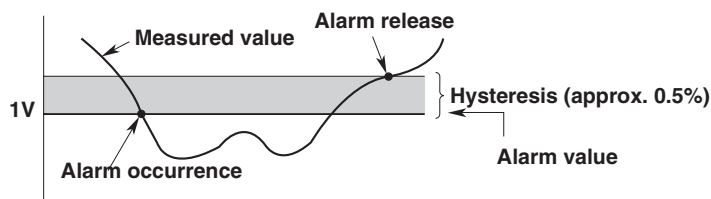

## Alarm Indication

The alarm conditions are displayed as alarm icons in the status display section and through the trend, digital, bar graph, overview and other screens. The detailed information about the alarms is displayed in the alarm summary.

### Alarm Indication Example (Overview screen)

The area corresponding to a channel on which an alarm is occurring is displayed in red.

1	133.1	7	-163.8	31	37
2	108.1	8	-214.6	32	38
3	84.8	9	-142.3	33	39
4	59.9	10	132.3	34	40
5	39.3	11	179.0	35	41
6	17.5	12	125.9	36	42

### Hold/Non-Hold of the Alarm Indicator

There are two methods in displaying alarms.

- Clears the alarm display when the cause of the alarm is no longer met (non-hold).
- Holds the alarm display until the alarm ACK operation is executed (hold).

For the procedure related to setting the alarm indication, see section 4.1.

## Alarm Output Relay (/AR1, /AR2, or /A3 option)

If you are using a model with the optional alarm output relay, a contact signal can be generated according to the alarm conditions. The following functions can be specified on the alarm output relay. For the procedure related to setting the functions, see section 4.1.

### Reflash

When multiple alarms are set to one alarm output relay, this function notifies the succeeding alarms after the first alarm that causes the relay activation. When a succeeding alarm occurs, the output relay temporarily turns OFF (approximately 500 ms). The reflash alarm function is set only to output relays I01, I02, and I03.

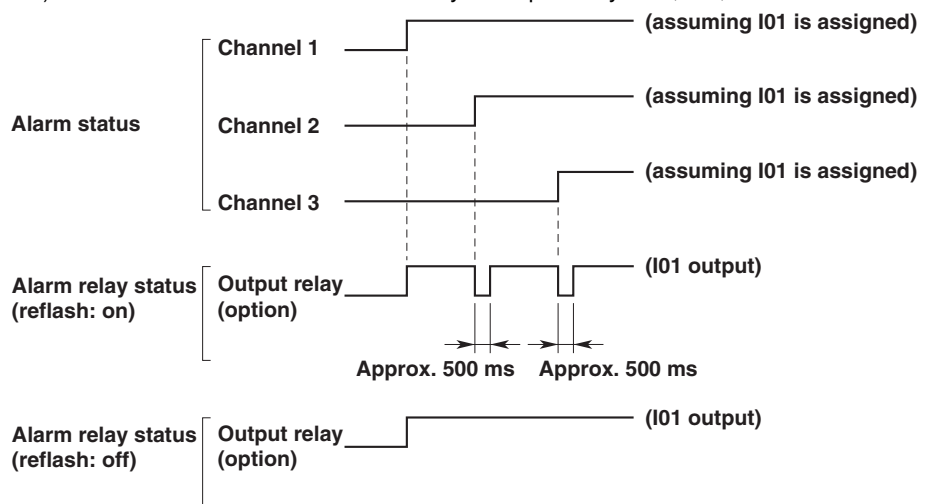

### Note

If you set the reflash alarm, relays I01 to I03 become dedicated to reflash alarms regardless of the number of alarm output relay points. Therefore, I01 to I03 operate as OR logic and non-hold regardless of the settings made in “AND/OR of alarm output relays” and “Hold/Non-hold operation of the alarm output relay” on the next page.

**AND/OR of Alarm Output Relays**

When sharing an alarm output relay among multiple alarms, you can select from the following conditions that cause the alarm output relay to be activated.

- AND: Activated when all alarms are being generated simultaneously.
- OR: Activated when at least one of the alarms is being generated.

Specify the alarm output relay to operate under the AND condition as in [I01 (first relay) to Ixx (where xx is the relay number)].

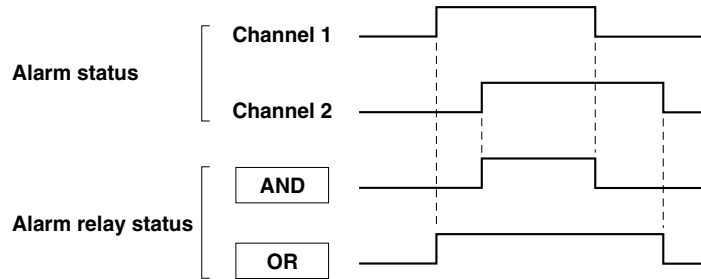

**Energize/De-energize Operation of the Alarm Output Relay**

You can select whether to energize or de-energize the alarm output relay when the alarm occurs. By selecting de-energize, the alarm output relay will operate in the same manner as when the alarm occurs when the power supply is disrupted. Energize or de-energize applies to all alarm output relays.

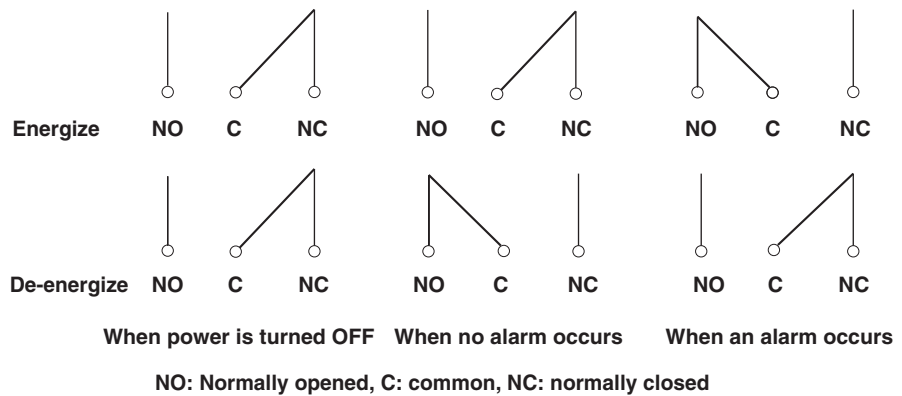

**Hold/Non-Hold Operation of the Alarm Output Relay**

There are two methods in operating the alarm output relay.

- Turns OFF the output relay when the cause of the alarm is no longer met (non-hold).
- Holds the output relay ON until the alarm acknowledge operation is executed (hold).

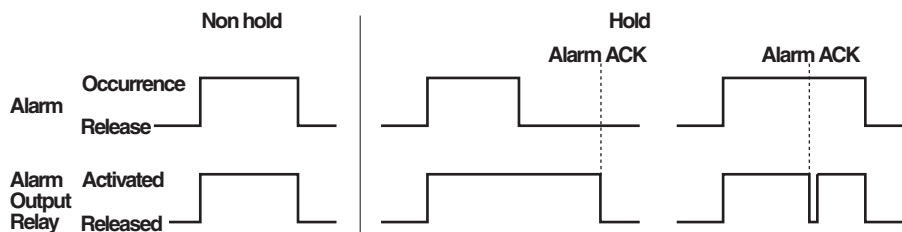

**Note**

When the system mode is entered, the activated/released condition of the previous alarm output relay is held. (Alarm detection is not carried out in the system mode, and you cannot release the alarm output relay.)



## 1.7 Computation Function and Report Function (/M1 Option)

Equations can be written to computation channels by using the measured data or computed data as variables. The result of the computation can be displayed or stored. For report functions, see page 1-48.

### Computation Channels and Execution of Equation

Number of the computation channels varies as shown in the table below. Computation is performed **at the scan interval**.

Model	Computation channels
DX102P	Channel 31 to 38 (8 channels)
DX104P	Channel 31 to 38 (8 channels)
DX106P	Channel 31 to 42 (12 channels)
DX112P	Channel 31 to 42 (12 channels)

### Types of Computations

In the table below,  $y$  represents the computed result.  $X$  and  $n$  generally represent the measured data and a constant. For details, see "Data that can be used in equations."

Type	Description
Four arithmetical operations	Addition (+), subtraction (-), multiplication ( $\times$ ), and division (/)
**	Determines the power. $y = X^n$
SQR	Determines the square root.
ABS	Determines the absolute value.
LOG	Determines the common logarithm. $y = \log_{10}X$
EXP	Determines the exponent. $y = e^X$
Relational computation	Determines $<$ , $\leq$ , $>$ , $\geq$ , $=$ , $\neq$ of two elements and outputs "0" or "1."
Logical computation	Determines the AND (logical product), OR (logical sum), XOR (exclusive logical sum) of two elements, NOT (negation) of an element and outputs "0" or "1."
TLOG computation	Determines the sum, maximum, minimum, average, and maximum – minimum (P–P) values at specified time intervals over the time interval. There are three timers used to set the time interval. For detail, see page 1-43.

### Data That Can Be Used in Equations

For TLOG computation, only measured and computed data can be used. For all other computations, all types of data can be used.

#### Measured Data

The data are specified using channel numbers in computing equations. If scaling is in effect, the scaled values are used in the computation.

#### Computed Data

The data are specified using channel numbers in computing equations.

#### Constants (K01 to K12)

The values assigned to K01 to K12 can be used as constants. Enter the values as K01 to K12 in the equations.

Range of constants (Maximum number of significant digits is 5):

$-9.9999E + 29$  to  $-1.0000E - 30$ ,  $0$ ,  $1.0000E - 30$  to  $9.9999E + 29$

#### Communication Input Data (C01 to C12)

Data that have been specified through the communication interface can be used. Enter the data as C01 to C12 in the equations. For the procedure used to set the data, see the

## 1.7 Computation Function and Report Function (/M1 Option)

DX100P/DX200P Communication Interface User's Manual (IM 04L05A01-17E).

Range of numerical values (Maximum number of significant digits is 5):

**-9.9999E + 29 to -1.0000E - 30, 0, 1.0000E - 30 to 9.9999E + 29**

### Conditions of the Remote Control Terminals (D01 to D08, /R1 option)

The conditions of the remote input signal can be assigned to "1" and "0," and used in the equations. Enter the data as D01 to D08 (the number following the letter D is the remote terminal number) in the equations.

The correlation between the conditions of the remote input signal and the value "1" and "0" are shown below.

Type of the remote input signal	Status	"1" or "0"
Contact	close	1
	open	0
Open collector	Voltage level is Lo at the remote terminal	1
	Voltage level is Hi at the remote terminal	0

### Computation Data Dropout

Computation data dropout occurs when the computation is not completed within the scan interval.

- The computation icon displayed in the status display section turns yellow (see page 1-18 and section 8.4).
- When computation data are acquired to the internal memory, the data immediately before a computation drop out are substituted for the computation data at the time of the dropout.
- When this occurs frequently, lower the CPU load by reducing the number of computation channels or making the scan interval longer.

### How to Write Equations

See section 5.18.

### Unit Handling

**The unit corresponding to the measured/computed data in the equation is not compensated.** In computations, measured and computed data are handled as values without units. For example, if the measured data from channel 01 is 20 mV and the measured data from channel 02 is 20 V, the computed result of 01 + 02 is 40.

### Order of Precedence of the Operators

The order of precedence of the operators in the equation is as follows.

Type	Operator
	(higher precedence)
Functions	ABS( ), SQR( ), LOG( ), EXP( ), TLOG.MAX( ), TLOG.MIN( ), TLOG.P-P( ), TLOG.SUM( ), TLOG.AVE( )
Power	**
Logical negation	NOT
Multiplication and division	*, /
Addition and subtraction	+, -
Greater than/less than	.GT., .LT., .GE., .LE.
Equal/not equal	.EQ., .NE.
Logical AND	AND
Logical OR, exclusive OR	OR, XOR
	(lower precedence)

### Displaying the Computed Result

The computed result of computation channels can be displayed on each operation screen. See section 1.3.

## Numerical Display

The range of displayed values of computed data is from **-9999999 to 99999999** excluding the decimal point. The decimal point position corresponds to the position of the decimal point of the upper and lower limit span of the computation channel. However, special displays are used for cases given in the table below.

Data Condition	Computation	Display
The computed result exceeds 99999999.	positive over display range	+*****
The computed result is below -9999999.	negative over display range	-*****
The value exceeds $3.4E + 38$ , or is below $-3.4E + 38$ in the middle of computation.	overflow	+***** or -*****
An error is detected. When the following computation is specified, a computation error occurs.	error	+*****
<ul style="list-style-type: none"> <li>• X/0</li> <li>• SQR (-X)</li> <li>• LOG (-X)</li> <li>• When a skipped channel No. is entered in the equation.</li> </ul>		
The number of stacks (see section 5.18) in the equation exceeds 17.	error	+*****

## Rolling Average

The moving average of the computed result of the equation specified for the computation channel is determined, and the result is displayed as computed data for that channel. The sampling interval and the number of samples can be specified for each channel. The maximum sampling interval is **1 hour**; the maximum number of samples is **64**. The initial setting is [Off] (do not perform moving average). For the setting procedure, see section 5.20.

### Note

- While the number of samples acquired is less than the specified number of samples, the average of acquired data is computed.
- The computation error data are not included in the rolling average computation.
- If the computed data exceeds the upper or lower limit, the data is clipped at the upper or lower limit, and the moving average is computed. The upper and lower limit is  $\pm 100000000$  excluding the decimal point. The decimal point position is the same as that of the specified value for the span lower limit.

## Alarm

You can set up to 4 alarms on each computation channel. The alarm types are upper limit alarm (H), lower limit alarm (L), delay upper limit alarm (T), and delay lower limit alarm (t). The hysteresis is fixed to 0. For the setting procedure, see section 5.18.

## Acquiring and Saving the Computed Data

Similar to measured data, computed data can be acquired to the internal memory as display data or event data and saved to the external storage medium (see section 1.4).

## TLOG Data

The instantaneous values of all channels (excluding measurement channels set to Skip and computation channels set to Off) can be saved at intervals specified by a timer. For a description on the saving of the TLOG data, see section 1.4. For a description on the timer operation, see the explanation in the "TLOG Computation" section on the next page. For details on the timer settings, see section 4.7.

### Note

TLOG computed data and TLOG data are not the same. TLOG computed data refers to the result of the TLOG computation. TLOG data refers to the measured/computed data of all channels acquired at specified intervals.

### TLOG Computation

Determines the sum, maximum, minimum, average, and maximum – minimum (P–P) values of the specified channel at specified time intervals. The interval is set by timers. The example shown in the following figure indicates the case in which the average value of channel 1 over each interval, TLOG.AVE(01), is determined.

Channel 31

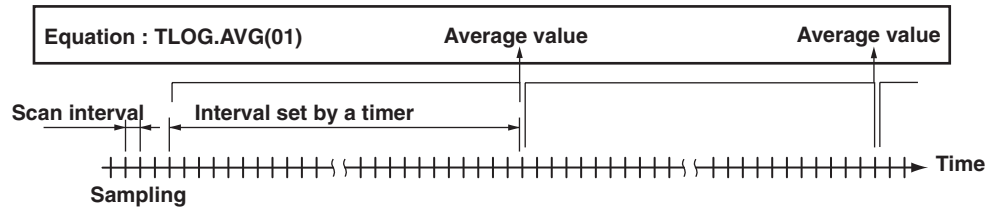

#### Timer Mode

There are two timer modes: absolute mode and relative mode.

- **Absolute Mode**

Timer expires at times determined from the reference time and the interval. The reference time is specified by the hour (00 to 23).

**Example 1:** Reference time: 14:00

Interval: 12 h

The expiration time is set to 2:00 (2:00 AM) and 14:00 (2:00 PM).

**Example 2:** Reference time: 00:00

Interval: 10 min

The expiration time is set to 0:00, 0:10, 0:20, ..., 23:40, and 23:50. For example, if the computation is started at 9:36, the time expiration will occur at 09:40, 09:50, 10:00, and so on.

- **Relative Mode**

The timer is started when the computation is started. The timer is repeated at each interval. The timer is suspended while the power is lost.

**Example:** Interval: 00:15

The timer expires every 15 minutes after the computation is started.

For the procedure related to setting the timer type and the interval, see section 4.7. For the procedure related to setting the timer to be used, see section 5.19.

#### Sum Scale of the TLOG.SUM

In the sum computation (TLOG.SUM) of time series, data are summed over the scan interval. However, for flow values that have units /s, /min, or /h, a simple summation results in the actual value not matching the computed result, because the scan interval and the unit of the input values are different. In these cases, the unit of the data measured over the scan interval is converted to match the unit of the input values and the computation is performed.

For example, if the scan interval is 2 s, and the input value is 100 m<sup>3</sup>/min, a simple summation would add 100 every 2 s resulting in 3000 after one minute. However, if the computing unit is set to /min, then 2 s/60 s is multiplied every scan interval before the value is added giving a result that has a m<sup>3</sup>/min unit. The following equations are applied. The scan interval unit is in seconds.

Off  $\sum(\text{measured value})$

/s  $\sum(\text{measured value}) \times \text{scan interval}$

/min  $\sum(\text{measured value}) \times \text{scan interval}/60$

/h  $\sum(\text{measured value}) \times \text{scan interval}/3600$

For the setting procedure, see section 5.19.

**Reset Action**

Whether or not to reset the computed result at every timeout is selectable. The figure below shows the action of TLOG.SUM computation.

**Example:** Result of the TLOG.SUM computation

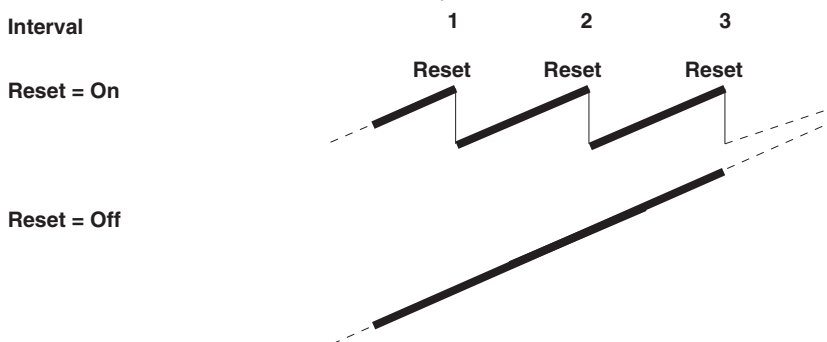

The summed value is reset to “0” at every interval when “Reset” is “On,” or the summed value from the start of computation is derived when “Reset” is “Off.”

**If Power is Lost While the TLOG Computation Was in Progress**

The TLOG computation is resumed when the power is restored. The operation varies depending on whether power is restored before or after the scheduled time to create the TLOG data.

Time of Recovery	TLOG Computation Operation
After the time to create the TLOG data	TLOG data are created immediately when power is restored. The measured/computed data up to the time of the power disruption are used. At the next scheduled TLOG computation time, data will be used from the point in time after the power was restored.
Before the time to create the TLOG data	After power is restored, TLOG data are created at the normally scheduled time to perform the TLOG computation. All measured/computed data excluding the power disruption period are used.

**How the Measured/Computed Data are Handled When There is an Abnormality in the Data**

Type of Abnormal Data	Report Data		
	AVE	MAX/MIN/P-P	SUM
Positive over*	not used	used	not used
Negative over*	not used	used	not used
Error	not used	not used	not used

\* “over range” for measurement channels or “computation overflow” for computation channels

### Report Function

This function is used to create hourly, daily, weekly, and monthly reports. The report data can be displayed on the screen. The report data are saved to the external storage medium in ASCII format. For data formats, see appendix 2, "Data Formats of ASCII Files." For the setting procedure, see section 4.6.

#### Types of Reports

- **Hourly Report**

On every hour on the hour, the average, maximum, minimum, and sum values of the specified channels are determined from an hour of data up to the current hour and stored to the internal memory.

- **Daily Report**

At the specified time everyday, the average, maximum, minimum, and sum values of the specified channels are determined from a day of data up to the specified time and stored to the internal memory.

- **Weekly Report**

At the specified time of the specified day every week, the average, maximum, minimum, and sum values of the specified channels are determined from a week of data up to the specified time and stored to the internal memory.

- **Monthly Report**

At the specified time of the specified date every month, the average, maximum, minimum, and sum values of the specified channels are determined from a month of data up to the specified time and stored to the internal memory.

#### Report Data Display

For a display example of report data, see section 1.3.

#### Combinations of Reports That Can be Created

The reports created by the DX100P can be set to "hourly only," "daily only," "hourly and daily," "daily and weekly," or "daily and monthly."

#### Number of Measurement and Computation Channels That Can Be Assigned to the Report

Up to 12 channels can be assigned to one report.

The report data are not created for channels that are set to Skip or those that have the computation turned Off.

#### About the Sum Scale

In the sum computation, data are summed over the scan interval. However, for flow values that have units /s, /min, /h, or /day a simple summation results in the actual value not matching the computed result, because the scan interval and the unit of the input values are different. In these cases, the unit of the data measured over the scan interval is converted to match the unit of the input values and the computation is performed.

## 1.7 Computation Function and Report Function (/M1 Option)

For example, if the scan interval is 2 s, and the input value is 100 m<sup>3</sup>/min, a simple summation would add 100 every 2 s resulting in 3000 after one minute. However, if the sum unit is set to /min, then 2 s/60 s is multiplied every scan interval before the value is added giving a result that has a m<sup>3</sup>/min unit. The following equations are applied. The scan interval unit is in seconds.

- Off      $\Sigma(\text{measured value})$
- /s      $\Sigma(\text{measured value}) \times \text{scan interval}$
- /min    $\Sigma(\text{measured value}) \times \text{scan interval}/60$
- /h      $\Sigma(\text{measured value}) \times \text{scan interval}/3600$
- /day    $\Sigma(\text{measured value}) \times \text{scan interval}/86400$

### If Power is Lost While the Report Function is in Progress

If a power disruption occurred while the report function was in progress, the report function will resume after the power is restored. The exact operation will vary depending on whether the power is restored before or after the scheduled time to create a report.

Time of Recovery	Report Operation
After the time to create the report	Report data are created immediately after power is restored. The measured/computed data up to the time of the power disruption are used. For the next scheduled report, data after the power recovery are used.
Before the time to create the report	After power is restored, report data are created at the time of the next normally scheduled report. All measured/computed data excluding the power disruption period are used.

### How the Measured/Computed Data Are Handled When There is an Abnormality in the Data

Type of Abnormal Data	Report Data		
	Average value	Maximum/Minimum value	Sum value
Positive over*	not used	used	not used
Negative over*	not used	used	not used
Error	not used	not used	not used

\* "over range" for measurement channels or "computation overflow" for computation channels

### Displaying the Report

The reports can be displayed using the key operations. For the operating procedure, see section 7.4.

- **Status Display**

If the data of a measurement or a computation channel enter any of the conditions listed below within the relevant time period (one hour for hourly reports for example), a symbol that indicates the condition is output to the report.

Data Condition	Symbol
<b>Common to measurement and computation channels</b>	
Measurement error or computation error	E
<b>For measurement channels</b>	
Positive (+) over range (See page 1-10)	O
Negative (-) over range (See page 1-10)	O
<b>For computation channels</b>	
Positive (+) computation overflow (when the value exceeds 3.4E + 38)	O
Negative (-) computation overflow (when the value falls below -3.4E + 38)	O
<b>Power failure/Time change</b>	
Power failure	P
Time change	C

## 1.7 Computation Function and Report Function (/M1 Option)

### Numerical Display

The range of displayed values of report data is from **-9999999** to **99999999** excluding the decimal point. The decimal point position corresponds to the position of the decimal point of the lower limit span of the computation channel.

However, special displays are used for cases given in the table below.

#### • Measurement Channel

Item	Data Condition of Measurement Channels	Displayed value
AVE (Average value)	When all data are measurement errors or over range	(Blank)
MAX, MIN (Maximum value, minimum value)	<ul style="list-style-type: none"> <li>• When all data are measurement errors</li> <li>• Positive (+) over range</li> <li>• Negative (-) over range</li> </ul>	(Blank) 99999 -99999
SUM (Sum value)	<ul style="list-style-type: none"> <li>• When all data are measurement errors or over range</li> <li>• When the sum value exceeds <math>3.4E + 38</math></li> <li>• When the sum value is below <math>-3.4E + 38</math></li> </ul>	(Blank) $9.999999E + 99$ $-9.999999E + 99$

#### • Computation Channel

Item	Data Condition of Computation Channels	Displayed value
AVE (Average value)	When all data are computation errors or over range	(Blank)
MAX, MIN (Maximum value, minimum value)	<ul style="list-style-type: none"> <li>• When all data are computation errors</li> <li>• When the maximum value exceeds 99999999</li> <li>• When the minimum value is below -9999999</li> </ul>	(Blank) 99999999 -99999999
<p>The decimal position that was specified when the span for the channel was specified is reflected in the maximum and minimum values. For example, if the span setting of the channel is "200.0," then "99999999" is output when the value exceeds "99999999.9" and "-99999999" is output when the value is below "-999999.9."</p>		
SUM (Sum value)	<ul style="list-style-type: none"> <li>• When all data are computation errors or computation overflow</li> <li>• When the sum value exceeds <math>3.4E + 38</math></li> <li>• When the sum value is below <math>-3.4E + 38</math></li> </ul>	(Blank) $9.999999E + 99$ $-9.999999E + 99$

### Storing to the Internal Memory and Saving to the External Storage Medium

For the description, see section 1.4.



## 1.8 FAIL/Memory End Output Function (/F1 option)

FAIL output, memory end output, or Memory Start/Memory Stop output can be assigned to the two output relays. For the procedure, see section 4.8.

### FAIL Output

When a failure occurs in the CPU of the DX100P, the relay contact signal (1 signal) is output.

The relay is energized when the CPU is normal; it is de-energized when a CPU failure occurs (de-energized on failure). Therefore, relay output is carried out even when the power is turned OFF (even during a power failure) (see figure below). You cannot change this behavior.

- **FAIL relay output (de-energized on failure)**

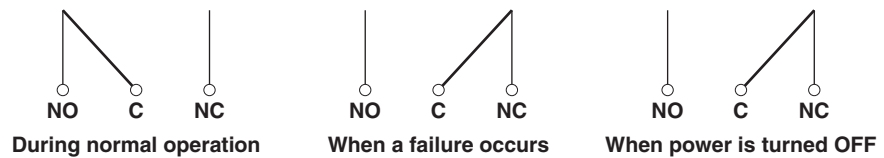

\* NO, C, and NC are names of the relay output terminals.  
NO: Normally Opened, C: Common, NC: Normally Closed

### Memory End Output

The relay is energized when either of the following conditions is met. You cannot change this behavior.

- When the remaining free space on the external storage medium is less than equal to 10% or 6 MB (when the storage area is not used cyclically (Media FIFO))  
When an external storage medium error is detected (when the storage area is used cyclically (Media FIFO))
- When the remaining amount of time of the internal memory (time until overwriting starts) is less than or equal to the specified time (memory alarm time) if an external storage medium is not inserted in the drive

For details on setting the memory alarm time, see section 4.9.

- **Relay Operation**

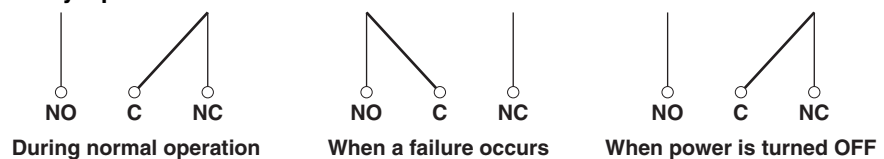

### Memory Start/Stop Output

The relay is energized when Memory Start operation is executed and is de-energized when Memory Stop operation is executed. You cannot change this behavior.

- **Relay Operation**



## 1.8 FAIL/Memory End Output Function (/F1 option)

---

### Outputting the User Locked Condition

If a wrong password is entered three consecutive times when logging in or signing, the user is locked. At this point, the relay is energized. When the operation of acknowledging the user lock (see section 6.1) is executed, the relay is de-energized. You cannot change this behavior.

- **Relay Operation**

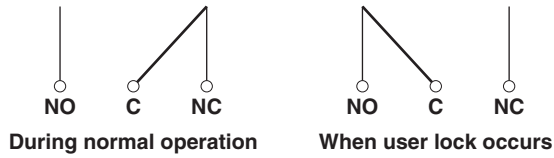

### Outputting the Presence of Login Users

The relay is energized when there is a user\* logged into the DX100P. Otherwise, the relay is de-energized. You cannot change this behavior.

\* Login using keys and login to the setting function via the Ethernet or serial interface.

- **Relay Operation**

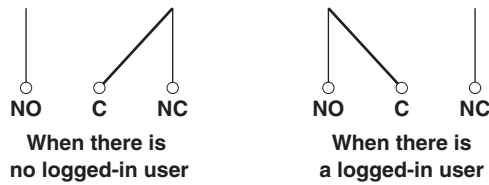

## 1.9 Remote Control Function (/R1 Option)

When a contact or open collector signal is applied to the remote control terminal, a predetermined action is carried out.

Arbitrary actions can be assigned to the eight remote control terminals.

For the setting procedure, see section 4.5.



### Actions That Can Be Assigned

Enclosed in parentheses are soft key expressions.

- **None: [None]**  
No action is assigned.
- **Memory Start/Memory Stop: [StartStop]**
  - Remote input: Edge (Rising/start, falling/stop)
  - Executes Memory Start and Memory Stop.
  - After Memory Start is executed, applying a rising signal produces no effect. After Memory Stop is executed, applying a falling signal produces no effect.
- **Acknowledge alarms: [AlarmACK]**
  - Remote input: Trigger, 250 ms or more
  - Acknowledges all alarms.
- **Adjusting the Internal Clock: [Time adj]**
  - Remote input: Trigger, 250 ms or more
  - Adjusts the internal clock of the DX100P to the nearest hour depending on the time when the remote signal is applied.

#### Operation when data acquisition is stopped

Time of signal input	New time
00 min. 00 s to 01 min. 59 s	Adjusts the internal clock down to the nearest hour. Example: 10 hr. 01 min. 50 s becomes 10 hr. 00 min. 00 s.
02 min. 00 s to 57 min. 59 s	Time is unchanged.
58 min. 00 s to 59 min. 59 s	Adjusts the internal clock down to the nearest hour. Example: 10 hr. 59 min. 50 s becomes 11 hr. 00 min. 00 s.

#### Operation when data acquisition is in progress

If the signal input time is within the specified time deviation from the nearest hour, the time is gradually corrected. Otherwise, the time is not corrected. For details on the behavior, see section 1.10.

- **Starts/Stops Computation (option): [Math]**
  - Remote input: Edge (Rising/start, falling/stop)
  - Starts/stops the computation. This is valid only on models with the computation function (/M1 option).
  - If the computation is started, applying a rising signal produces no effect. If the computation is stopped, applying a falling signal produces no effect.

## 1.9 Remote Control Function (/R1 Option)

---

- **Clears Computed Results (option): [Math rst]**
  - Remote input: Trigger, 250 ms or more
  - Resets the data on all computation channels. This is valid only on models with the computation function (/M1 option) and while the computation is stopped. For all other cases, applying the remote signal produces no effect.
- **Manual Sampling: [M.sample]**
  - Remote input: Trigger, 250 ms or more
  - The instantaneous values of all measurement and computation channels (excluding the measurement channels that are set to [Skip] and the computation channels that are turned Off) can be stored to the internal memory.
- **Writing Messages: [Message1] to [Message8]**
  - Remote input: Trigger, 250 ms or more
  - Displays a message at the position corresponding to the time when the signal was applied on the trend screen. [Message1] to [Message8] correspond to messages 1 to 8 of the message group 7. The displayed message is also written to the internal memory. When the data acquisition to the internal memory is stopped, messages cannot be displayed or written. Applying a remote signal produces no effect.
- **Snap Shot: [Snapshot]**
  - Remote input signal: Trigger, 250 ms or more
  - Saves the current screen image data to the external storage medium. The snapshot function operates in all modes (operation mode, engineering mode, and system mode). Error messages, even if they are displayed, are not saved.

### Remote Input Signal

The above operations are carried out on the rising or falling edge of the remote signal (edge) or the ON signal lasting at least 250 ms (trigger).

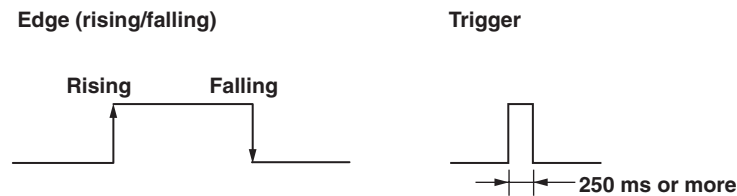

For contact inputs, the remote signal rises when the contact switches from open to closed and falls when the contact switches from closed to open. For open collector signals, the remote signal rises when the collector signal (voltage level of the remote terminal) goes from high to low and falls when the collector signal goes low to high.

## 1.10 Other Functions

### USER key

One of the following actions can be assigned to the USER key. For the setting and operating procedure, see section 5.8, and chapter 8, respectively.

#### Actions That Can Be Assigned

Name of Action	Action
None	None
AlarmACK	Release alarm indication and relay output (when alarm display and alarm output relay action is set to "hold." ⇒"Section 4.1")
Math	Starts/stops computation (when the computation function (/M1) is equipped). ⇒"Section 8.4"
Math rst	Clears computed results (when the computation function (/M1) is equipped and the computation is suspended). ⇒"Section 8.4"
M.sample	Stores instantaneous values of all channels to the internal memory. ⇒"Section 8.3"
Message 1 to Message 8	Displays messages and stores them to the internal memory. ⇒"Section 8.2"
Snapshot	Saves the screen image data to the external storage medium. ⇒"Section 8.5"

#### Note

If you log in as a user that is not allowed to perform action assigned to the USER key, the action is not executed when you press the USER key.

### Log Display

A list of phenomena that occurred can be displayed in the order of occurrence for the following items:

- A log of operations (2000 most recent operations)
- A log of setting changes (200 most recent setting changes)
- Error messages (50 most recent messages)
- A log of communication commands (200 most recent commands)
- A log of file transfers using the FTP client function (50 most recent transfers)
- A log of e-mail transmissions (the 50 most recent transmissions)
- A log of Web operations (the 50 most recent operations)
- A log of access to the SNTP server (the 50 most recent operations)

For details related to the display format, see section 8.9.

#### Error Log Example

The number of the log displayed on the last line

Total number of logs

(012/050)	Time	No.	Message
Nov.19.2001	10:50:18	111	The login user ID is inc..
Nov.19.2001	10:48:08	612	Please acknowledge all a..
Nov.19.2001	10:13:30	089	Press [FUNC] key to logi..
Nov.19.2001	10:13:02	601	Measured data have been ..
Nov.19.2001	10:12:30	613	You can't sign this reco..
Nov.19.2001	07:15:51	245	This function cannot be ..
Nov.19.2001	07:15:05	152	This action is not possi..
Nov.19.2001	07:14:50	210	Media has not been inser..
Nov.19.2001	07:08:46	152	This action is not possi..
Nov.19.2001	07:08:46	152	This action is not possi..
Nov.19.2001	07:07:50	612	Please acknowledge all a..
Nov.19.2001	07:07:46	612	Please acknowledge all a..

Error message

Error code (see chapter 9)

Date and time of occurrence

**Time Change Function**

The time of the DX100P internal clock can be changed using keys, remote control function (/R1 option), or SNTP client function.

- **Key Operation**  
The DX100P internal clock is set to the specified time.
- **Remote Control Function**  
The DX100P internal clock is adjusted to the nearest hour. See section 1.9.
- **SNTP Client Function**  
The DX100P internal clock is set to the time retrieved from an SNTP server.

The time correction operation varies depending on whether data acquisition is progress on the DX100P.

- **When Data Acquisition Is Stopped**  
The time of the DX100P internal clock is changed immediately.
- **When Data Acquisition Is in Progress**  
The time of the DX100P internal clock is gradually corrected. While the time is being gradually adjusted, the date/time in the status display section is displayed in yellow (see page 1-18).

**Note**

**Operation of gradually correcting the time of the internal clock**

If the time deviation between the time of the DX100P internal clock and the correct time (the specified time) is within a specified value, the time on the DX100P is adjusted by 1/64 s for each second. Otherwise, the time is not corrected. The maximum value of time deviation for changing the time ( $t_m$  in the figure below) can be selected in the range of 10 s to 5 min.

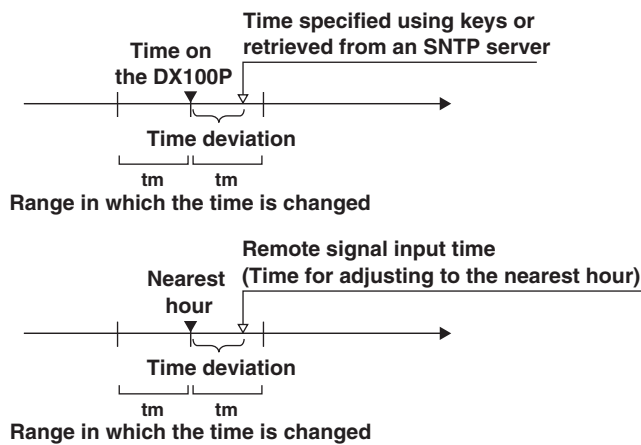

**Example:** When changing the time to 12 hours 55 minutes 35 seconds when the internal clock is 12 hours 55 minutes 32 seconds  
The time deviation of 3 seconds is adjusted by 1/64 s for each second. The internal clock will be set to the correct time 192 seconds later.

## System Screen

The total number of inputs on the DX100P, the capacity of the internal memory, the communication functions, the external storage medium drive, the options, the MAC address, and the firmware version number can be displayed. For the operating procedure, see section 8.9.

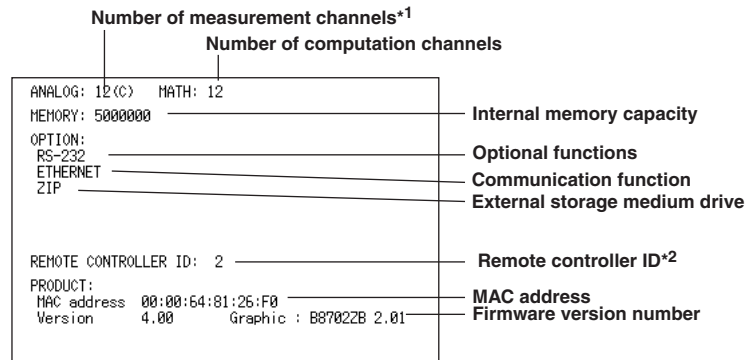

\*1 When the cramped input terminal is equipped (/H2 option), "C" is indicated as "ANALOG: 8(C)" in this example.

\*2 Displayed when the easy text entry is equipped (/KB1 and /KB2 options).

## Displayed Language

The displayed language can be selected from English, Japanese, German, or French. For the setting procedure, see section 4.9.

## Daylight Savings Time

The DX100P time can be adjusted automatically to Daylight Savings Time if the DX100P is used in a region in which the time is set ahead by 1 hour during the summer season.

- The start and end times of DST are specified as in "12th hour on the first Sunday of June."

The DX100P automatically sets the time ahead by 1 hour at the start time every year. The DX100P automatically sets the time back by 1 hour at the end time.

**Example:** If the DST start time is set to "2nd hour on the first Sunday in April," the time on the DX100P is set to "3rd hour" at that time.

**Example:** If the DST end time is set to "1st hour on the last Sunday in October," the time on the DX100P is set to "0 hour" at that time.

- The start and end of DST are recorded in the operation log.

For the setting procedure, see section 5.21.

## Temperature Unit

The temperature unit can be set to Celsius (°C) or Fahrenheit (°F). This applies to all channels. For the setting procedure, see section 4.2.

### 24 VDC Power Supply for Transmitter (/TPS2, /TPS4 option)

Provides 24 VDC power to up to two (/TPS2) or four (/TPS4) transmitters. As the output from the transmitter is a 4 to 20 mA signal on the same cable as for power supply, the cable is connected to the input terminal of the DX100P and displayed on the DX100P's screen. For the terminal arrangement, see section 2.9.

### Snap Shot (Saving the Screen Image Data)

The image data displayed on the screen can be saved to the external storage medium through key operation. The data is in PNG format and can be pasted to commercially sold software programs such as document creation software. For the operating procedure, see section 8.5.

### Easy Text Entry (/KB1, /KB2 Option)

You can control the DX100P using the keys on the remote control terminal.

- Set the remote controller ID on the DX100P and the ID number on the remote control terminal to the same value.
- You can set a value between 0 and 31 for the remote controller ID and ID number. For the setting procedure, see section 4.9.

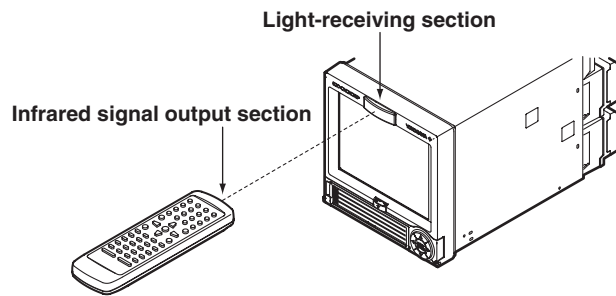

---

#### Note

- The remote control terminal can be used to control both the DX100P and the DX200P.
  - Using a single remote control terminal, you can control DX100Ps or DX200Ps with different remote controller IDs by changing the ID number on the remote control terminal.
-



## 2.1 Precautions on the Use of the DX100P

Read the following precautions before using the DX100P and the external storage medium (Zip disk, flash memory card).

### Handling Precautions

- Use care when cleaning the DX100P, especially any plastic parts. When cleaning, wipe with a dry, soft cloth. Do not use chemicals such as benzene or thinner, since these may cause discoloring and deformation.
- Keep electrically charged objects away from the DX100P as this may cause malfunction.
- Do not apply volatile chemicals to the LCD monitor or panel keys. Do not allow rubber and vinyl products to remain in contact with the DX100P for long periods of time. This may damage the DX100P.
- Do not apply shock to the DX100P.
- When not in use, make sure to turn OFF the power switch.
- If there are any symptoms of trouble such as strange odors or smoke coming from the DX100P, immediately turn OFF the power and unplug the power cord. Then, contact your nearest YOKOGAWA dealer.

---

### **CAUTION**

Don't put any weight on the DX100P while it is in reclined position with its front feet up, as it may damage the feet.

---

### Handling Precautions of External Storage Media

- Take special care in handling external storage media as they are delicate products. For general precautions, see the instruction manual that came with the external storage medium.
- Zip disks may not operate properly under high or low temperature environment. Use the DX100P in the specified temperature range.
- Remove the external storage medium from the drive when turning ON/OFF the DX100P.
- Do not remove the external storage medium while the access lamp is lit. Doing so can destroy the data on the medium.
- It is recommended to keep a duplication of the saved data on the external storage medium.
- If you are using a commercially available compact flash card on DX100Ps in the ATA flash memory card drive, be careful of static electricity. The DX100P may not operate properly if you touch the compact flash card that is inserted into the DX100P when your body is charged with static electricity.
- Handling the CF Card and Adapter  
Insert the CF card into the adapter as shown in the figure below. The card should remain in the adapter when removing it from the card slot on the DX100P.

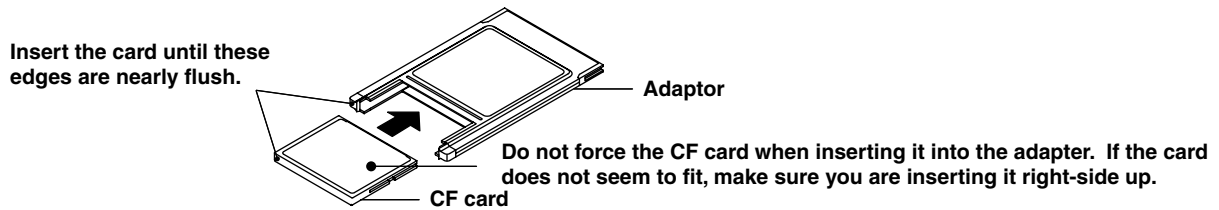

---

### CAUTION

Don't expose the Zip drive to vibration or shocks, as it may damage the drive.

---

## 2.2 Names of Parts and Functions

### Front Panel

Light-receiving section for the infrared signal from the remote control terminal  
(valid only on models with the /KB1 or /KB2 option)

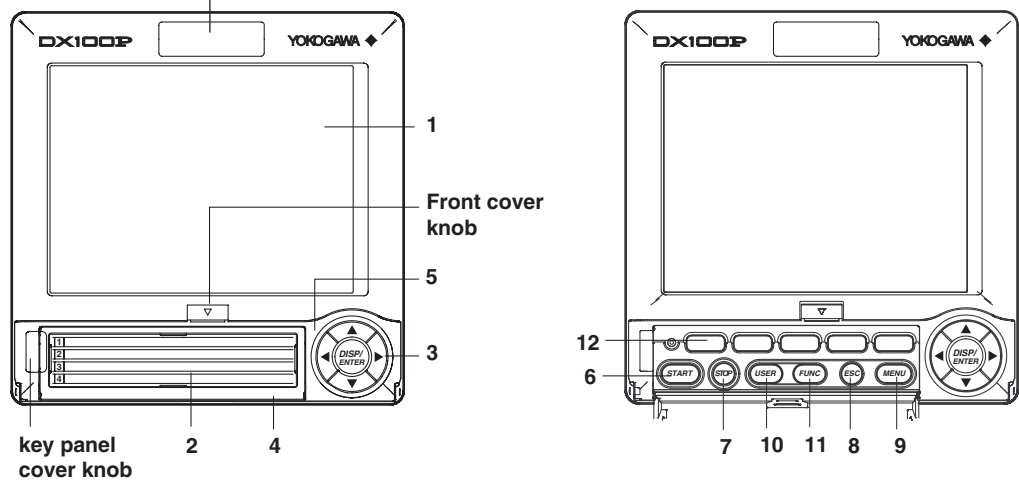

key panel  
cover knob

#### 1. LCD screen

Displays various operation screens such as the trend screen and the setup screen to configure the DX100P.

#### 2. Label

A label used to distinguish the channels. Write on this label and use it as a reference.

#### 3. Operation key

Left, right, up, and down arrow keys and the DISP/ENTER key. The keys are used to switch the operation screen in the operation mode. In the setup screens, the keys are used to select parameters and to confirm the new settings.

#### 4. Key panel cover

Open this cover to access the keys besides the arrow keys and the DISP/ENTER key. Open the cover by pulling the tab on the upper left corner of the cover toward you.

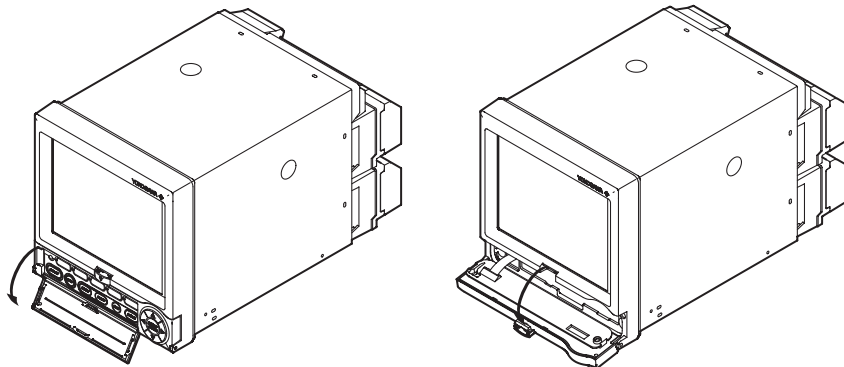

#### 5. Front cover

Open the front cover when turning ON/OFF the DX100P or inserting or removing the external storage medium. Open the cover by pushing down on the tab located at the center of the top edge of the cover and pulling it forward. Keep the cover closed at all times except when accessing the power switch and the external storage medium.

#### Note

For DX100Ps which are side-by-side mounted vertically, when a front panel is opened the down arrow key may interfere the upper front panel.

## 2.2 Names of Parts and Functions

### 6. **START key**

Press this key to execute Memory Start. The data acquisition to the internal memory starts, and the waveform is displayed on the trend screen. If the model has the optional computation function (/M1), computation and report also starts simultaneously.

### 7. **STOP key**

Press this key to execute Memory Stop. The data acquisition to the internal memory stops. The updating of the waveform on the trend display also stops. If the model has the optional computation function (/M1), the report is stopped.

### 8. **ESC key**

Used to cancel an operation. Also used to return to the menu screen from the setting screens.

### 9. **MENU key**

Used to enter the engineering mode from the operation mode.

### 10. **USER key**

Executes the action assigned to this key. For the procedure related to assigning actions, see section 5.8.

### 11. **FUNC key**

Used to execute various functions in the operation mode. For the functions that you can execute, see section 3.4.

### 12. **Soft keys**

Pressing the FUNC key displays a function name that is assigned to the soft keys at the bottom of the screen. The soft key can be used to carry out the assigned function.

In addition, selections are assigned to the soft keys in the engineering or system mode at the bottom of the screen. In this case, you can press the soft key to select the assigned selection.

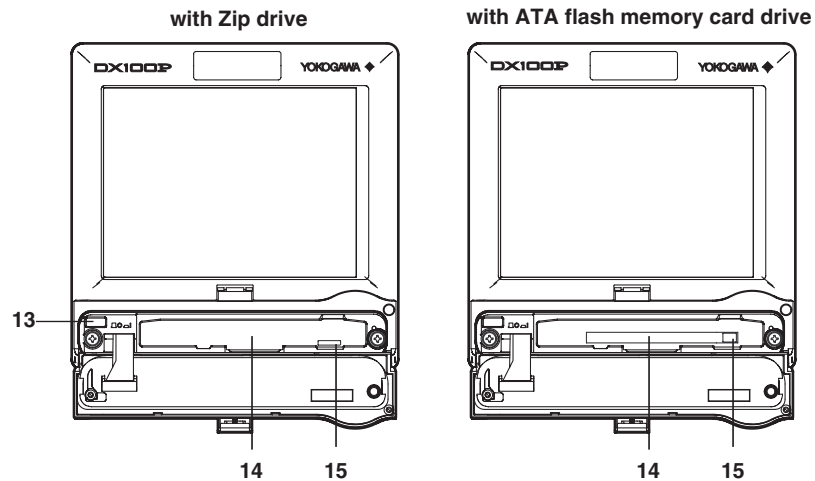

### 13. **Power switch**

### 14. **Storage medium drive**

Zip drive or ATA flash memory card drive depending on the specification.

### 15. **Eject button (Access indicator for Zip drive)**

Used when ejecting the storage medium. Also is the access indicator for the Zip drive. The access indicator is lit while the Zip disk is being accessed.

Rear Panel

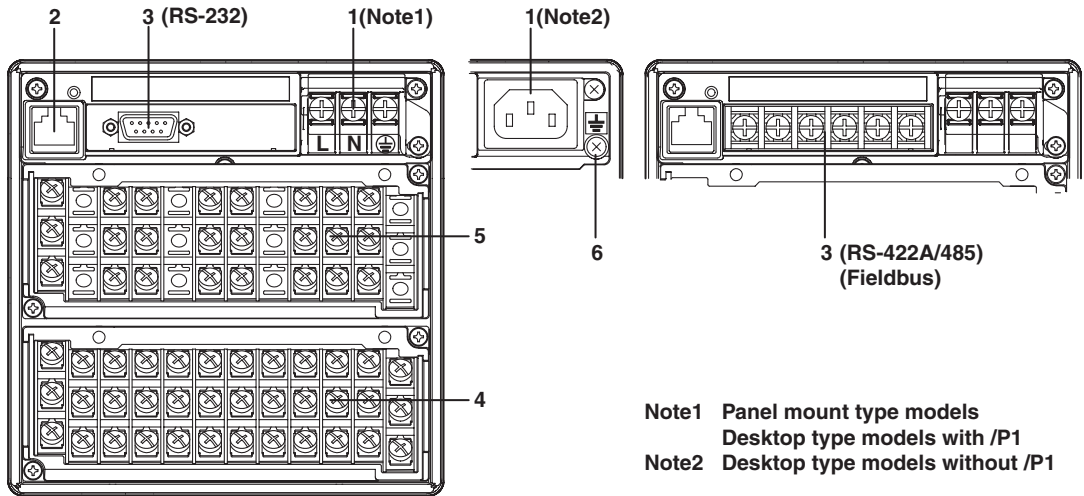

1. **Power terminals and a protective ground terminal**  
Connect the power cord and the protective ground cord.
2. **Ethernet port**  
Connect the Ethernet cable (10Base-T).
3. **Serial interface port (/C2, /C3 option)**  
RS-232 port or RS-422A/485 port depending on the specification. Connect the interface cable.
4. **Input terminals**  
Connect the input signal cable of the item being measured.
5. **Option terminals (/AR1, /AR2, /A3, /F1, /R1, /TPS2, /TPS4 option)**  
Connect optional input/output signal cables.
6. **Functional ground terminal**

**Note** See the DX100P/DX200P Communication interface user's manual (IM 04L05A01-17E) to use Ethernet port and the serial interface port.

Desktop Type

1. **Carrying handle**
2. **Foot (four) and folding stand (two)**

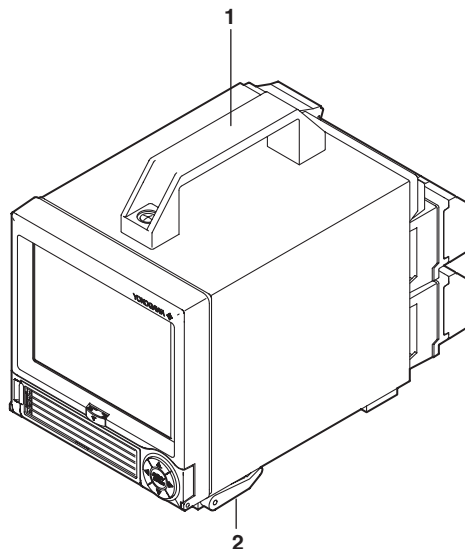

**2** Before Using the DX100P

---

## 2.3 Installing the DX100P

### Installation Location

Install the DX100P indoors, in a location that meets the following conditions. See also the normal operating conditions described in section 11.8, “General Specifications.”

- **Instrument panel**  
The DX100P is designed for panel mounting.
- **Well-ventilated location**  
To prevent overheating, install the DX100P in a well-ventilated location. For the panel mount type, see “Panel Cutout” in section 11.9, “Dimensional Drawings.”  
For the desktop type, a space of **50 mm** or more from the right, left and top surface of the DX100P is recommended.
- **Minimum mechanical vibrations**  
Choose an installation location with the minimum mechanical vibration.
- **Horizontal**  
Install the DX100P horizontally (However, the DX100P can be inclined up to 30 degrees backwards for panel mounting).

---

#### Note

- Condensation may occur if the DX100P is moved to another place where both the ambient temperature and humidity are higher, or if the temperature changes rapidly. In addition, measurement errors will result when using thermocouples. In this case, let the DX100P adjust to the new environment for at least one hour before using it.
  - The lifetime of the LCD may be shortened if the DX100P is used in a high-temperature environment over a long period of time. It is recommended that the backlight brightness of the LCD be set low when the DX100P is installed in a relatively hot environment (40°C or higher). For setting the LCD brightness, see section 5.14.
- 

Do not install the DX100P in the following places:

- **Outdoors**
- **In direct sunlight or near heat sources**  
Install the DX100P in a place with small temperature fluctuations near room temperature (23°C). Placing the DX100P in direct sunlight or near heat sources can cause adverse effects on the internal circuitry.
- **Where an excessive amount of soot, steam, moisture, dust, or corrosive gases are present**  
Soot, steam, moisture, dust, and corrosive gases will adversely affect the DX100P. Avoid such locations.
- **Near strong magnetic field sources**  
Do not bring magnets or instruments that produce electromagnetic fields close to the DX100P. Operating the DX100P in strong magnetic fields can cause errors in the measurements.
- **Bad angle for viewing the screen**  
Because the DX100P uses a 5.5” TFT color LCD, it is difficult to view the display from an extreme angle. Please install the DX100P so that the monitor can be viewed from the front.

### Installation Procedure (Panel Mount Type)

The DX100P should be mounted on a steel panel of thickness 2 mm to 26 mm.

1. Insert the DX100P from the front side of the panel.
2. As shown in the figure below, mount the DX100P to the panel using the mounting brackets that came with the package.
  - Use two brackets to support the top and bottom or the left and right sides of the case. (Remove the seal that is covering the holes for the mounting brackets beforehand.)
  - The proper torque for tightening the mounting screws is 0.8 to 1.2 Nm.

### CAUTION

Tightening the screws too much can deform the case or damage the bracket.

#### Panel Mounting

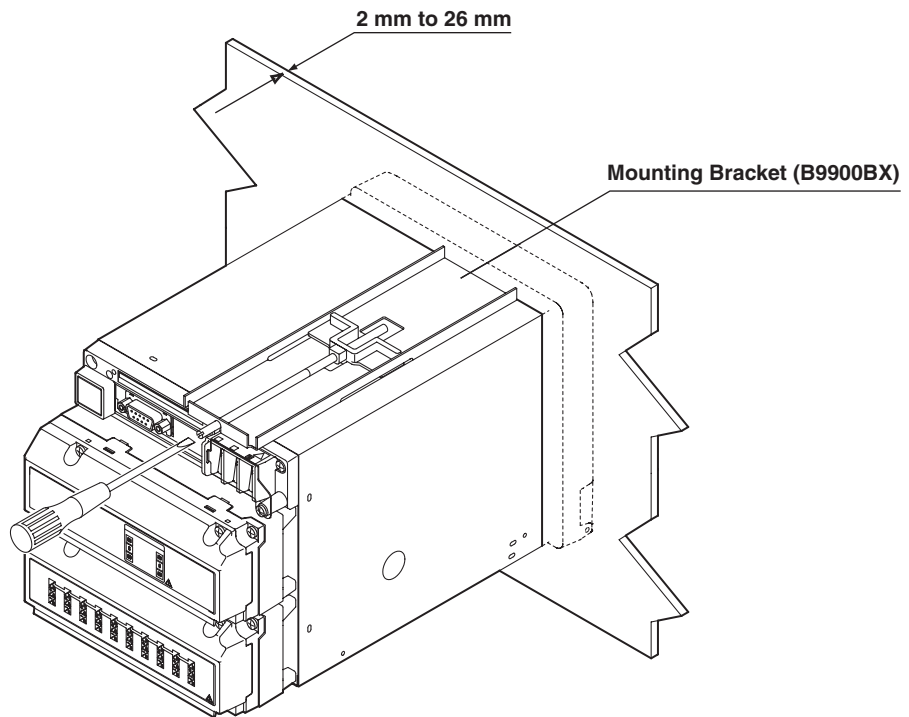

For panel cutout and external dimensions, see section 11.9, "External Dimensions."

## 2.4 Input Signal Wiring



### CAUTION

- If a strong tension is applied to the cable wired to the DX100P, the terminals of the DX100P and/or the cable can be damaged. In order to prevent tension from being applied directly on the terminals, fasten all wiring cables to the rear of the mounting panel.
- To prevent fire, use signal wires having a temperature rating of 70°C or more.

### Precautions to Be Taken While Wiring

Take the following precautions when wiring the input signal cables.

- **It is recommended that crimp-on lugs (designed for 4 mm screws) with insulation sleeves be used on the lead wire ends. However, this does not apply to the optional clamped terminals (optional code /H2).**

Crimp-on lug

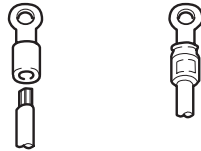

- **For clamped input terminals (/H2), the following wires are recommended.**  
**Cross sectional area of the conductor or conductors**
  - Single conductor: 0.14 mm<sup>2</sup> to 1.5 mm<sup>2</sup>
  - Stranded conductors: 0.14 mm<sup>2</sup> to 1.0 mm<sup>2</sup>
  - Stripped cable length: approximately 5 mm
- **Take measures to prevent noise from entering the measurement circuit.**
  - Move the measurement circuit away from the power cable (power circuit) and ground cable.
  - It is desirable that the item being measured does not generate noise. However, if this is unavoidable, isolate the measurement circuit from the item. Also, ground the item being measured.
  - Shielded wires should be used to minimize noise caused by electrostatic induction. Connect the shield to the ground terminal of the DX100P as necessary (make sure you are not grounding at two points).
  - To minimize noise caused by electromagnetic induction, twist the measurement circuit wires at short, equal intervals.
  - Make sure to earth ground the protective ground terminal through minimum resistance (less than 100 Ω).
- **When using internal reference junction compensation on the thermocouple input, take measures to stabilize the temperature at the input terminal.**
  - Always use the input terminal cover.
  - Do not use thick wires which may cause large heat dissipation (cross sectional area 0.5 mm<sup>2</sup> or less recommended).
  - Make sure that the ambient temperature remains reasonably stable. Large temperature fluctuations can occur if a nearby fan turns ON or OFF.
- **Connecting the input wires in parallel with other devices can cause signal degradation, affecting all connected devices.**

If you need to make a parallel connection, then

  - Turn the burnout function OFF. (See section 4.2)
  - Ground the instruments to the same point.
  - Do not turn ON or OFF another instrument during operation. This can have adverse effects on the other instruments.
  - RTDs cannot be wired in parallel.



**WARNING**

To prevent electric shock, ensure the main power supply is turned OFF.

**CAUTION**

- Do not apply input signals that exceed the following values. This can damage the DX100P.
  - Maximum input voltage
    - Voltage range of 2 VDC or less or thermocouples:  $\pm 10$  VDC
    - Voltage range between 6 and 50 VDC:  $\pm 60$  VDC
  - Maximum common mode noise voltage
    - 250 VACrms (50/60Hz)
- The DX100P is an INSTALLATION CATEGORY II product.

**Wiring Procedure**

1. Turn OFF the power switch of the DX100P and remove the input terminal cover.
2. Connect the input signal wires to the input terminals.
3. Replace the input terminal cover and fasten it with screws.

**Note**

Input signal wires of diameter less than or equal to 0.3 mm may not be secured firmly for clamped input terminals. Fold over the conducting section of the wire, for example, to make sure that the wire is securely connected to the clamped input terminal.

## 2.4 Input Signal Wiring

- **Input Terminal Position**

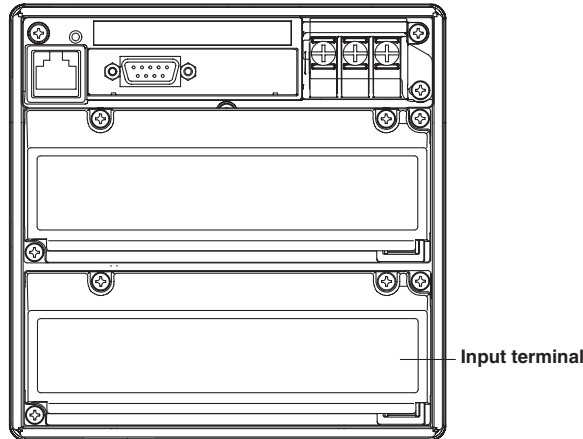

- **Terminal Arrangement**  
**DX102/DX104**

**Standard Input Terminals**

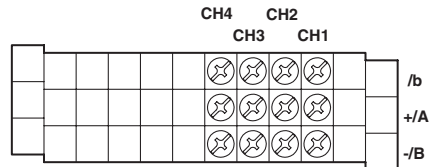

**Clamped Input Terminals (/H2)**

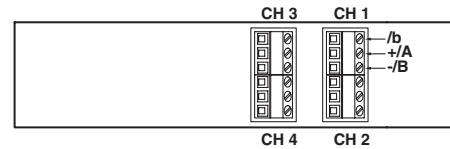

**DX106**  
**Standard Input Terminals**

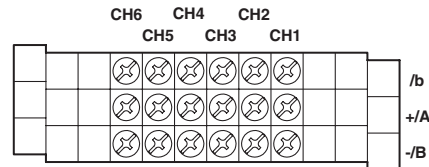

**Clamped Input Terminals (/H2)**

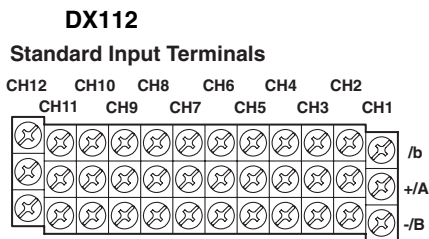
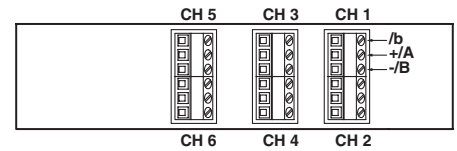

**Clamped Input Terminals (/H2)**

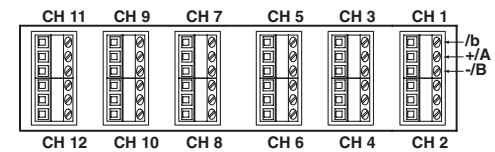

**Note**

For the DX106P and DX112P, RTD input terminals A and B are isolated on each channel. Terminal b is shorted internally across all channels. However, for options /N1 (Cu10, Cu25 RTD input, 3 terminal isolated RTD) and /N2 (3 terminal isolated RTD), input b is isolated for each channel.

• Wiring Diagram

DC Voltage and DI Input

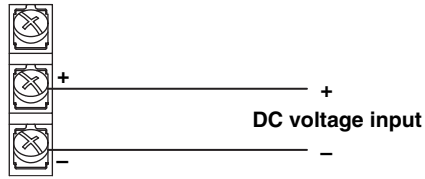

Thermocouple Input

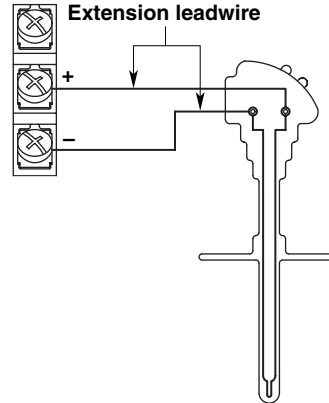

Resistance Temperature Detector Input

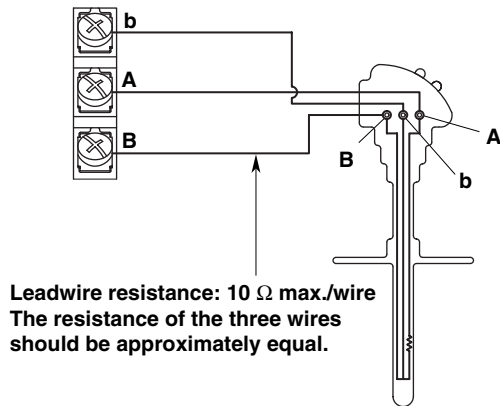

DC Current Input

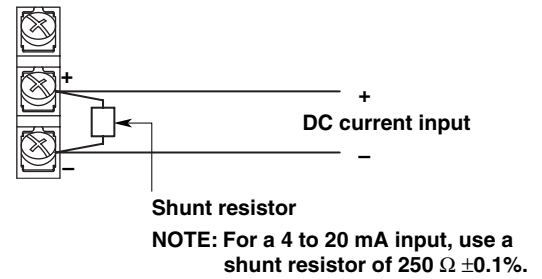

---

## 2.5 Alarm Output Wiring (/AR1, /AR2, /A3 Option)

---



### **WARNING**

- To prevent electric shock, ensure the main power supply is turned OFF.
  - If a voltage of more than 30 VAC or 60 VDC is to be applied to the alarm output terminal, use ring-tongue crimp-on lugs with insulation sleeves on all terminals to prevent the wires from slipping out when the screws become loose. Furthermore, use double-insulated wires (dielectric strength of 2300 VAC or more) for the signal wires on which a voltage of more than 30 VAC or 60 VDC is to be applied. For all other wires, use basic insulated wires (dielectric strength of 1350 VAC). To prevent electric shock, attach the terminal cover after wiring and make sure not to touch the terminals.
- 



### **CAUTION**

To prevent fire, use signal wires having a temperature rating of 70°C or more.

---

### Wiring Procedure

1. Turn OFF the power switch of the DX100P and remove the cover for the option terminal.
2. Connect the alarm output cables to the terminal.  
The terminal arrangement will be one of the figures shown on the next page depending on the alarm output relay option (number of outputs) and the /F1 option.
3. Replace the terminal cover and fasten it with screws.

**Alarm Terminal Position**

Enclosed in parentheses are the relay numbers assigned to each option terminal.

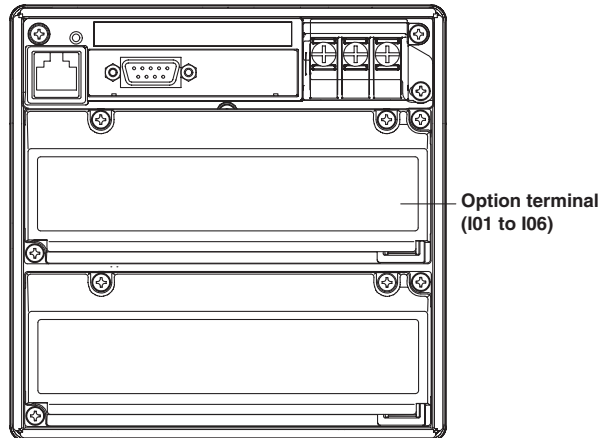

**Terminal Arrangement (Only the position of the alarm output terminals is indicated.)**

When the relay is not energized, NC is closed and NO is open. C is the common terminal.

- /AR1, /AR1/F1

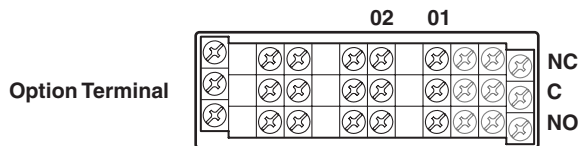

- /AR2, /AR2/F1

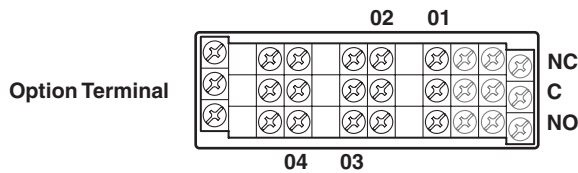

- /A3, /A3/R1

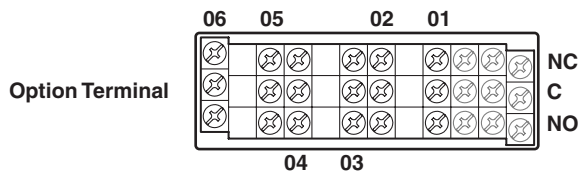

**Contact Specifications**

Item	Specification
Output type	Relay transfer contact (energize/de-energize switchable)
Output capacity	250 VAC (50/60 Hz), 3A 250 VDC, 0.1 A (resistive load)
Dielectric strength	1500 VAC (50/60 Hz) for one minute between output terminals and the ground terminal

For details related to the switching of energized/de-energized state of the alarm relays, see section 4.1.

## 2.6 FAIL/Memory End Wiring (/F1 Option)



### WARNING

- To prevent electric shock, ensure the main power supply is turned OFF.
- If a voltage of more than 30 VAC or 60 VDC is to be applied to the FAIL/Memory End output terminal, use ring-tongue crimp-on lugs with insulation sleeves on all terminals to prevent the wires from slipping out when the screws become loose. Furthermore, use double-insulated wires (dielectric strength of 2300 VAC or more) for the signal wires on which a voltage of more than 30 VAC or 60 VDC is to be applied. For all other wires, use basic insulated wires (dielectric strength of 1350 VAC). To prevent electric shock, attach the terminal cover after wiring and make sure not to touch the terminals.



### CAUTION

To prevent fire, use signal wires having a temperature rating of 70°C or more.

### Wiring Procedure

1. Turn OFF the power switch of the DX100P and remove the cover for the option terminal.
2. Connect the FAIL/Memory End output cables to the terminal.  
The terminal arrangement for the FAIL/Memory End output option is as follows.

#### Terminal Position

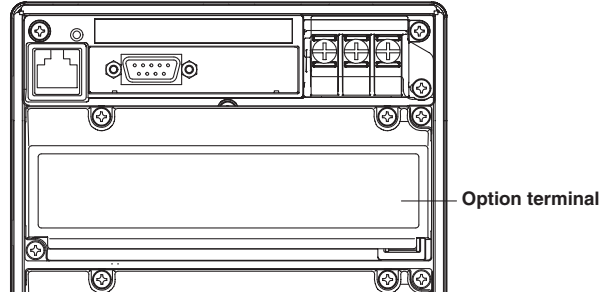

#### Terminal Arrangement (Only the position of the FAIL/Memory End output terminals is indicated.)

When the relay is not energized, NC is closed and NO is open. C is the common terminal.

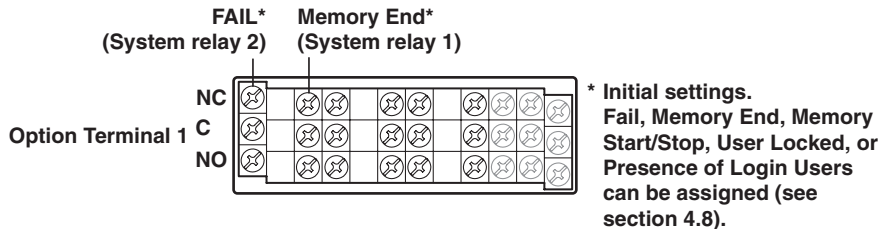

3. Attach the option terminal cover and secure it with screws.

#### Note

For details on the relay operation, see section 1.8.

### Contact Specifications

The contact specification is the same as that for the alarm output. See section 2.5.

## 2.7 Remote Control Wiring (/R1 Option)



### WARNING

To prevent electric shock, ensure the main power supply is turned OFF.



### CAUTION

To prevent fire, use signal wires having a temperature rating of 70°C or more.

### Wiring Procedure

1. Turn OFF the power switch of the DX100P and remove the cover for the option terminal.
2. Connect the remote control signal cables to the terminal.  
The terminal arrangement for the remote control option is as follows.

#### Terminal Position

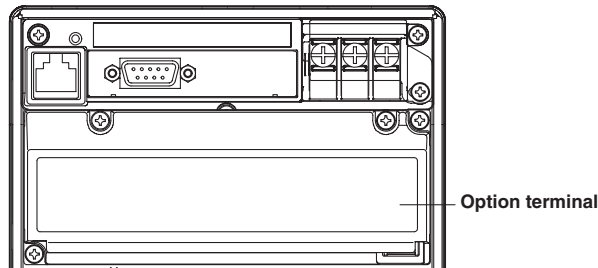

#### Terminal Arrangement (Only the position of the remote control terminals is indicated.)

C is a common terminal for terminals 1 through 8.

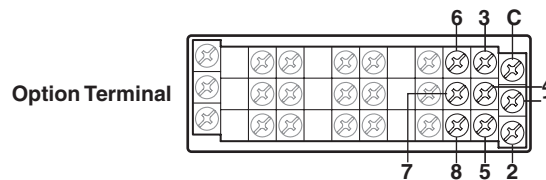

3. Replace the terminal cover and fasten it with screws.

#### Note

Use shielded wires for the remote control wires to reduce the effects of noise. Connect the shield to the ground terminal of the DX100P.

### Input Specifications

Item	Specification
Input signal	Voltage-free (dry) contact, open-collector (TTL or transistor)
Input conditions	ON voltage: Less than or equal to 0.5 V (30 mA DC) Leakage current in the OFF state: No more than 0.25 mA Signal duration: 250 ms minimum
Input type	Photocoupler isolation (one side common) Internal isolated power source (5 V $\pm$ 5%)
Dielectric strength	500 VDC for one minute between input terminals and the ground terminal

For the control actions and setting procedures, see sections 1.9 and 4.5 respectively.

## 2.8 24 VDC Transmitter Power Supply Wiring (/ TPS2, /TPS4, Option)



### WARNING

To prevent electric shock, ensure the main power supply is turned OFF.



### CAUTION

- Never short-circuit the power supply terminals or apply an external voltage, otherwise damage to the DX100P may result.
- Do not use current that exceeds the maximum output current (25 mADC). This may cause damage to the DX100P.
- To prevent fire, use signal wires having a temperature rating of 70°C or more.

### Wiring Diagram

Arrange the wires as shown below.

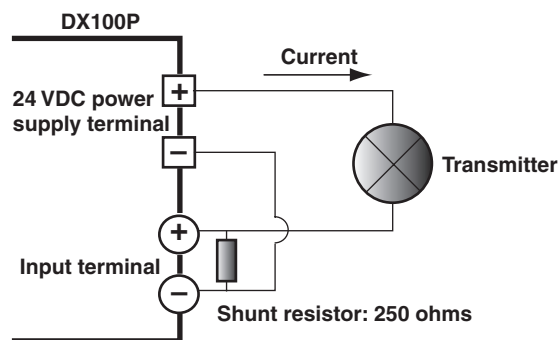

### Wiring Procedure

1. Turn OFF the power switch of the DX100P and remove the cover for the option terminal.
2. Connect the 24 VDC power supply wires to the terminal.  
The terminal arrangement for the 24 VDC power supply option is as follows.

#### Terminal Position

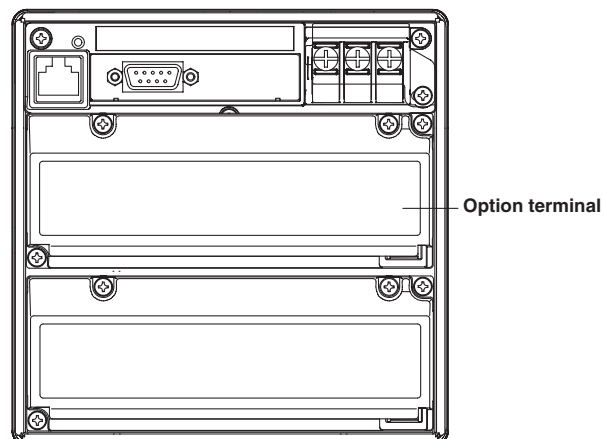



## 2.8 24 VDC Transmitter Power Supply Wiring (/TPS2, /Tps4, Option)

- /TPS2

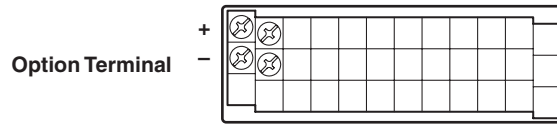

- /TPS4

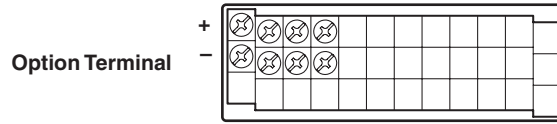

### **Note**

Use shielded wires to reduce the effects of noise. Connect the shield to the ground terminal of the DX100P.

## 2.9 Power Supply Wiring

### For Panel Mount Type

#### Precautions to Be Taken When Wiring the Power Supply

To prevent electric shock and damage to the DX100P, observe the following warnings.



#### WARNING

- To prevent electric shock, ensure the main power supply is turned OFF.
- To prevent the possibility of fire, use 600 V PVC insulated wire (AWG18) or an equivalent wire for power wiring.
- Make sure to earth ground the protective earth terminal through a grounding resistance less than 100  $\Omega$  before turning ON the power.
- Use crimp-on lugs (designed for 4 mm screws) for power and ground wiring termination (See section 2.4, "Input Signal Wiring").
- To prevent electric shock, make sure to attach the transparent terminal cover.
- Make sure to provide a power switch (double-pole type) on the power supply line in order to separate the DX100P from the main power supply. Put an indication on this switch as the breaker on the power supply line for the DX100P.

#### Switch Specification

Rated power current: 1 A or more (except /P1 model), 3 A or more (/P1 model)

Rated rush current: 60 A or more (except /P1 model), 70 A or more (/P1 model)

Use a switch complied with IEC60947-1, 3.

- Connect a fuse (between 2 A and 15 A) to the power line.  
The power switch and fuse used on the power supply line should be
  - CSA approved (for the use in North America) or
  - VDE approved (for the use in Europe).
- Do not add a switch or fuse to the ground line.

Use a power supply that meets the following conditions:

Item	except /P1 model	/P1 model
Rated power supply	100 to 240 VAC	24 VDC/AC
Allowable power supply voltage range	90 to 132 or 180 to 264 VAC	21.6 to 26.4 VDC/AC
Rated power supply frequency	50/60 Hz	50/60 Hz (for AC)
Allowable power supply frequency range	50/60 Hz $\pm$ 2%	50/60 Hz $\pm$ 2% (for AC)
Maximum power consumption	45 VA (100 V), 62 VA (240 V)	30 VA (for DC), 45 VA (for AC)

#### Note

Do not use a supply voltage in the range 132 to 180 VAC, as this may have adverse effects on the measurement accuracy (applies to all models except the ones with the /P1 option).

**Wiring Procedure**

1. Turn OFF the power switch of the DX100P and remove the transparent power terminal cover.
2. Connect the power supply wires and the protective ground wire to the power terminals.

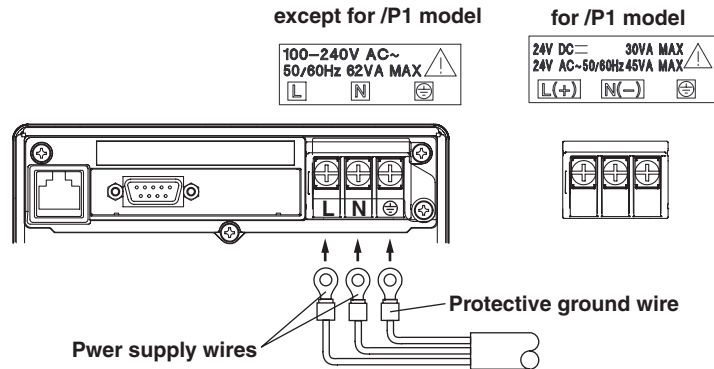

3. Replace the power terminal cover, and fasten it with screws.

**For the Desktop Type**

**Models with /H5D, /H5F, /H5R, or /H5J Option**

**• Precautions to Be Taken When Wiring the Power Supply**

To prevent electric shock and damage to the DX100P, observe the following warnings.



**WARNING**

- Before connecting the power cord, ensure that the power supply voltage matches the voltage rating for the instrument, and that it is within the maximum rated voltage for the power cord itself.
- Confirm that the power is turned OFF before connecting the power cord.
- To prevent electric shock and the possibility of fire, use only the power cord for the DX100P that is supplied by YOKOGAWA.
- Always use protective earth terminal to prevent electric shock. Connect the power cord of the DX100P to a three-pole power outlet that has a protective earth terminal.
- Never use an extension cord that does not have protective earth terminal, otherwise the protection function will be compromised.

Use a power supply that meets the following conditions:

Item	conditions
Rated power supply	100 to 240 VAC
Allowable power supply voltage range	90 to 132 or 180 to 264 VAC
Rated power supply frequency	50/60 Hz
Allowable power supply frequency range	50/60 Hz±2%
Maximum power consumption	45 VA (100 V), 62 VA (240 V)

**Note**

Do not use a supply voltage in the range 132 to 180 VAC, as this may have adverse effects on the measurement accuracy (applies to all models except the ones with the /P1 option).

## 2.9 Power Supply Wiring

---

- **Connection Procedure**

1. Check that the power switch of the DX100P is turned OFF.
2. Connect the power cord (supplied with the DX100P) to the power connector on the rear panel of the DX100P.

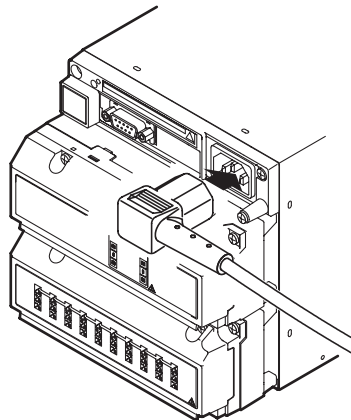

3. Ensure that the power supply voltage is within the maximum rated voltage for the power cord, then plug the other end of the power cord into an outlet that meets the conditions below. Use only a 3-prong AC outlet with a protective ground terminal.

### **Models with /H5 Option**

The wiring procedure of the power supply is the same as that for the panel mount type.

## 3.1 Turning ON/OFF the Power

### Procedure

#### Turning ON the Power

1. Check the following points before turning ON the power.
  - The power cord/wires are connected correctly to the DX100P.
  - The DX100P is connected to the correct power supply (see section 2.9).
  - The proper fuse is set (see section 10.4).

### CAUTION

If the input wires are connected in parallel with another instrument, avoid turning ON/OFF the DX100P or the other instrument when either one is in operation. This may affect the reading.

2. Open the front cover.
3. Turn ON the power switch.
4. Close the cover.  
After performing a self-diagnosis for a few seconds, a screen in the operation mode appears.

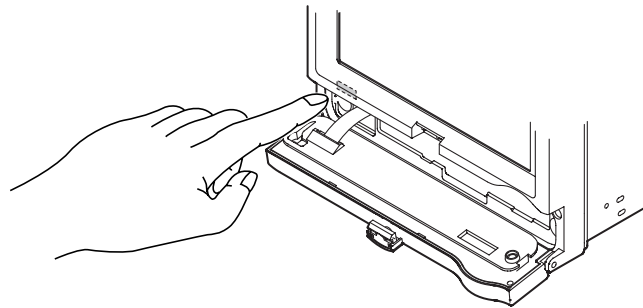

#### Note

- If nothing is displayed when the power switch is turned ON, turn OFF the power switch and check the points listed in step 1. After checking the points, turn ON the power switch again. If the unit still does not work, it is probably malfunctioning. Contact your nearest YOKOGAWA dealer for repairs.
- If an error message is displayed on the screen, take measures according to the description in chapter 9, "Troubleshooting."
- Turn ON the power, let the DX100P warm up for at least 30 minutes, and then start the measurements.

#### Turning OFF the Power Switch

1. Open the front cover and remove the external storage medium (see section 3.2).
2. Turn OFF the power switch.
3. Close the front cover.

## 3.2 Inserting/Removing the External Storage Medium

This section describes the procedures to insert and remove the external storage medium. Two types of media can be used depending on the specification.

- Model DX1\*\*-2: Zip disk
- Model DX1\*\*-3: Flash memory card

For the handling procedure of the storage medium, see section 2.1.

### Procedure

#### Inserting the Storage Medium

1. Open the front cover by pressing down on the knob that is located in the center of the upper section of the cover and pulling forward. Insert the medium into the drive until a click is heard.

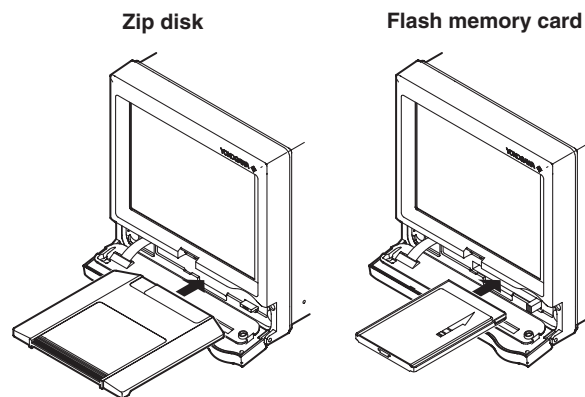

2. When the power switch is turned ON, closing the front cover causes the DX100P to detect the existence of an external storage medium in the drive. If the storage medium is detected, an external storage medium icon is displayed in the status display section of the screen.

External storage medium icon



#### Note

Keep the front cover closed during operation except when accessing the power switch and the external storage medium. This will protect the storage medium and the drive from foreign particles such as dust.

#### Removing the Storage Medium

Floppy disks and flash memory cards can be removed from the drive regardless of whether the DX100P is turned ON or OFF. **Zip disks cannot be removed when the DX100P is turned OFF.**

1. Check that the storage medium is not being accessed.

#### Note

- The access indicator is lit while the storage medium is being accessed.
- A message "Data are being saved to the medium." is displayed while measured/computed data are being saved to the medium.

2. Open the front cover by pressing down on the knob that is located in the center of the upper section of the cover and pulling forward. Push the eject button to remove the storage medium.
3. Close the front cover. If the DX100P is turned ON, the external storage medium icon in the status display section disappears.

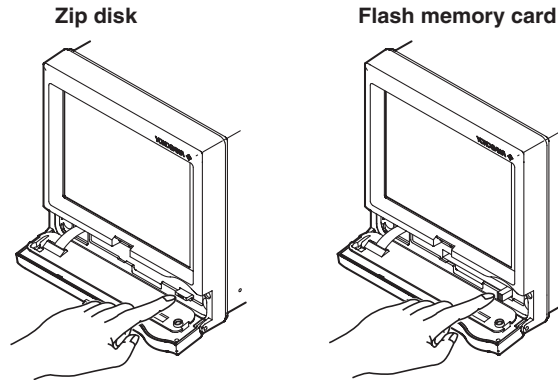

**Note**

- You cannot eject the Zip disk unless you log in using key operations as a user who is permitted to eject the Zip disk (see section 4.4).
- The Zip disk can be removed from the time the power is turned ON until the DX100P boots up.

**Procedure When the Zip Disk Cannot Be Ejected**

If the Zip disk cannot be removed by performing the steps given in the “Removing the storage medium” section, carry out the following steps to remove it.

1. Open the front cover by pressing down on the knob that is located in the center of the upper section of the cover and pulling forward.
2. Insert a pin of approx. 1 mm in diameter into the eject button hole and press slowly. This will cause the Zip disk to be ejected.

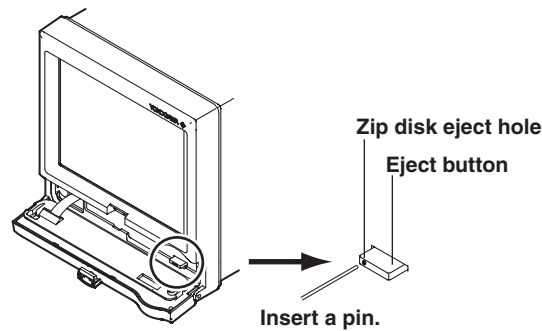

**Explanation**

**Format Type of the External Storage Media**

Use a formatted storage medium on the PC.

- Zip disk: FDISK 1 partition (hard disk format)
- Flash memory card: FDISK 1 partition (hard disk format)

## 3.3 Run Mode

The DX100P has three run modes, operation mode, engineering mode, and system mode. The function and relationship of each mode is described below.

### Mode Types

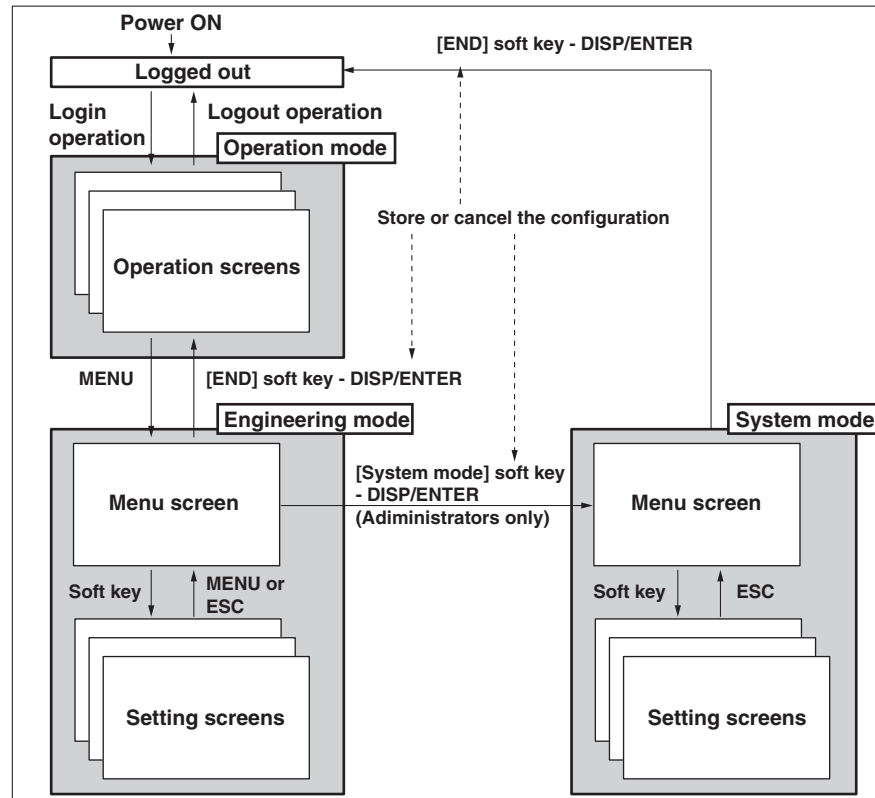

#### Operation Mode

- This is the mode you enter when you turn ON the power and log in.
- This mode is used to acquire measured/computed data to the internal memory and save the data to the external storage medium.
- The operation screen is displayed.

#### Engineering Mode\*

- The DX100P enters this mode when the MENU key is pressed in the operation mode.
- The DX100P cannot enter this mode when Memory Start is executed.
- Settings such as input range and alarms are entered.
- Input scan is being executed. Alarm detection is also in operation.

#### System Mode\*

- This mode can be entered only when you logged in as an administrator.
- This mode is entered by pressing the system mode soft key on the engineering mode menu screen.
- Sets the basic environment of the DX100P such as the input format and the save format of measured/computed data.
- The input scan operation stops when this mode is entered. Alarm detection is also disabled. The condition of the alarm output relay (option) retains the condition existing immediately before.

\* The DX100P can be configured so that a portion of the settings of these modes can be changed even when data acquisition is in progress (see page 3-6).



## 3.4 Operations in the Operation Mode

### Note

Operations in the operation mode can be executed only when logged in as an administrator or a user that has permission to use the operation (see section 1.5).

### Operations Using the Arrow Keys and the DISP/ENTER Key

Switches the operation screen such as trend, digital, and bar graph. For the operating procedure, see chapter 7.

### Operations Using the START/STOP Key

Executes Memory Start/Stop. For the operating procedure, see section 6.2.

### Operations Using the FUNC Key and Soft Keys

Pressing the FUNC key displays a menu that is assigned to the soft keys at the bottom of the screen. The menu varies depending on the setup information and options.

#### Menu Example of the FUNC Key

Logout	Batch	Message	Manual sample	Next 1/4	
Math STOP	Snap shot	Save Display	Data Load	Next 2/4	Math START Math reset
File List	Log	Password change	E-Mail START	Next 3/4	Save Event
FTPtest	E-Mail test	SNTP	Modbus master	Next 4/4	Locked ACK

Menu	Reference	Function (conditions to be displayed on the soft key menu)
Logout	6.1	Log out (only when logged in)
Batch	8.1	Display the batch screen.
Message	8.2	Write messages.
Manual sample	8.3	Saves the measured/computed data (instantaneous values) once.
Math START/Math STOP	8.4	Start/stop computation (only for models with the computation option (/M1))
Math reset	8.4	Set the computed value of the computation channel to 0 (only on models with the computation option (/M1) while the computation is stopped).
Math ACK	8.4	Set the icon indicating computation data dropout back to normal (only on models with the computation option (/M1) when computation data dropout occurred)
Snapshot	8.5	Saves the current screen image data to the external storage medium.
Save Display/Save Event	8.6	Saves the display data or event data to the external storage medium (only when [Type of process] is set to [Continue] and Memory Start is executed.)
Data Load	8.7	Loads the display data or event data from the external storage medium and displays the data on the sign record screen.
File list	8.8	Displays a list of files of the external storage medium.
Log	8.9	Displays the log screen/system screen.
Password change	8.10	Changes the login password.
E-Mail START/E-Mail STOP	*	Enables/disables the e-mail transmission function.
FTP test	*	Executes an FTP test.
E-Mail test	*	Transmit test mail messages to recipients 1 and 2.
SNTP	*	Adjusts the time to the time retrieved from an SNTP server.
Modbus master	*	Displays the status of the data read using the Modbus master function.
User Locked ACK	8.12	Clearing the User Locked icon (operation allowed only when you logged in as an administrator)

\* See the DX100P/DX200P Communication Interface User's Manual, IM 04L05A01-17E.

### 3.4 Functions and Operations in the Operation Mode

---

#### Procedure

Below is the procedure for carrying out “File list” that is indicated in the second line of the menu examples.

1. Pressing the FUNC key displays a menu that is assigned to the soft keys at the bottom of the screen.
2. Press the [Next] soft key to show the next menu.
3. Press the [File list] soft key. The FUNC key menu is cleared and a list of files of the external storage medium is displayed.

#### Operations Using Other Keys

##### **USER Key**

Executes the assigned functions (see section 5.8).

#### Setup Operation While Data Acquisition Is in Progress

The following settings can be entered while data acquisition is in progress. For a description of the settings required to use this function, see section 4.14.

##### **Operations That Can Be Carried Out by an Administrator**

- Set the calibration correction (/CC1 option) (see section 5.21)
- Register administrators and users (see section 4.4)
- Change the time (see section 5.15)

##### **Operations That Can Be Carried Out by a User**

- Set the calibration correction (/CC1 option) (see section 5.21)

##### **Note**

---

If an auto save operation takes place during setup operation, the DX100P returns to the operation mode automatically and the setup data is canceled.

---

## 3.5 Setting the Functions (System Mode and Engineering Mode)

### Procedure for Setting Functions

Set an administrator first. Then, log in as an administrator and set items of the system mode and engineering mode.

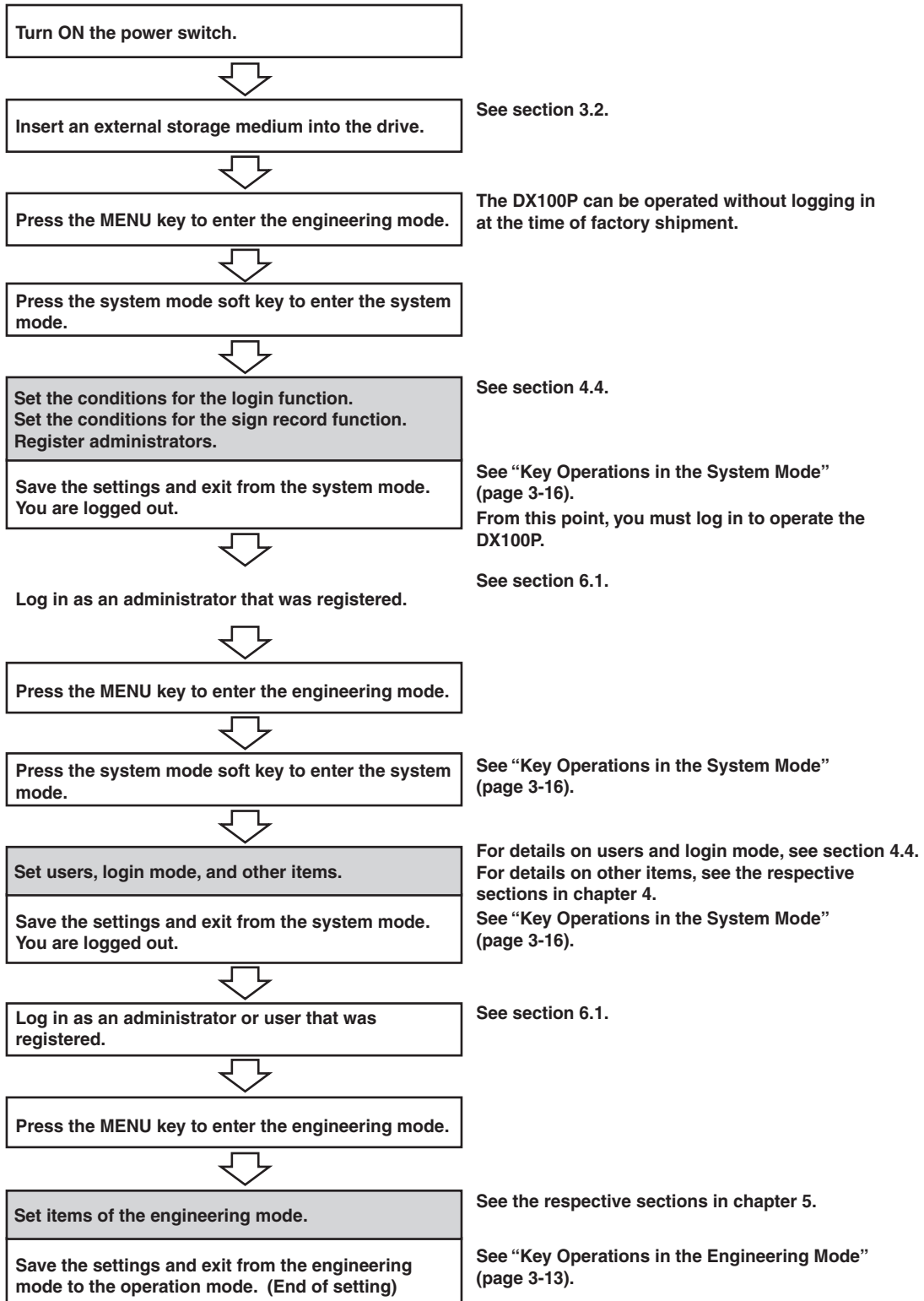

### 3.5 Setting the Functions (System Mode and Engineering Mode)

#### The Menu Screen and Items of the Engineering Mode

The [Math set1] and [Math set2] are displayed when the /M1 option is equipped. The [Calibration correction settings] is displayed when the /CC1 option is equipped. [System Mode] appears only when the login function is not used or when the login function is used and you log in as an administrator.

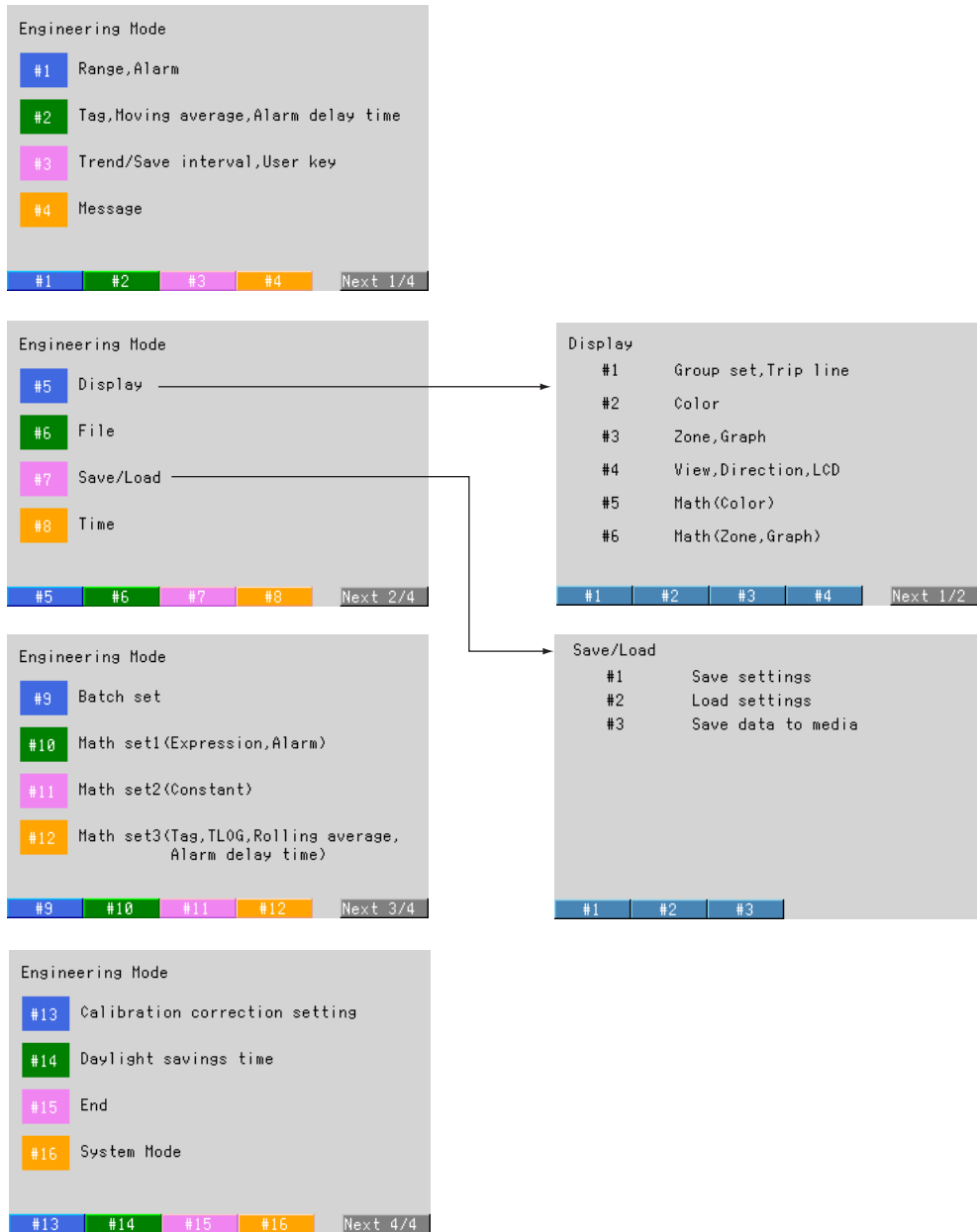

### 3.5 Setting the Functions (System Mode and Engineering Mode)

Soft key	Settings in the engineering mode Title	Item	Ref. section
#1	Range	Input type, measurement range, upper and lower limits of span, reference channel for difference computation, upper and lower limits of scale, Unit	5.1
	Alarm	Alarm type, Alarm value, Output relay number	5.2
#2	Tag	Tag name	5.3
	Filter	Filter time constant/Off (DX102P/DX104P)	5.4
	Moving average	Number of samples for the moving average/Off (DX106P/DX112P)	5.4
	Alarm delay time		5.5
#3	Trend/Save interval	Trend display update rate, Auto save interval	5.6
	USER key	Assign an action to the USER key	5.8
#4	Message	Message string	5.16
#5	Display		
#5 - #1	Group set Trip line	Group name, Assign channels to groups Trip line position, display color	5.9
#5 - #2	Color	Measurement channel display color	5.10
#5 - #3	Zone	Zone upper and lower limits	5.11
	Graph	Number of scale divisions, Bar graph base position Specify the scale display position for trends	5.12
	Partial	Turn On/Off partial expanded display, Position and boundary for the partial expanded display	5.11
#5 - #4	View Direction	Trend display direction, Bar graph display direction, Background color (white or black), Trend line width, Trip line width, Grid for the trend display, Group display switching interval (Scroll time), Scale digit	5.13
	LCD	LCD brightness, Turn On/Off the LCD backlight saver, Transition time for the LCD backlight saver and conditions that restore the backlight	5.14
#5 - #5	Math (Color)	Computation channel display color	5.10
#5 - #6	Math (Zone)	Zone upper and lower limits	5.11
	Math (Graph)	Number of scale divisions for the trend and bar graph displays, Bar graph base positions, Specify the scale display position for trends	5.12
	Math (Partial)	Turn On/Off partial expanded display Position and boundary for the partial expanded display	5.11
#6	File	Header string to be written to file A name of directory to which data are to be saved	5.7
#7	Save/Load		
#7 - #1	Save settings	Save setup data to the external storage medium	5.23
#7 - #2	Load settings	Load setup data from the external storage medium	5.23
#7 - #3	Save data to media	Save data to the external storage medium	5.24
#8	Time	Enter the current time	5.15
#9	Batch set	Use/do not use lot number, Auto increment of lot number, Headers 1 to 3	5.17
#10	Math set1 (Expression)	Computing equations, display span, and unit for computation channels	5.18
	Math set1 (Alarm)	Alarm type, Alarm value, Output relay number	5.18
#11	Math set2 (Constant )	Constants (K01 to K12)	5.18
#12	Math set3 (Tag)	Tag names of the computation channels	5.3
	Math set3 (TLOG)	Timer number used in TLOG, sum unit	5.19
	Math set3 (Rolling average)	Turn On/Off the rolling average, Sampling interval and the number of samples for the rolling average	5.20
	Math set3 (Alarm delay time)		5.5
#13*	Calibration correction	Segments for calibration correction	5.21
#14*	DST	Start/end times of DST	5.22
#15*	End	End the engineering mode	3.5
#16*	System Mode	Enter the system mode	3.5

\* The soft key varies depending on optional functions equipped.

### 3.5 Setting the Functions (System Mode and Engineering Mode)

#### The Menu Screen and Items of the System Mode

The menu screen and items of the system mode are as follows. Enclosed in parentheses are reference sections.

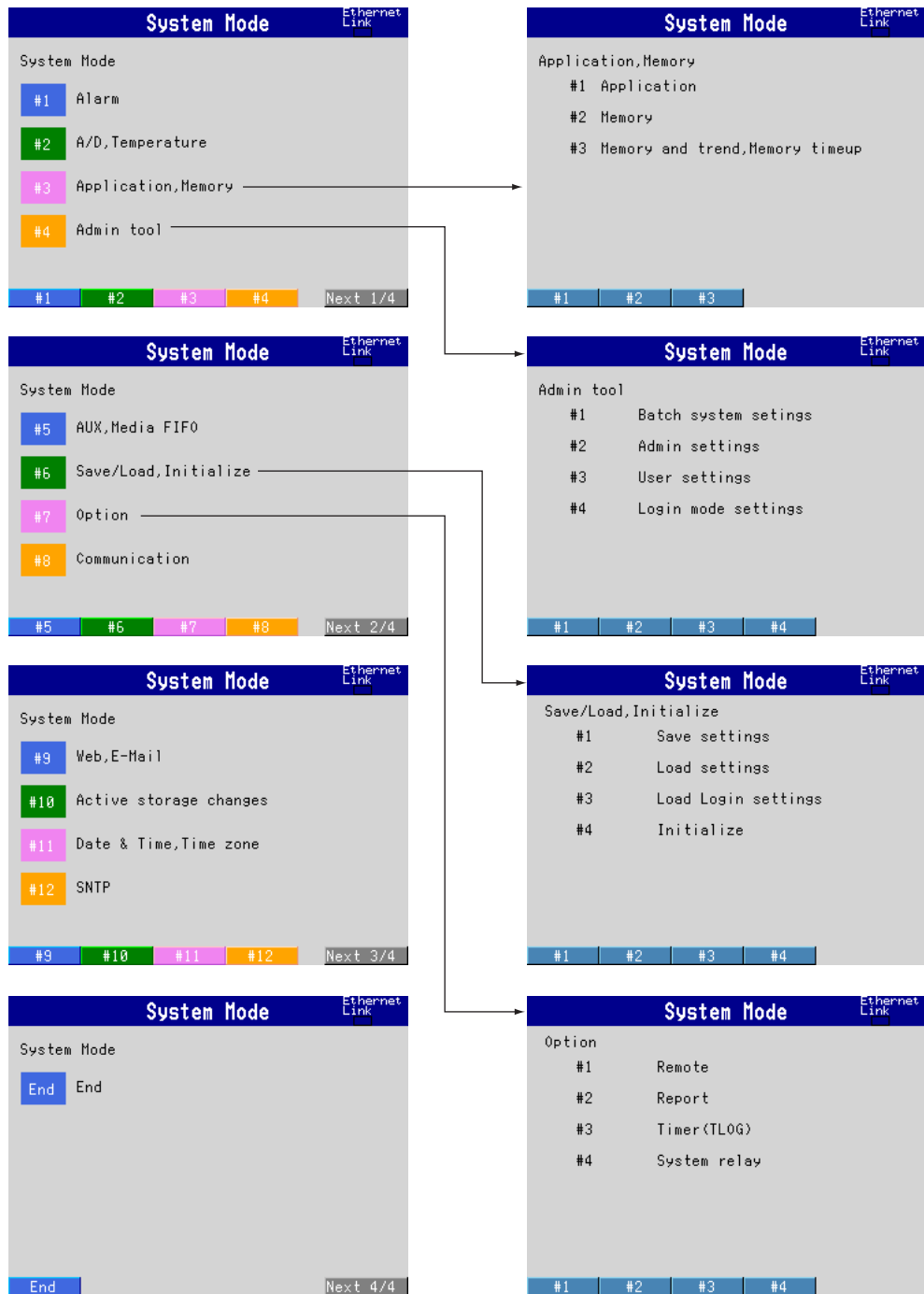

### 3.5 Setting the Functions (System Mode and Engineering Mode)

Soft key	Settings in the system mode Title	Item	Ref. section
#1	Alarm	Reflash alarm AND operation of alarm output relays Energize/de-energize alarm output relays Hold/non-hold alarm output relays Hold/non-hold alarm displays Rate-of-change alarm interval Turn On/Off the alarm hysteresis	4.1
#2	A/D	Integration time of the A/D converter Scan interval Burn out Off/Up/Down Reference junction compensation (internal or external, compensation voltage when using external) Temperature Temperature unit	4.2 4.2
#3	Application, Memory		
#3 - #1	Application	Type of process Whether to clear the displayed waveform at Memory Start	4.3
#3 - #2	Memory	Save method to the external storage medium Type of data to be acquired Event data • Sampling interval • Data length (file size)	4.3
#3 - #3	Memory & trend	Measurement channels to acquire data/display the waveform Computation channels to acquire data/display the waveform	4.3
	Memory timeup	Date and time to save data	4.3
#4	Admin tool		
#4 - #1	Batch system settings	Login settings • Use/Not use user ID • Auto logout On/Off • Enable/Disable screen change operation while logged out Sign record settings • Use/Not use electronic signature function • Sign at Memory Stop On/Off • Use/Not use user ID when signing	4.4
#4 - #2	Admin settings	Registration of administrator Login method, user name, user ID, password, password expiration duration	4.4
#4 - #3	User settings (Specifiable only when logged in as an administrator)	Registration of user Login method, user name, user ID, password, password expiration duration, Login mode No. Enable/disable calibration correction settings	4.4
#4 - #4	Login mode settings (Specifiable only when logged in as an administrator)	Login mode number Sign authority level or no authority Enable/disable key operations Enable/disable alarm ACK operation Enable/disable Zip disk removal Enable/disable other functions	4.4
#5	Aux	Tag display or channel number display Minimum remaining amount of internal memory at which to generate the alarm Displayed language Use/Not use partial expanded display Remote controller ID	4.9
	Media FIFO	Turn ON/OFF the FIFO operation of the storage medium	4.16
#6	Save/Load, Initialize		
#6 - #1	Save settings	Save setup data to the external storage medium	4.11
#6 - #2	Load settings	Load setup data from the external storage medium	4.11
#6 - #3	Load login settings	Load login settings* from the external storage medium	4.12
#6 - #4	Initialize	Initialize the setup data in the internal memory and clear measured/computed data and logs	4.13

\* Setup data that belongs to "Admin tool."

### 3.5 Setting the Functions (System Mode and Engineering Mode)

Soft key	Settings in the engineering mode		Ref. section
	Title	Item	
#7	Option		
#7 - #1	Remote (/R1)	Action assignment to remote terminals	4.5
#7 - #2	Report (/M1)	Report types Date/Time of creation Report channel assignments Sum scale	4.6
#7 - #3	Timer (TLOG) (/M1)	Timer mode (absolute time/relative time) Interval Reference time for the absolute timer Turn On/Off reset at each interval Turn On/Off data storage	4.7
#7 - #4	System relay (/F1)	Action assignment to system relays	4.8
#8	Communications		
#8 - #1	Ethernet (IP_Address)**		
#8 - #2	Ethernet (DNS)**		
#8 - #3	FTP transfer file**		
#8 - #4	FTP connection**		
#8 - #5	Control (Timeout, Keep alive)**		
#8 - #6	Serial, Memory out**		
#8 - #7	Modbus master (BASIC)**		
#8 - #8	Modbus master (DOMMAND)**		
#9	Web, E-Mail**		
#9 - #1	Web		
#9 - #2	Basic E-Mail settings**		
#9 - #3	Alarm E-Mail settings**		
#9 - #4	Scheduled E-Mail settings**		
#9 - #5	System E-Mail settings**		
#9 - #6	Report E-Mail settings**		
#10	Active storage change	Set the time, set the user registration, set the calibration correction, and turn ON/OFF the calibration correction change message	4.14
#11	Date & Time	Time deviation limit for allowing the gradual correction of the time	4.15
	Time Zone	Time deviation from GMT	4.10
#12	SNTP		
#12 - #1	Basic settings**		
#12 - #2	SNTP synched to start**		
End	End	End the system mode	3.5

\*\* See the DX100P/DX200P Communication Interface User's Manual (IM 04L05A01-17E).



### Key Operations in the Engineering Mode

Below is a description of the operating procedure when the name of message group 2 is set to "P1process."

**Procedure**

#### Entering the Engineering Mode

**Note**

- Engineering mode can be entered only when logged in as an administrator or a user that has permission to enter the engineering mode (see section 1.5).
- You cannot enter the engineering mode when Memory Start is executed, when the sign record screen is displayed, when saving data to an external storage medium, or when there is data that has not been saved to the external storage medium.

1. Press the MENU key. The engineering mode menu screen appears.

#### Setting the Message String

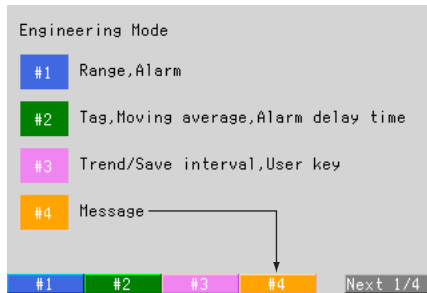

2. Press the [#4] (Message) soft key to show the setup screen.

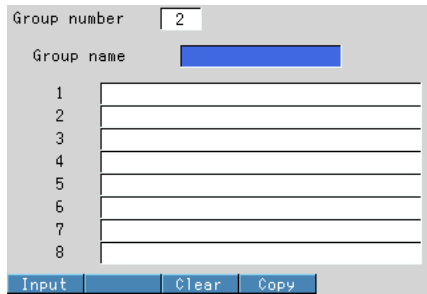

4. Pressing the [Input] soft key displays a window used to enter the group name.

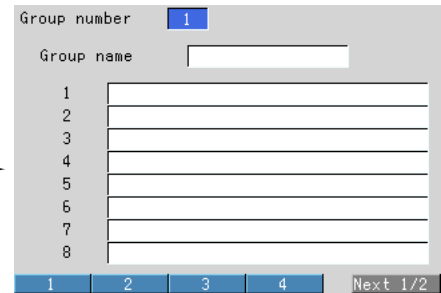
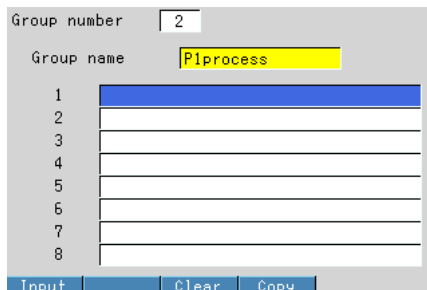

3. Press the [2] soft key to set "2" in the group number box. The cursor (blue) moves to the group name box.

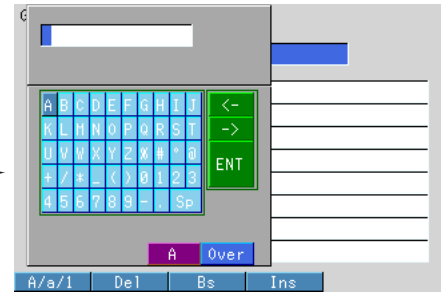

5. Enter the group name "P1process" and press the DISP/ENTER key. The group name box turns yellow, and the cursor moves to the message 1 box. For the procedures related to entering character strings, see section 3.6.

### 3.5 Setting the Functions (System Mode and Engineering Mode)

---

#### Confirming the Settings

6. Press the DISP/ENTER key. The parameters in the group name box are confirmed and turn white. The cursor returns to the first item (group number box) of the screen.

#### Canceling the Settings

6. Press the ESC key. A window appears for you to confirm the cancellation. Select [Yes] or [No] using the arrow keys and press the DISP/ENTER key.

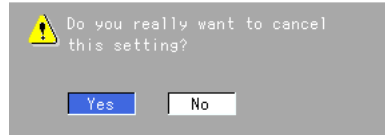

**Yes:** Cancels the settings and returns to the engineering mode menu screen.

**No:** Does not cancel the settings and returns to the screen that was shown before the ESC key was pressed.

#### Finishing the Settings

7. Press the MENU key or the ESC key to return to the engineering mode menu screen.

- **Returning to the Operation Mode**

8. Press the soft key corresponding to [End]. A window appears for you to select whether to save the settings. Select [Yes], [No], or [Cancel] using the arrow keys and press the DISP/ENTER key.

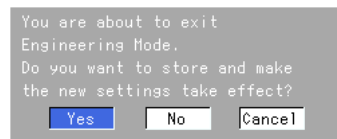

**Yes:** Saves the settings and returns to the operation mode. The settings of the engineering mode are activated. **When settings are changed, the setup file is saved to the external storage medium, and the log of setting change operations is saved to the setting change log.**

#### Note

---

If the external storage medium is not inserted, an error message "Media has not been inserted" appears and the DX100P cannot return to the operation mode. The error message is cleared by pressing the ESC key. Insert an external storage medium into the drive and carry out the procedure again.

---

**No:** Does not save the settings and returns to the operation mode. The settings of the engineering mode remain the same as those before the setting change operation.

**Cancel:** Cancels the "operation to end the engineering mode" and returns to the engineering mode menu screen. The setting changes made up to that point are retained.

• **Proceeding to the System Mode**

8. Press the system mode soft key\*. A window appears for you to select whether to save the settings. Select [Yes], [No], or [Cancel] using the arrow keys and press the DISP/ENTER key.

\* Appears only when logged in as an administrator.

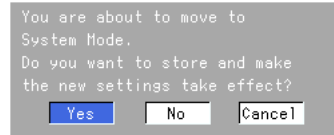

**Yes:** Saves the settings and proceeds to the system mode. The settings made in the engineering mode are activated. **When settings are changed, the setup file is saved to the external storage medium, and the log of setting change operations is saved to the setting change log.**

**Note**

If the external storage medium is not inserted, an error message “Media has not been inserted” appears and the DX100P cannot proceed to the system mode. The error message is cleared by pressing the ESC key. Insert an external storage medium into the drive and carry out the procedure again.

**No:** Does not save the settings and proceeds to the system mode. The settings of the engineering mode remain the same as those before the setting change operation.

**Cancel:** Cancels the “operation to proceed to the system mode” and returns to the engineering mode menu screen. The setting changes made up to that point are retained.

**Copying and Clearing Character Strings**

When entering character strings, you can copy and paste preexisting strings or clear them. The soft keys used to perform these operations appear only when these operations are possible.

For example, if you wish to set the string “Process1 Start” to message 1, you can copy the group name “Process1” and add the string “Start”.

**Procedure**

**Copying Character Strings**

1. Move the cursor to the group name box and press the [Copy] soft key. The [Paste] soft key appears.
2. Move the cursor to the message 1 box and press the [Paste] soft key. “Process1” is pasted.

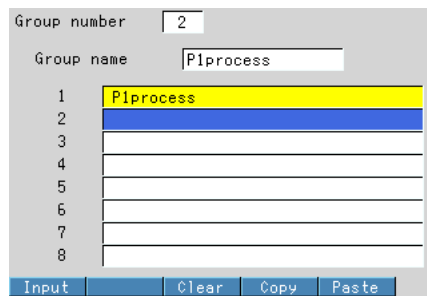

Clear Copy Paste

**Clearing Character Strings**

1. Move the cursor to the string you wish to clear and press the [Clear] soft key.

### 3.5 Setting the Functions (System Mode and Engineering Mode)

#### Key Operations in the System Mode

Below is a description of the operating procedure when displaying tag names in place of channel numbers.

#### Procedure

##### Entering the System Mode

1. Carry out the procedure described in “Proceeding to the System Mode” on the previous page to enter the system mode. The menu screen appears.

##### Note

- System mode can be entered only when logged in as an administrator.
- If you change the data save format in the system mode ([Application], [Memory] and [Memory and Trend] items of the [#2] setup screen), save the settings, and return to the operation mode, the measured/computed data in the internal memory is cleared. Save important data to the external storage medium before entering the system mode.

#### Setting the Use of Tag Names

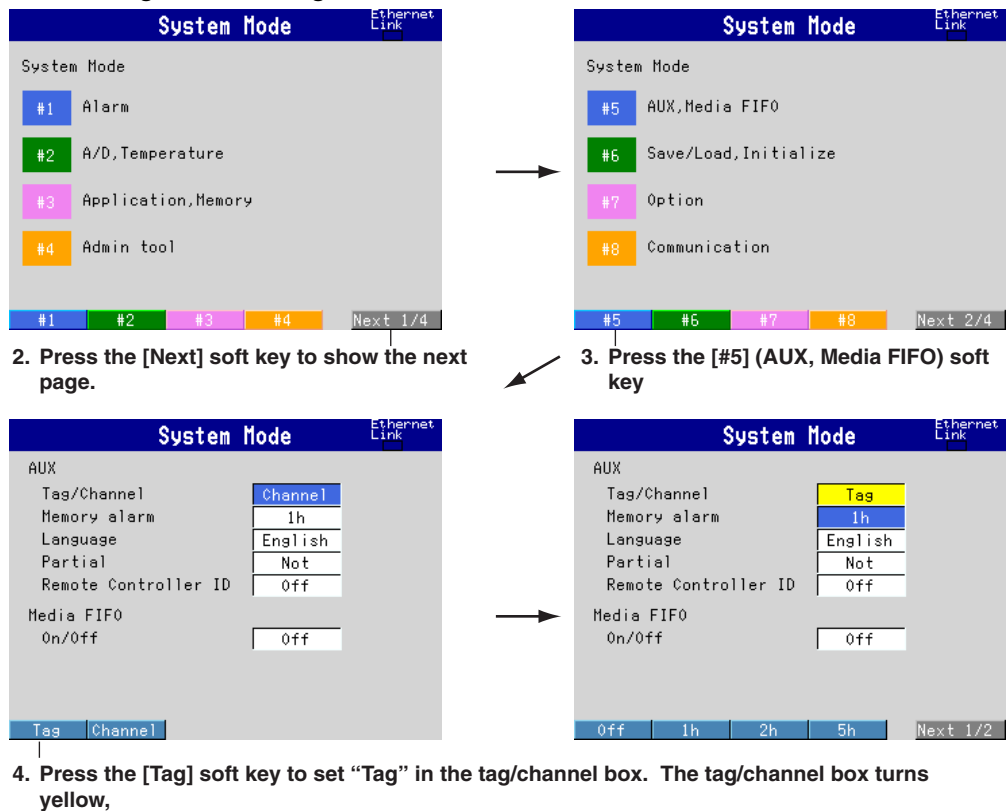

#### Confirming the Settings

5. Press the DISP/ENTER key to confirm the settings of the tag/channel box. Since the cursor moves to the first item on the screen (tab/channel box in this case), the tag/channel box turns blue.

#### Canceling the Settings

5. Press the ESC key. A window appears for you to confirm the cancellation.

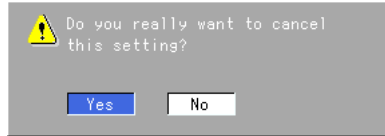

Select [Yes] or [No] using the arrow keys and press the DISP/ENTER key.

**Yes:** Cancels the settings and returns to the system mode menu screen.

**No:** Does not cancel the settings and returns to the screen that was shown before the ESC key was pressed.

#### Finishing the Settings

6. Press the ESC key to return to the system mode menu screen.
7. Press the [End] soft key. A window appears for you to select whether to save the settings.

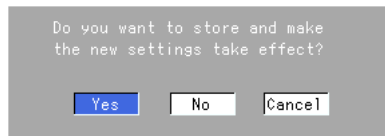

Select [Yes], [No], or [Cancel] using the arrow keys and press the DISP/ENTER key.

**Yes:** Saves the settings and you are logged out. The settings of the system mode are activated. **When settings are changed, the setup file is saved to the external storage medium, and the log of setting change operations is saved to the setting change log.**

#### Note

- If the external storage medium is not inserted, an error message "Media has not been inserted" appears and the DX100P cannot end the system mode. The error message is cleared by pressing the ESC key. Insert an external storage medium into the drive and carry out the procedure again.
- If you end the system mode, you are logged out.

**No:** Does not save the settings and you are logged out. The settings of the system mode remain the same as those before the setting change operation.

**Cancel:** Cancels the "operation to end the system mode" and returns to the system mode menu screen. The setting changes made up to that point are retained.

### 3.5 Setting the Functions (System Mode and Engineering Mode)

#### Function Setup Example

The function setup items and values for the case of a batch process when setting the users that can log in and batch conditions and recording the measured data of input channel CH1 as shown in the figure below are described.

**Bold characters indicate items set in the system mode;** thin characters indicate items set in the engineering mode or input items in the operation mode.

The numbers inside the parentheses correspond to the numbers assigned to the items of the setup screen on the succeeding pages.

#### Login conditions

<b>Adminstrator</b>	
<b>Login method:</b>	
<b>Key operations and via the Ethernet</b>	(1)
<b>User name: ABC2001</b>	(2)
<b>User ID: 5555</b>	(3)
<b>Password: AAAAAA</b>	(4)
<b>Password expire: Off</b>	(5)
<b>User</b>	
<b>Login method:</b>	
<b>Key operations</b>	(6)
<b>User name: ope1</b>	(7)
<b>User ID: 6666</b>	(8)
<b>Password: yvspmj</b>	(9)
<b>Password expire: 1 month</b>	(10)
<b>Login mode:</b>	
• <b>MENU key is prohibited</b>	(11)
• <b>Enable to sign as "Sign 1"</b>	(12)
<b>Auto logput: Off</b>	(13)

#### Sign record conditions

<b>Sign at Memory Stop</b>	(22)
<b>Use user ID when signing</b>	(23)

#### Batch conditions

Use lot number	(24)
Use lot number auto increment	(25)
Batch number: Process1	(26)
Lot number: 00000001	(27)
Header1: Manager ABC2001	(28)
Header2: Supervisor None	(29)
Header3: Operator ope1	(30)
Comment1: sample	(31)

#### Measurement channel

Channel: CH1	(14)
Tag name: TI-001	(15)
Input type: Type T thermocouple	(16)
Measuring range: 0.0 to 200.0 °C	(17)
Alarm: Upper limit alarm 155 °C	(18)
<b>Burn out: Up</b>	(19)
<b>Scan interval: 1 s</b>	(20)
<b>Use "Alarm ACK"</b>	(21)

#### DX100P

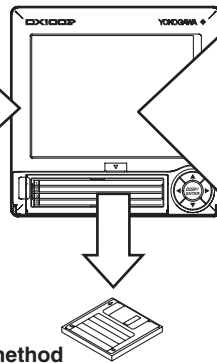

#### Display screens

Group: GROUP1	(32)
Trip line position: 78%	(33)
Scale: 0.0 to 200.0 °C(4 divisions)	(34)
Waveform update interval: 10 s	(35)
Trend display: Vertical	(36)
Bar graph display: Vertical	(37)
<b>Clear the displayed waveform at Memory Start.</b>	(38)

#### Measured data saving method

<b>Acquire the display data of CH1 and save them to the external storage medium.</b>	(39)
• <b>Type of process: Batch</b>	(40)
• Sampling interval: 10 s	(41)
• Saving interval: Automatically set by the DX100P (cannot be changed)	(42)
• Name of directory: P1DATA	(43)
• Header for data file: P1sample	(44)

Login Condition, Sign Record Condition (System Mode)

• Setting Loginn, Sign Record (See section 4.4)

System Mode Ethernet Link

Login settings

UserID Use/Not  (3) (8)

Auto Logout  (13)

Display change without Login

Sign record settings

Sign record Use/Not  Use Electronic Signature Function

Batch stop sign record  (22)

Sign record UserID  (23)

• Setting Administrator (See section 4.4)

System Mode Ethernet Link

Admin settings

Number  (1)

Login method  (1)

User name  (2)

User ID  (3)

Password  (4) "?????????" denauts the default password.

Password expire  (5)

• Setting Users (See section 4.4)

System Mode Ethernet Link

User settings

Number  (6)

Login method  (7)

User name  (7)

User ID  (8)

Password  (9) "?????????" denauts the default password.

Password expire  (10)

Login mode No.  Number of the login mode applied

• Setting Login Mode for Users (See section 4.4)

System Mode Ethernet Link

Number

Sign record  (12)

Key

START	<input type="text" value="Free"/>	Batch	<input type="text" value="Free"/>
STOP	<input type="text" value="Free"/>	Message	<input type="text" value="Free"/>
MENU	<input type="text" value="Lock"/>	Snapshot	<input type="text" value="Free"/> (11)
USER	<input type="text" value="Free"/>	Math	<input type="text" value="Free"/>
DISP/ENTER	<input type="text" value="Free"/>	Save data	<input type="text" value="Free"/>
		Load data	<input type="text" value="Free"/>
Alarm ACK	<input type="text" value="Free"/>	E-mail	<input type="text" value="Free"/>
Media eject	<input type="text" value="Free"/>	Other	<input type="text" value="Free"/>

Setting Data Saving (See section 4.3)

System Mode Ethernet Link

Application

Type of process  (40)

Trend clear  (38)

Setting Data Saving (See section 4.3)

System Mode Ethernet Link

Memory and trend

Meas CH/Math CH

First-CH  Last-CH

On/Off

Memory timeup

Timeup type

(39) "Display data" is set.

Setting Data Saving (See section 4.3)

System Mode Ethernet Link

Memory and trend

Meas CH/Math CH  (39) "CH1" is set.

First-CH  Last-CH

On/Off

Memory timeup

Timeup type

### 3.5 Setting the Functions (System Mode and Engineering Mode)

#### Setting Use of Alarm ACK Operation (System Mode, See section 4.1)

**System Mode** Ethernet Link

Alarm

Reflash

Relay AND

    Action

    Behavior

Indicator  (21)

Rate of change

    Increase

    Decrease

Hysteresis

#### Setting Scan Interval/Burnout (System Mode, See section 4.2)

**System Mode** Ethernet Link

A/D

Integrate

Scan interval  (20)

First-CH  Last-CH

Burnout set  (19)

RJC

Temperature

#### Setting Measurement Channel/Alarm (Engineering Mode, See section 5.1)

First-CH:  Last-CH:  (14)

Range

Mode  Range  Span\_L  Span\_U  (17)

(16)

(16)

Alarm

	Type	Value	Rly
1	<input type="text" value="On"/>	H	<input type="text" value="155.0"/>
2	<input type="text" value="Off"/>		<input type="text" value="Off"/>
3	<input type="text" value="Off"/>		
4	<input type="text" value="Off"/>		

(18)

#### Setting Tag Name (Engineering Mode, See section 5.3)

First-CH:  Last-CH:

Tag  (15)

Moving average

Count

Alarm delay time

#### Setting Group/Trip Line (Engineering Mode, See section 5.9)

Group number

Group set

Group name  (32)

CH set  (32) CH1, CH2, CH3, and CH4 are assigned to GROUP1 in this setting.

Trip line

	Position	Color
1	<input type="text" value="On"/> 78 %	<input type="text" value="Red"/>
2	<input type="text" value="Off"/>	
3	<input type="text" value="Off"/>	
4	<input type="text" value="Off"/>	

(33)



**Setting Display Direction (Engineering Mode, See section 5.13)**

View		LCD	
Direction		Brightness	4
Trend	Vertical	Saver	Off
Bargraph	Vertical		
Background	White		
Trend line	2 dot		
Trip line	2 dot		
Grid	10 div		
Scroll time	5s		
Scale digit	Normal		

**Setting Scale Divisionst (Engineering Mode, See section 5.12)**

First-CH:	01	Last-CH:	01
Zone		Partial	Off
Lower	0 %		
Upper	100 %		
Graph			
Division	4		
Bar graph	Normal		
Scale position	1		

**Setting Display Update Rate (Engineering Mode, See section 5.6)**

Time/div	5min	(35)(41)*1
Auto save interval	2h	(42)*2
User key		
Action	None	

\*1 When the display update rate [/div] is 5 min, the waveform is updated every 10 s.  
 \*2 Automatically determined when the type of process (40) is [Batch]. Fixed.

**Setting Header/Name of Directory (Engineering Mode, See section 5.7)**

File	
Header	Pisample
Directory name	PIDATA

**Setting Batch Function (Engineering Mode, See section 5.17)**

Batch	
Lot number Use/Not	Use
Auto increment	On
Header	
1	Manager ABC2001
2	Supervisor None
3	Operator ope1

**Setting Batch Number/Lot Number/Comment (Operation Mode, See section 8.1 or 6.2)**

Header1:	Manager ABC2001
2:	Supervisor None
3:	Operator ope1
Batch No.	Process1
Lot No.	1
Comment1:	Sample
2:	
3:	

## 3.6 Entering Numbers and Characters

### Entering Numbers

The operation to enter numbers is used such as when setting the date, time, and the display span of the input range.

#### Window for entering numbers

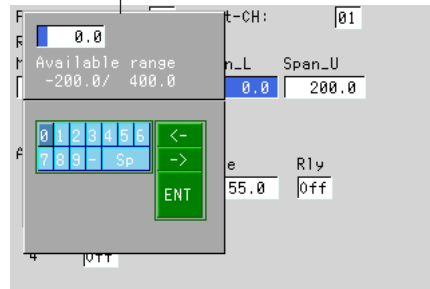

### Procedure

When the window used to enter the numbers appears, enter the value according to the following key operations.

#### Cursor (blue)

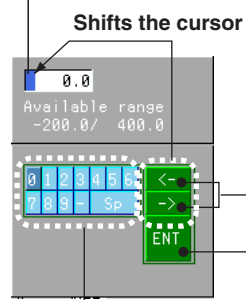

To shift the cursor to the left or right, select [ $\leftarrow$ ] or [ $\rightarrow$ ] using the arrow keys and press the DISP/ENTER key.

To confirm the number entered, select [ENT] using the arrow keys and press the DISP/ENTER key.

To enter a number, select the number using the arrow keys and press the DISP/ENTER key.

[ $-$ ]: Minus sign

[Sp]: Space

### Entering Characters

Used to set tag names, set message strings, set or enter passwords.

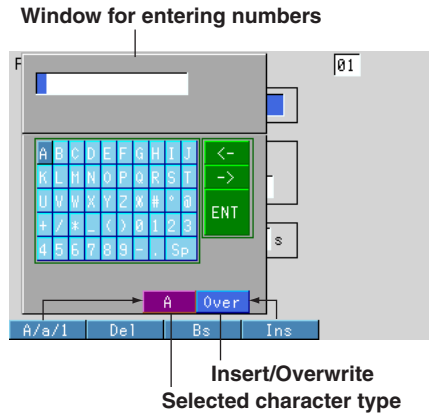

#### Procedure

When the window used to enter the string appears, enter the characters according to the following key operations.

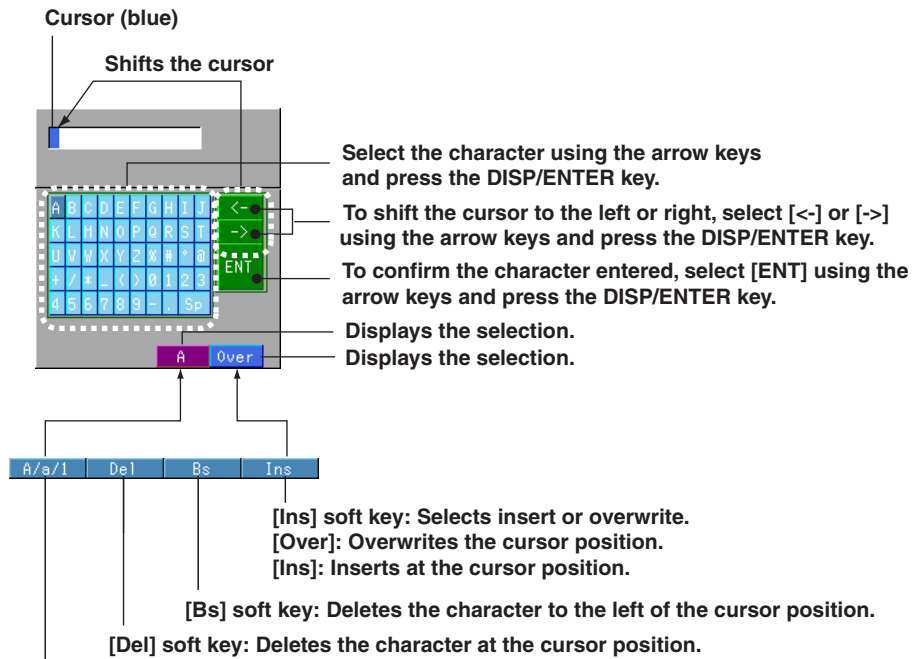

---

## 3.7 Using the Remote Control Terminal

### Handling Precautions

- If the infrared signal output section of the remote control terminal or the light-receiving section on the DX100P becomes dirty or receives scratches, it can hinder the transmission/reception of the infrared signal. Clean the infrared signal output section of the remote control terminal or the light-receiving section on the DX100P as necessary.
- When cleaning, wipe using a dry soft cloth. Do not use volatile chemicals since this might cause discoloring and deformation.
- Do not apply shock to the remote control terminal.
- Do not operate the remote control terminal with wet hands.
- The transmission/reception sensitivity of the infrared signal may deteriorate if used in the following types of locations.
  - Location where the light-receiving section of the DX100P is exposed to direct sunlight or fluorescent lamp.
  - Near magnetic field sources such as a transceiver.
- If you carry the remote control unit in your pocket, for example, keys may be pressed unintentionally and cause the DX100P or DX200P (herein after “the DXP”) to be controlled. Handle the remote control terminal properly so that keys are not pressed inadvertently.
- When you are near the DXP, press the keys on the remote control terminal only when controlling the DXP. Otherwise, you may unintentionally control the DXP (if you are going to press the keys on the remote control terminal but do not wish to control the DXP, take measures so that the signal does not reach the DXP such as by covering the infrared signal output section of the remote control terminal).
- The distance at which the DXP can be controlled using the remote control unit varies depending on the operating environment such as the battery voltage and the presence or absence of external light.
- There is a possibility that DXPs with the same remote controller ID be controlled simultaneously. It is recommended that different remote controller IDs be set on each instrument.

### Operation on the DX100P

#### Setting the remote controller ID

Set the remote controller ID of the DX100P. You can set a value between 0 and 31 or [Off] for the remote controller ID. For the setting procedure, see section 4.9.

#### Checking the remote controller ID

You can check the remote controller ID on the system screen. For the procedure for displaying the system screen, see section 8.9.

## Operation Using the Remote Control Terminal

### Names of parts

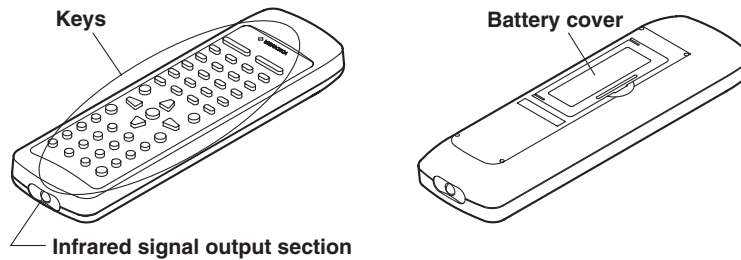

### Inserting batteries

1. While pressing the projection on the battery cover, open the cover.

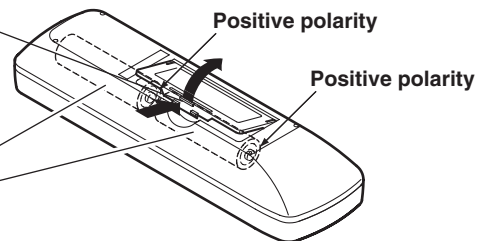

2. Insert the batteries.
3. Close the battery cover.

### Setting the ID number

Set the ID number (0 to 31) of the remote control terminal according to the procedure shown in the figure below. Set the ID number the same as the remote controller ID of the DX100P that you wish to control. The ID number of the remote control terminal is not displayed anywhere. If you are not sure which ID number the remote control terminal is set to, set the appropriate ID number again according to the following procedure.

1. Press ID.

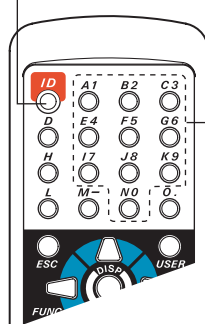

2. Enter the ID number (0 to 31) using the keys from 1 (A1) to 0 (N0).  
Example For ID number 16  
Operation: Press 1 (A1) and then 6 (G6).

3. Press ID.

### Note

- If you enter an ID number other than 0 through 31, the ID number retains the original setting.
- Pressing the ID key once causes the remote control terminal to enter the ID number setup mode. If none of the keys on the remote control terminal is pressed for 8 s, the remote control terminal automatically exits from the ID number setup mode. In this case, the ID number of the remote control terminal retains the original setting.
- If you remove the battery, the ID number is reset to 0. After inserting the battery, set the appropriate ID number again.

### Affixing the ID number label

If you are using the remote control terminal with a fixed ID number (such as when there is a one-to-one correspondence between the DX100P to be controlled and the remote control terminal), you can enter the ID number on the ID number label and affix the label on the remote control terminal.

### 3.7 Using the Remote Control Terminal

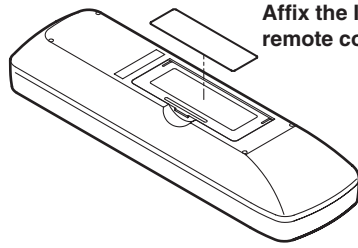

Affix the ID number label on the battery cover of the remote control terminal.

#### Controlling the DX100P

Control the DX100P by pointing the infrared signal output section of the remote control terminal to the light-receiving section on the DX100P. You can control the DX100P with a remote controller ID that is the same as the ID number of the remote control terminal. Control the DX100P while checking the results on the DX100P screen.

#### Note

- When a specific key operation is possible on the DX100P, the corresponding key on the remote control terminal is activated. For example, the operation for entering a character string is activated when a window for entering a character string is displayed on the DX100P screen.
- If another DXP with the same remote controller ID as the DX100P you wish to control exists in the range of the infrared signal of the remote control terminal, the two instruments may be controlled simultaneously.
- Pressing the ID key once causes the remote control terminal to enter the ID number setup mode. You cannot control the DX100P using the remote control terminal, if the remote control terminal is in the ID number setup mode. Pressing the ID key again causes the remote control terminal to exit the ID number setup mode. Or, if none of the keys on the remote control terminal is pressed for 8 s, the remote control terminal automatically exits from the ID number setup mode.

The keys in the following figure can be used to control the DX100P.

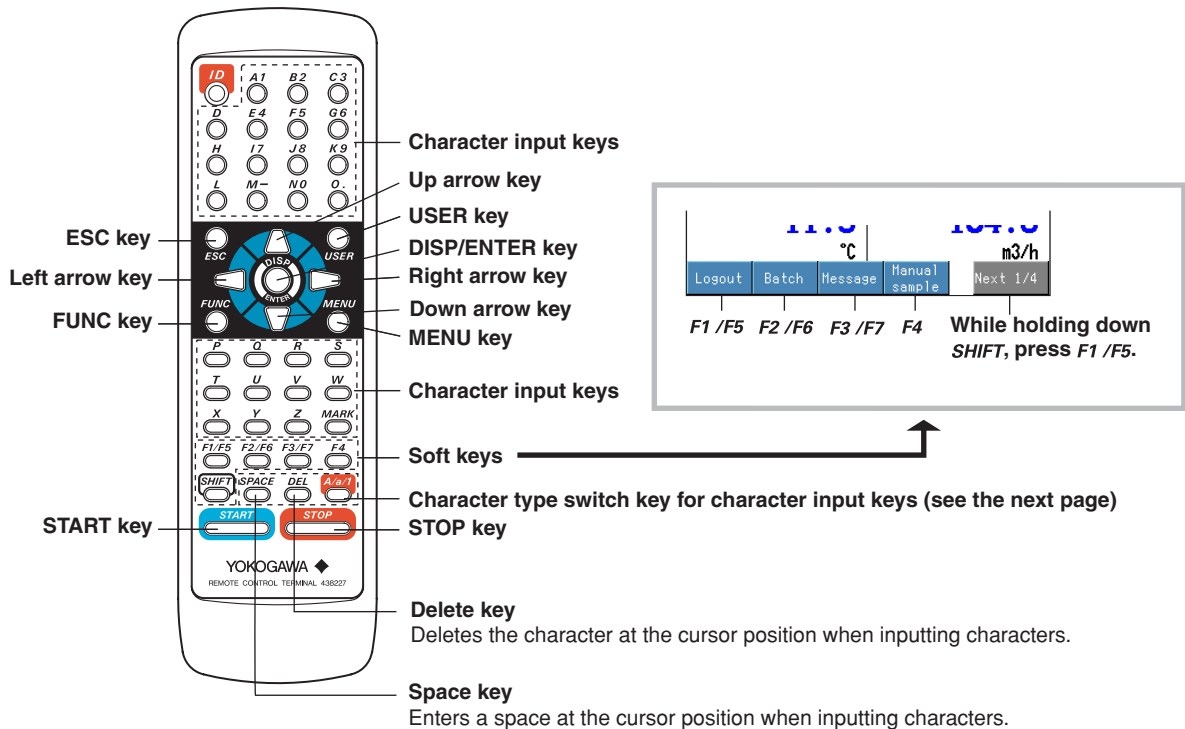

**Entering strings**

When entering strings on the remote control terminal (a window for entering a string is displayed on the DX100P screen), operate the terminal as follows (different from the key operation on the DX100P).

1. Press the left and right arrow keys to determine the character input position in the string entry box.
2. Use the character input keys, character type switch key (A/a/1, see the next page), DEL key, SPACE key and soft keys to enter the string.
3. To confirm the string that you entered, press the DISP/ENTER key. To cancel, press the ESC key.

**Note**

- When entering a string, the up and down arrow keys are disabled.
- On DX100P with the computation option (/M1), use the keys on the DX100P to enter the computing equation of the computation channel. Computing elements (such as "SQR(" and "TLOG.") are not assigned to the keys on the remote control terminal.

When a character input window is displayed on the DX100P screen, pressing the **A/a/1** key switches the character type assigned to the character input keys as shown in the following figure.

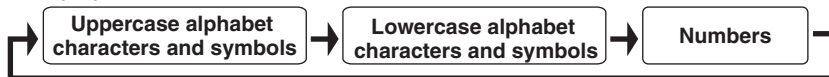

- **Uppercase alphabet characters and symbols/lowercase alphabet characters and symbols**

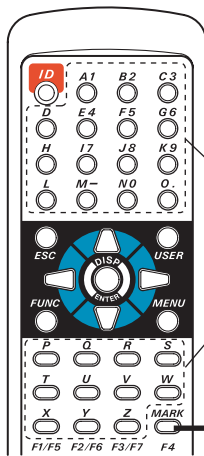

Alphabet (A to Z or a to z)

Each time the **MARK** key is pressed, the displayed symbol switches in the following order. The display switches in a cyclic pattern.

MARK key	Number of times the key is pressed									
	1	2	3	4	5	6	7	8	9	10
Symbol	%	#	°	@	_	( )	+	*	/	

- **Numbers**

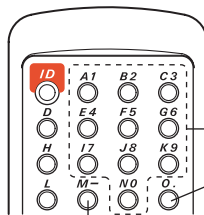

Number (1 to 9 and 0)

Decimal point

Minus sign

However, when setting a constant to be used in the computation on the DX100P with the computation option (/M1), the display switches in the order “.”, “+”, and “E” each time the key is pressed. The display switches in a cyclic pattern.

#### Troubleshooting

1. The DX100P does not react at all when you try to control it using the remote control terminal.
  - Check the voltage and the polarity of the batteries.
  - Check that the ID number of the remote control terminal matches the remote controller ID of the DX100P that you are trying to control.
  
2. The DX100P that could be controlled before cannot be controlled.
  - If the remote control terminal is in the ID number setup mode (condition in which the ID key is pressed once), the DX100P cannot be controlled using the remote control terminal. If none of the keys on the remote control terminal is pressed for 8 s, the remote control terminal automatically exits from the ID number setup mode.
  - Get closer to the DX100P. In addition, control the DX100P in front of the light-receiving section.
  - Replace the batteries with new ones.
  - Do not allow strong light to hit the light-receiving section of the DX100P.
  - Move magnetic field sources such as transceivers away from the system.
  - Clean the infrared signal output section of the remote control terminal or the light-receiving section on the DX100P.
  - Check whether the DX100P is in a condition that allows the operation, and start from an operation that can be performed.



# 4.1 Setting the Auxiliary Alarm Function

**Procedure**

For the detail of the auxiliary alarm function, see section 1.6.

Enter the system mode.

To display the setting screen press the soft key #1.

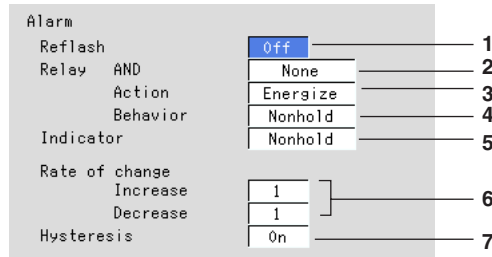

**Setting Reflash**

1. Reflash  
 [On]: Use reflash function.  
 [Off]: Not use reflash function

**Note**

If the reflash alarm is turned On, relays I01 to I03 operates as reflash alarms.

**Setting the AND/OR Logic of Output Relays**

2. Relay - AND  
 Select the relays that are to use the AND logic. Set the last relay that is to use the AND logic. The relays beyond this relay will use the OR logic.  
 Select from [None], [I01] (I01 only), [I01 - I02] (I01 and I02), ... , and [I01 - I06]. The setting is valid for relays specified by options.

**Note**

If the reflash alarm is turned On, relays I01 to I03 are set to OR logic. Specifying AND produces no effect.

**Setting the Output Relay Operation (Energize/De-energize)**

3. Relay - Action  
 [energize]: The output relay is energized when an alarm occurs  
 [de-energize]: The output relay is de-energized when an alarm occurs

**Setting the Output Relay Operation (Hold/Non-hold)**

4. Relay - Behavior  
 [non-hold]: Turn OFF the output relay in sync with the alarm release  
 [hold]: Hold the output relay ON till an alarm acknowledge operation is executed

**Note**

If the reflash alarm is turned On, relays I01 to I03 are set to non-hold. Specifying hold produces no effect.

\* When the alarm output relay option is not installed, these settings are void.

## 4.1 Setting the Auxiliary Alarm Function

---

### Setting the Alarm Indication Operation (Hold/Non-hold)

5. Indicator
  - [non-hold]: Release the alarm indicator in sync with the alarm release
  - [hold]: Hold the alarm indicator till an alarm acknowledge operation is executed

### **Note**

If the output relay operation is set to [hold], the alarm indication operation is [hold]. [non-hold] cannot be specified.

---

### Setting the Interval for the Rate-of-Change Alarm

6. Set the Increase (upper limit alarm) and Decrease (lower limit alarm) intervals for calculating the rate of change.  
The interval is the product of the setting value and the measurement interval.  
Select the limit from 1 to 15 using the soft key.

### Setting the Alarm Hysteresis

7. Hysteresis
  - Select [On] or [Off] using the soft key.
  - [On]: The hysteresis is 0.5% of the display span or scale.
  - [Off]: No hysteresis

### Confirming Operation

To confirm the new settings, press the DISP/ENTER key.

To cancel the new settings, press the ESC key. A window appears for you to confirm the cancellation. Select [Yes] using the arrow keys and press the DISP/ENTER key.

## 4.2 Setting the A/D Integration Time, Scan Interval, Burnout, Reference Junction Compensation, and Temperature Unit

### Procedure

Enter the system mode.

To display the setting screen press the soft key #2.

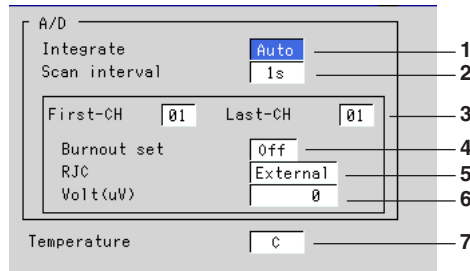

### Setting the Integration Time of the A/D Converter

#### 1. Integrate

Select the integration time of the A/D Converter.

DX102P/DX104P: Select [Auto], [50 Hz], or [60 Hz].

DX106P/DX112P: Select [Auto], [50 Hz], [60 Hz], or [100 ms].

[Auto]: automatically switches 20 ms and 16.7 ms (fixed to 20 ms on models that use the DC power supply)

[50 Hz]: fixed to 20 ms

[60 Hz]: fixed to 16.7 ms

[100 ms]: fixed to 100 ms (the scan interval is 2 s)

### Note

If the power supply frequency is different between the DX100P and the item being measured, set the integration time of the A/D converter to match the power supply frequency of the instrument that is generating more noise.

### Setting the Scan Interval

#### 2. Scan interval

Input signals are scanned at every scan interval. For the models with computation function (/M1), the computation carried out at every scan interval.

DX102P/DX104P: Select [125 ms] or [250 ms]

DX106P/DX112P: Select [1 s] or [2 s] (when the A/D integration time is 100 ms, the scan interval is fixed to [2 s].)

### Setting the Burnout Function for Thermocouple Input and Setting the Reference Junction Compensation

This setting is void for all input settings other than the TC.

#### 3. First channel and last channel

Select the desired channels.

#### 4. Burnout

Select [Off], [Up], or [Down].

[Off]: Disable the burnout detection function.

[Up]: When the thermocouple burns out, the measured result is set to positive over range “+\*\*\*\*\*.”

[Down]: When the thermocouple burns out, the measured result is set to negative over range “-\*\*\*\*\*.”

## **4.2 Setting the A/D Integration Time, Scan Interval, Burnout, Reference Junction... , and Temperature Unit**

5. RJC  
Select the reference junction compensation method from [External] and [Internal].  
[External]: Use the external RJC.  
[Internal]: Use the RJC of the DX100P.
6. Volt ( $\mu\text{V}$ )  
If [External] is selected, set the reference junction compensation voltage to add to the input.  
Pressing the [Input] soft key displays a window used to enter the voltage. Enter a value ( $-20000 \mu\text{V}$  to  $20000 \mu\text{V}$ , initial value is  $0 \mu\text{V}$ ) and press the DISP/ENTER key. For the procedures related to entering numerical values, see section 3.6, "Entering Numbers and Characters."

### **Setting the Temperature Unit**

7. Temperature Unit  
Select [C] or [F].  
[C]: Use Celsius.  
[F]: Use Fahrenheit.

### **Confirming Operation**

To confirm the new settings, press the DISP/ENTER key.

To cancel the new settings, press the ESC key. A window appears for you to confirm the cancellation. Select [Yes] using the arrow keys and press the DISP/ENTER key.

## 4.3 Setting the Method of the Display/Event Data Acquisition and Saving

Set the method of the display/event data acquisition. The waveforms of the specified channels can be displayed on the trend screen.

For the procedure of setting the cyclic use (Media FIFO) of the storage area of the external storage medium, see section 4.16.

### Procedure

Enter the system mode.

#### Setting the Type of Process/Action to Clear Waveform Display at Memory Start

To display the menu screen press the soft key .

To display the setting screen press the soft key .

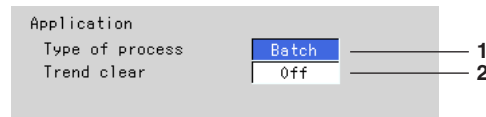

1. Application - Type of process  
Select [Batch] or [Continuous]. For information on [Batch] and [Continuous], see section 1.4.
2. Application - Trend clear  
Sets whether to clear the displayed waveform at Memory Start.  
[On]: Start after clearing the waveform display.  
[Off]: Start without clearing the waveform display.

#### Setting the Data Type to be acquired and saved

To display the menu screen press the soft key .

To display the setting screen press the soft key .

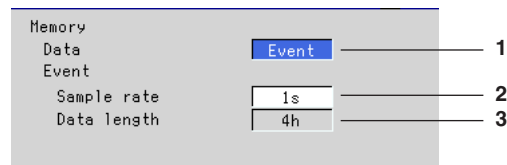

1. Data  
Select data type to be acquired. If [Event] is selected, [Sample rate] and [Data length] appears.  
[Display]: Acquire and save the display data  
[Event]: Acquire and save the event data.

#### Note

If you set the type of process to [Continue] and the [Data] to [Display], set the auto save interval of the display data (see section 5.6).

### 4.3 Setting the Method of the Display/Event Data Acquisition and Saving

2. Event - Sample rate  
Select the sampling interval for the event data. You cannot specify a sampling interval that is faster than the scan interval.  
DX102P, DX104P: 125 ms, 250 ms, 500 ms, 1 s, 2 s, 5 s, 10 s, 30 s, 60 s, 12 s, 300 s, and 600 s  
DX106P, DX112P: 1 s, 2 s, 5 s, 10 s, 30 s, 60 s, 120 s, 300 s, and 600 s
3. Event - Data length  
This is the interval for delimiting the event data in the internal memory and saving to the external storage medium. Use the soft key to select the interval (see "Explanation"). If [Type of process] is set to [Batch], the [Data length] is fixed to the maximum possible value. You cannot change this value.

#### Confirming Operation

To confirm the new settings, press the DISP/ENTER key.

To cancel the new settings, press the ESC key. A window appears for you to confirm the cancellation. Select [Yes] using the arrow keys and press the DISP/ENTER key.

#### Setting the Channels to Display the Trend and Acquire the Data

##### Setting the Data Saving Time (Memory Timeup)

To display the menu screen press the soft key

To display the setting screen press the soft key

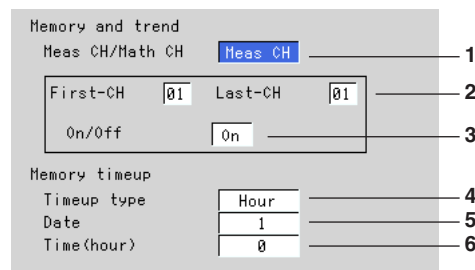

1. Meas CH/Math CH\*  
To set the measurement channels, select [Meas CH]. To set the computation channels, select [Math CH].  
\* [Math CH] appears only on models with the computation option (/M1).
2. First channel and last channel  
Select the desired channel numbers.
3. On/Off  
[On]: Display the trend/acquire data  
[Off]: Do not display the trend/do not acquire data  
The initial setting is [On] for all channels.

Repeat step 1 through 3 if necessary.

#### Confirming Operation

To confirm the new settings, press the DISP/ENTER key.

To cancel the new settings, press the ESC key. A window appears for you to confirm the cancellation. Select [Yes] using the arrow keys and press the DISP/ENTER key.

### Setting the Date/Time When Data Is To Be Saved (Memory Timeup)

When the date/time set here comes, the display data or the event data in the internal memory is delimited and saved to the external storage medium.

#### Note

If the type of process is "Batch" and a single batch data is divided into multiple files, you cannot sign the batch data using the DX100P. Use the DAQSIGNIN that came with the package to sign the data.

4. Timeup type  
Select the type of the time interval from [Hour], [Day], [Week], and [Month].  
If a setting other than [Off] is specified, [Date] or [Day of the week] and [Time(hour)] are displayed.  
[Off]: Disable this function.  
[Hour]: Saves the data in the internal memory to the external storage medium every hour on the hour.  
[Day]: Saves the data in the internal memory to the external storage medium every day at the hour on the hour specified by [Time(hour)].  
[Week]: Saves the data in the internal memory to the external storage medium at the day specified by [Day of the week] at the hour on the hour specified by [Time(hour)].  
[Month]: Saves the data in the internal memory to the external storage medium at the date specified by [Date] at the hour on the hour specified by [Time(hour)].
5. Date or Day of the week  
When [Timeup type] is set to [Hour], [Day], or [Month], [Date] is displayed. However, the [Date] setting is valid only when [Timeup type] is set to [Month]. Pressing the [Input] soft key displays a window used to enter the value. Enter the date (1-28)\* and press DISP/ENTER. For the procedures related to entering numerical values, see section 3.6, "Entering Numbers and Characters."  
\* You cannot specify 29, 30, or 31.  
  
When [Timeup type] is set to [Week], [Day of the week] is displayed. Enter the day of the week using the soft key.
6. Time(hour)  
Set the time when data is to be saved. This is invalid when [Timeup type] is set to [Hour].  
Enter the hour (00-23) using the same method as step 5.

### Confirming Operation

To confirm the new settings, press the DISP/ENTER key.

To cancel the new settings, press the ESC key. A window appears for you to confirm the cancellation. Select [Yes] using the arrow keys and press the DISP/ENTER key.

### 4.3 Setting the Method of the Display/Event Data Acquisition and Saving

#### Explanation

#### The Number of Measurement and Computation Channels Available in the Different Models

Model	Measurement Channel	Computation channel
DX102P	2 channels (1 and 2)	8 channels (31 to 38)
DX104P	4 channels (1 to 4)	8 channels (31 to 38)
DX106P	6 channels (1 to 6)	12 channels (31 to 42)
DX112P	12 channels (1 to 12)	12 channels (31 to 42)

#### Choices for the Data Length

The maximum value of the data length varies depending on the sampling interval and the number of measurement and computation channels to be acquired. The available choices for the data length from the table below are displayed on the soft key menu.

Sample rate (s)	0.125*	0.25*	0.5*	1	2	5	10	30	60	120	300	600
Data length (choices)	3 min	3 min	3 min	3 min	3 min							
	5 min	5 min	5 min	5 min	5 min							
	10 min	10 min	10 min	10 min	10 min	10 min	10 min					
	20 min	20 min	20 min	20 min	20 min	20 min	20 min					
	30 min	30 min	30 min	30 min	30 min	30 min	30 min					
	1 h	1 h	1 h	1 h	1 h	1 h	1 h	1 h	1 h	1 h	1 h	1 h
	2 h	2 h	2 h	2 h	2 h	2 h	2 h	2 h	2 h	2 h	2 h	2 h
	3 h	3 h	3 h	3 h	3 h	3 h	3 h	3 h	3 h	3 h	3 h	3 h
	4 h	4 h	4 h	4 h	4 h	4 h	4 h	4 h	4 h	4 h	4 h	4 h
	6 h	6 h	6 h	6 h	6 h	6 h	6 h	6 h	6 h	6 h	6 h	6 h
	8 h	8 h	8 h	8 h	8 h	8 h	8 h	8 h	8 h	8 h	8 h	8 h
	12 h	12 h	12 h	12 h	12 h	12 h	12 h	12 h	12 h	12 h	12 h	12 h
		1 day	1 day	1 day	1 day	1 day	1 day	1 day	1 day	1 day	1 day	1 day
			2 day	2 day	2 day	2 day	2 day	2 day	2 day	2 day	2 day	2 day
				3 day	3 day	3 day	3 day	3 day	3 day	3 day	3 day	3 day
				5 day	5 day	5 day	5 day	5 day	5 day	5 day	5 day	5 day
					7 day	7 day	7 day	7 day	7 day	7 day	7 day	7 day
					10 day	10 day	10 day	10 day	10 day	10 day	10 day	10 day
						14 day	14 day	14 day	14 day	14 day	14 day	14 day
							31 day	31 day	31 day	31 day	31 day	31 day

\* for DX102P and DX104P only



## 4.4 Registering Users and Setting the Login Function and Electronic Signature Function

When using the DX100P, first set the login function, electronic signature function, and administrators. Log in as the registered administrator to register users. See the flow chart on section 3.5.

### Note

The DX100P can be operated without logging in at the time of factory shipment.

### Procedures of Registering Users While Data Acquisition Is in Progress

See page 4-15.

### Setting the Login Function and Electronic Signature Function for the First Time

#### Procedure

Enter the system mode.

To display the menu screen press the soft key .

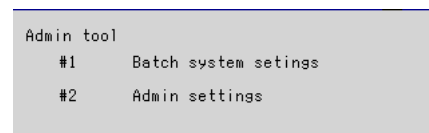

To display the setting screen press the soft key .

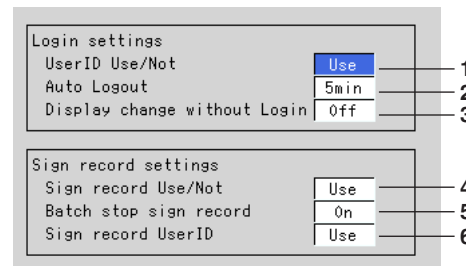

### Setting the Conditions for the Login Function

- User ID Use/Not**  
 [Use]: Enter an user ID when logging in.  
 [Not]: Not use an user ID when logging in.
- Auto logout**  
 Select the time period from [1 min], [2 min], [5 min], and [10 min]. The user who logged in is automatically logged out if there is no key operation for the specified time.  
 [Off]: The user stays logged on, until the user manually logs out.
- Display change without Login**  
 [On]: The operation screen can be switched using keys while logged out.  
 [Off]: The operation screen can not be switched using keys while logged out.

## 4.4 Registering Users and Setting the Login Function and Electronic Signature Function

### Setting the Conditions for the Electronic Signature Function

4. Sign record Use/Not  
[Use]: Use the electronic signature function.  
[Not]: Not use the electronic signature function.
5. Batch stop sign record  
[On]: When you execute Memory Stop, the sign record screen appears automatically.  
[Off]: When you execute Memory Stop, the sign record screen does not appear.

#### Note

The [Batch stop sign record] setting is invalid in the following cases.

- If the type of process is [Batch] and a single batch data is divided into multiple files.
- When a user who is not allowed to sign executed Memory Stop.

6. Sign record User ID  
[Use]: Use an user ID when signing.  
[Not]: Not use an user ID when signing.

### Confirming Operation

To confirm the new settings, press the DISP/ENTER key.

To cancel the new settings, press the ESC key. A window appears for you to confirm the cancellation. Select [Yes] using the arrow keys and press the DISP/ENTER key.

## Registering an Administrator

#### Note

It is recommended that two or more administrators be registered. If one administrator fails to log in due to erroneous input of the password, the other administrator can fix the registration.

Display the [Admin tool] menu (see the previous page).

To display the setting screen press the soft key #2.

Admin settings		
Number	3	1
Login method	Key+Com	2
User name		3
User ID		4
Password	????????	5
Password expire	Off	6

1. Number  
Select the number used to identify the administrator from 1, 2, and 3.
2. Login method  
[Off]: Disables the administrator.  
[Key]: Enables to login through key operations on the DX100P.  
[Key+Com]: Enables to login through key operations on the DX100P and via communications.

## 4.4 Registering Users and Setting the Login Function and Electronic Signature Function

### 3. User name

Pressing the [Input] soft key displays a window used to enter a string. Enter the user name (up to 20 characters), and press the DISP/ENTER key.

For the procedure related to entering values and strings, see section 3.6, "Entering Numbers and Characters."

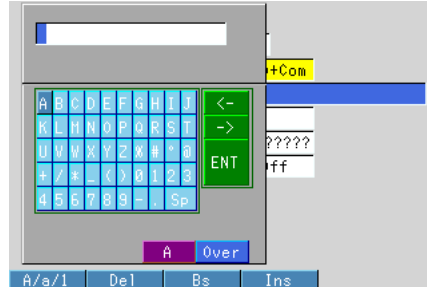

#### Note

- You cannot register user names that are already registered.
- You cannot specify "quit" as a user name. In addition, character strings that include a space or spaces are not allowed.

### 4. User ID

Pressing the [Input] soft key displays a window used to enter the user ID. Enter the user ID (up to 8 numbers), and press the DISP/ENTER key.

For the procedure related to entering values and strings, see section 3.6, "Entering Numbers and Characters."

### 5. Password

[????? ? ? ?]: The default password for the DX100P is set. The password cannot be changed. For details on the default password, see section 6.1.

[\*\*\*\*\*]: The password that the user actually uses is set. To change to the default password, press the [Default] soft key.

[-----]: User Locked condition. To clear the User Locked condition, press the [Default] soft key to set the default password.

#### Note

- The password that is actually used is set when the user logs in for the first time.
- If the user name or user ID is changed, the password is reset to the default password.

### 6. Password expire

If the specified time elapses, you will be requested to change the password.

Select the time period from [1month] (1 month), [3month] (3 months), and [6month] (6 months).

[Off]: Not set a password expiration period.

#### Confirming Operation

To confirm the new settings, press the DISP/ENTER key.

To cancel the new settings, press the ESC key. A window appears for you to confirm the cancellation. Select [Yes] using the arrow keys and press the DISP/ENTER key.

### Registering Users

Enter the system mode.

To display the menu screen press the soft key .

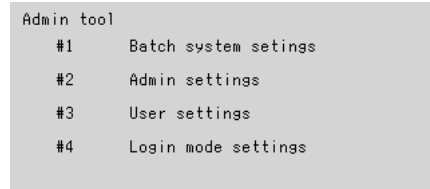

To display the [User number] screen press the soft key .

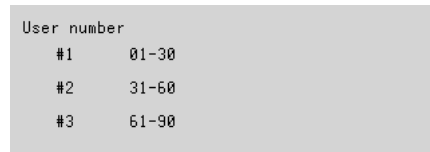

To display the setting screen press the soft key , , or .

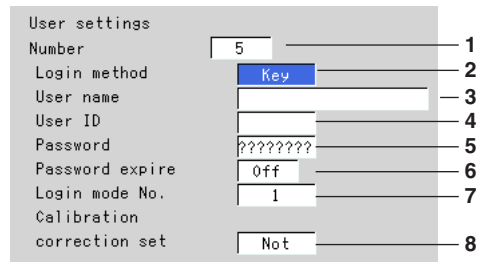

1. Number  
Number used to identify the user. Select a number from 1 to 30, 31 to 60, or 61 to 90.
2. Login method  
[Off]: Disables the user.  
[Key]: Enables to login through key operations on the DX100P.  
[Com]: Enables to login via communications.  
[Key+Com]: Enables to login through key operations on the DX100P and via communications.
3. User name  
See the section "User name" in "Registering an Administrator."
4. User ID  
See the section "User ID" in "Registering an Administrator."
5. Password  
See the section "Password" in "Registering an Administrator."
6. Password expire  
See the section "Password expire" in "Registering an Administrator."
7. Login mode number  
Set the number (1 to 30) of the login mode to be applied. The login mode is set in the section followed.

8. Calibration correction set

This item is displayed when the calibration correction (/CC1) is equipped.

[Use]: You can change the segments for calibration correction<sup>\*1</sup>.

[Not]: You cannot change the segments for calibration correction<sup>\*1</sup> or the range of the measurement channel<sup>\*2</sup>.

\*1 Items in section 5.21

\*2 Items in section 5.1. Cannot be changed because changing the range of the measurement channel may affect the calibration correction.

**Confirming Operation**

To confirm the new settings, press the DISP/ENTER key.

To cancel the new settings, press the ESC key. A window appears for you to confirm the cancellation. Select [Yes] using the arrow keys and press the DISP/ENTER key.

**Explanation**

**Calibration correction set**

Sets whether to allow the changing of the segments for calibration correction when the calibration correction (/CC1) option is installed. Below are the items that can be specified depending on this setting and the [MENU] setting in the next section, "Setting the Login Mode."

MENU (Login mode) Calibration correction set	Lock	Free
Use	You can only specify calibration correction settings.	You can specify all Engineering Mode settings.
Not	You cannot specify Engineering Mode settings.	You can specify Engineering Mode settings excluding the range setting of the measurement channel and the calibration correction setting.

**Setting the Login Mode**

Display the [Admin tool] menu (see the previous page).

To display the setting screen press the soft key #4.

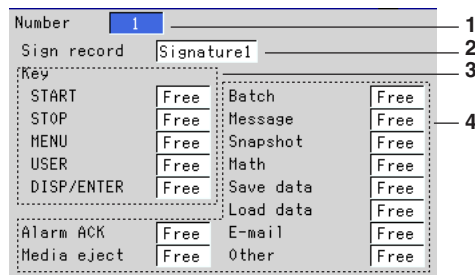

1. Number  
Login mode number. Select a number from 1 to 30.
2. Sign record  
Select from the three sign authority levels (Sign1, Sign2, and Sign3) or [Off].  
[Off]: Signing to data is not permitted.

#### 4.4 Registering Users and Setting the Login Function and Electronic Signature Function

---

3. Key  
 Set whether to enable the operation.  
 [Free]: Enable  
 [Lock]: Disable

Symbol	Operation When "Lock" Is Specified
START	The START key does not operate.
STOP	The STOP key does not operate.
MENU	The MENU key does not operate.
USER	The USER key does not operate.
DISP/ENTER	The DISP/ENTER key does not operate in the operation mode (except, the key operates on the sign record screen). The DISP/ENTER key operates in the engineering mode.

4. Alarm ACK, Media, Batch, ..., Other  
 Set whether to enable the operation.  
 [Free]: Enable  
 [Lock]: Disable

Symbol	Operation When "Lock" Is Specified
Alarm ACK	Alarm ACK operation on the overview screen and Alarm ACK operation by the USER key are not allowed.
Media	Zip disk eject operation is not allowed (on the models with the Zip disk drive).
Batch	[Batch] soft key is not displayed.
Message	[Message] soft key is not displayed. Message writing by the USER key does not operate.
Snapshot	[Snapshot] soft key is not displayed. Snapshot by the USER key does not operate.
Math	[Math START], [Math STOP], [Math reset], and [Math ACK] soft keys are not displayed. [Math START], [Math STOP], and [Math reset] operations by the USER key do not operate.
Data save	[Display data save], [Event data save], and [Manual Sample] soft keys are not displayed. Manual sampling by the USER key does not operate.
Data load	[Display data load], [Event data load] soft keys are not displayed.
E-mail	[Mail START], [Mail STOP], [Mail transmission test] soft keys are not displayed.
Others	[4 screen], [Log], [FTP test], [MODBUS master], and [File list] soft keys are not displayed.

#### Confirming Operation

To confirm the new settings, press the DISP/ENTER key.

To cancel the new settings, press the ESC key. A window appears for you to confirm the cancellation. Select [Yes] using the arrow keys and press the DISP/ENTER key.

### Registering Users When Data Acquisition Is in Progress

This operation applies when data acquisition is in progress in the operation mode.

- Only an administrator can carry out this operation.
- The operation must be enabled in the settings. For the setup procedure, see section 4.14.

**Note**

You cannot change settings of users that are logged in.

**Procedure**

Press . The engineering mode menu appears.

Only the enabled items appear in the menu.

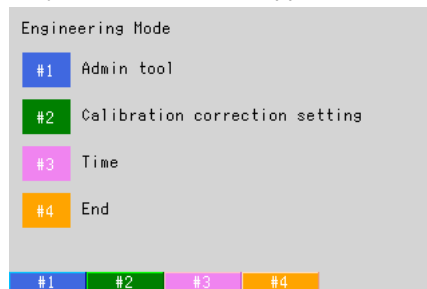

Press [Admin tool] soft key. The menu screen is displayed.

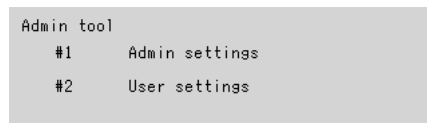

**Registering an Administrator**

Press the  (Admin settings) soft key. The setup screen is displayed.

For the rest of the procedure, see “Registering an Administrator” on page 4-10.

**Registering Users**

Press the  (User settings) soft key. The setup screen is displayed.

For the rest of the procedure, see “Registering Users” on page 4-12.

## 4.5 Assigning Actions to the Remote Control Terminals (/R1 Option)

### Procedure

Enter the system mode.

Press the soft key .

To display the menu screen press the soft key .

To display the setting screen press the soft key .

No.	Action
1	None
2	None
3	None
4	None
5	None
6	None
7	None
8	None

#### 1. Action

Select the [Action] box using the arrow keys and select actions for the terminals 1 to 8.

### Confirming Operation

To confirm the new settings, press the DISP/ENTER key.

To cancel the new settings, press the ESC key. A window appears for you to confirm the cancellation. Select [Yes] using the arrow keys and press the DISP/ENTER key.

### Explanation

#### Actions That Can be Assigned

Enclosed in parentheses are soft key expressions. For details of actions, see section 1.9.

- No action is assigned: [None]
- Memory Start/Memory Stop: [StartStop]
- Releasing the alarm indication and output relay: [AlarmACK]
- Adjusting the internal clock: [Time adj]
- Starts/stops computation (option): [Math]
- Clears computed results (option): [Math rst]
- Manual sampling: [M.sample]
- Writing messages: [Message1] to [Message8]  
The messages 1 to 8 of the message group 7 (see section 5.16) can be assigned to the remote control input to be written.
- Snap shot: [Snapshot]



## 4.6 Setting the Report Function

### Procedure

Enter the system mode.

Press the soft key .

To display the menu screen press the soft key .

To display the setting screen press the soft key .

Report		
Report set	Hour	1
Date	1	2
Time	0	3
Report CH	R01	4
On/off	On	5
Channel	01	6
Sum scale	/s	7

- Report set (see page 1-45)
  - [Hour]: Creates hourly reports.
  - [Day]: Creates daily reports.
  - [Hour+Day]: Creates hourly and daily reports.
  - [Day+Week]: Creates daily and weekly reports.
  - [Day+Month]: Creates daily and monthly reports.
- Date/Day of the week
 

This is the date or day of the week on which the report is created.

If the [Report set] is set to [Day+Month], [Date] is displayed. If [Day+Week] is specified, [Day] is displayed. If [Hour], [Day], or [Hour+Day] is specified, [Date] is displayed. However, this setting is void.

  - Date (for monthly reports)
 

Pressing the [Input] soft key or one of the character/number input keys displays a window used to enter the date. Enter the date (01-28)\* and press the DISP/ENTER key. For the procedures related to entering character strings, see section 3.6, "Entering Numbers and Characters."

\* You cannot specify 29, 30 or 31.
  - Day (for weekly reports)
 

Enter the day of the week using the soft key.
- Time (hour)
 

Set the time to create daily, weekly, and monthly reports with the time on the hour (00 to 23).

Enter the time using the same method as step 2.

This setting is void for hourly reports.
- Report CH
 

Select the report channel (R01 to R12) to which the measurement/computation channel is assigned. The reports are output in order according to this number.

## 4.6 Setting the Report Function

---

5. On/Off  
Select whether to use the selected report channel or not. If [Off] is selected, the report channel and the data are not output.  
[On]: Use the report channel.  
[Off]: Do not use the report channel.
6. Channel  
Set the measurement or computation channel to assign to the report channel. All measurement and computation channels can be specified. However, the reports are not created for the measurement channels that are set to [Skip] and the computation channels that are turned [Off].
7. Sum scale (sum unit)  
Select the method to determine the sum value from [Off], [/s], [/min], [/h], and [/day]. For details on the sum scale, see section 1.7.

### Confirming Operation

To confirm the new settings, press the DISP/ENTER key.

To cancel the new settings, press the ESC key. A window appears for you to confirm the cancellation. Select [Yes] using the arrow keys and press the DISP/ENTER key.

## 4.7 Setting the Timer for TLOG Data Acquisition and TLOG Computation

The timers specified here are used to determine the interval for the TLOG data acquisition (see page 1-26) and the TLOG computation (see page 1-46). Up to three timers can be specified.

### Procedure

Enter the system mode.

Press the soft key Next.

To display the menu screen press the soft key #7.

To display the setting screen press the soft key #3.

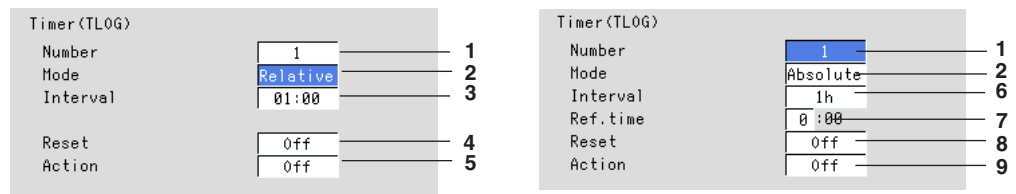

1. Mode  
Select the desired timer number.

### Setting the Relative Timer

2. Mode  
Select [Relative]. [Interval], [Reset], and [Action] are displayed.
3. Interval  
Set the interval the timer expires.  
Pressing the [Input] soft key displays a window used to enter the time. Enter the time (00:01 to 24:00) and press the DISP/ENTER key. For the procedures related to entering numerical values, see 3.6, "Entering Numbers and Characters."
4. Reset  
For the computation channel that TLOG computation is set, select whether or not to reset the computed data at every interval.  
[On]: Reset the computed data at every interval.  
[Off]: Do not reset the computed data.
5. Action  
[DataSave]: The measured/computed data (instantaneous values) of all measurement/computation channels is acquired to the internal memory and saved to the external storage medium at specified intervals (TLOG data saving).  
[Off]: TLOG data is not saved.

## 4.7 Setting the Timer for TLOG Data Acquisition and TLOG Computation

---

### Setting the Absolute Timer

2. Mode  
Select [Absolute]. [Interval], [Reset], [Ref. time], and [Action] are displayed.
6. Interval  
Select the interval to determine the time the timer expires from 19 choices below. 1 min, 2 min, 3 min, 4 min, 5 min, 6 min, 10 min, 12 min, 15 min, 20 min, 30 min, 1 h, 2 h, 3 h, 4 h, 6 h, 8 h, 12 h, 24 h.
7. Ref. time  
Set the reference time to determine the time the timer expires.  
Pressing the [Input] soft key or one of the character/number input keys displays a window used to enter the time. Enter the time on the hour (00 to 23), and press the DISP/ENTER key. For the procedures related to entering numerical values, see 3.6, "Entering Numbers and Characters."
8. Reset  
For the computation channel that TLOG computation is set, select whether or not to reset the computed data at every interval.  
[On]: Reset the computed data at every interval.  
[Off]: Do not reset the computed data.
9. Action  
[DataSave]: The measured/computed data (instantaneous values) of all measurement/computation channels is acquired to the internal memory and saved to the external storage medium at specified intervals (TLOG data saving).  
[Off]: TLOG data is not saved.

### Confirming Operation

To confirm the new settings, press the DISP/ENTER key.

To cancel the new settings, press the ESC key. A window appears for you to confirm the cancellation. Select [Yes] using the arrow keys and press the DISP/ENTER key.

## 4.8 Setting System Relays (/F1 Option)

### Procedure

Enter the system mode.

Press the soft key .

To display the menu screen press the soft key .

To display the setting screen press the soft key .

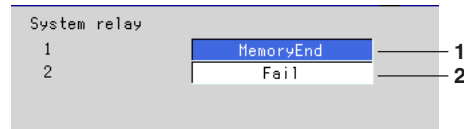

- 1 (Relay 1)  
Select the relay using the up and down arrow keys and select the output you wish to assign to relay 1.  
[FAIL]: CPU failure  
[Memory end]: Memory end  
[Batch]: Memory start/stop  
[User locked]: Occurrence of a user locked condition  
[Login user]: Presence of login users  
For details on the behavior, see section 1.8.
- 2 (Relay 2)  
Assign an output to relay 2 using the same method as for relay 1.

### Confirming Operation

To confirm the new settings, press the DISP/ENTER key.

To cancel the new settings, press the ESC key. A window appears for you to confirm the cancellation. Select [Yes] using the arrow keys and press the DISP/ENTER key.

## 4.9 Setting the Auxiliary Functions

Select whether tag names or channel numbers are to be displayed on the operation screen (trend screen, digital screen, etc.). The initial setting is “channel number display.” Tag names are set in the engineering mode (see section 5.3).

When the remaining time for storing the display or event data in the internal memory falls to the specified time (Memory alarm time), an alarm is generated via e-mail or the relay contact output (/F1 option). For details related to the relay output action, see section 1.8.

Select the display language.

Set whether or not to use the partial expanded display. The display specifications of the partial expanded display are set in the engineering mode (see section 5.11).

Set the remote controller ID (Easy text entry (/KB1, /KB2) option).

### Procedure

Enter the system mode.

Press the soft key Next.

To display the setting screen press the soft key #5.

AUX		
Tag/Channel	<span style="border: 1px solid black; padding: 2px;">Channel</span>	1
Memory alarm	1h	2
Language	English	3
Partial	Not	4
Remote Controller ID	Off	5

1. Tag/Channel  
Select [Tag] or [Channel].  
[Tag]: Display tag names.  
[Channel]: Display channel numbers.

### Note

Even if [Tag] is selected, the channel number display will be used for the channels that tag names are not entered.

2. Memory alarm  
Select the remaining write time of the internal memory at which the relay should be activated from [1 h], [2 h], [5 h], [10 h], [20 h], [50 h], [100 h], and [Off]. The initial setting is [1 h].  
[Off]: Memory end output function is disabled (the free space of the external storage medium is not checked either (see section 1.8)).
3. Language  
Select the display language.
4. Partial  
[Use]: Use the partial expanded display. The partial expanded display can be set in the engineering mode.  
[Not]: Do not use the partial expanded display.

5. Remote Controller ID

This item is for the easy text entry option (/KB and /KB2).

Select the remote controller ID from 0 to 31 or [Off].

[Off]: Do not operate the DX100P using the remote control terminal.

**Confirming Operation**

To confirm the new settings, press the DISP/ENTER key.

To cancel the new settings, press the ESC key. A window appears for you to confirm the cancellation. Select [Yes] using the arrow keys and press the DISP/ENTER key.

## 4.10 Setting the Time Zone

Set the time difference from GMT (Greenwich Mean Time). If you use the DST function or the Web server function, make sure to set this parameter.

### Procedure

Enter the system mode.

Twice press the soft key .

To display the setting screen press the soft key .

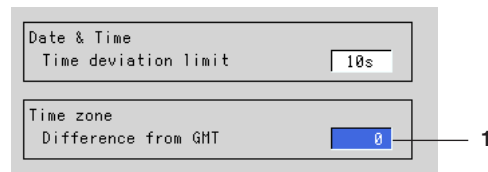

#### 1. Difference from GMT

Pressing the [Input] soft key or one of the character/number input keys displays a window used to enter the time difference. Enter the value (–1200 to 1200 (upper two digits: hours, lower two digits: minutes)) and press the DISP/ENTER key. For the procedures related to entering numerical values, see 3.6, “Entering Numbers and Characters.”

**Example:** If the local time leads 9 hours to GMT, set “900.”

### Confirming Operation

To confirm the new settings, press the DISP/ENTER key.

To cancel the new settings, press the ESC key. A window appears for you to confirm the cancellation. Select [Yes] using the arrow keys and press the DISP/ENTER key.



## 4.11 Saving/Loading Setup Data

### Saving Setup Data

Saves the setup data of the engineering and system modes (including the login information) to the external storage medium.

#### Procedure

Enter the system mode.

Press the soft key .

Press  soft key to display the [Save/Load, Clear data] menu screen.

Press  soft key to display the [Save settings] screen.

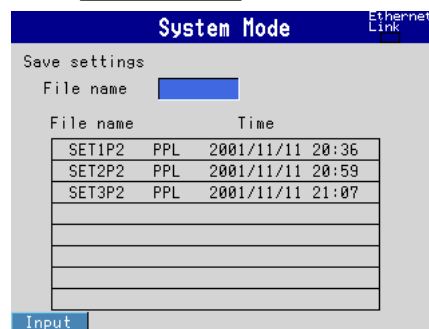

1. Enter the file name in the [File name] box (up to eight characters) and press the DISP/ENTER key.  
For the procedures related to entering strings see 3.6, "Entering Numbers and Characters."  
Press the ESC key to cancel the operation and return to the [Save/Load, Initialize] menu.

#### Note

- Setup data file is automatically assigned .PPL extension.
- The following characters or strings cannot be used as file names.  
"AUX," "CON," "PRN," "NUL," "CLOCK," character strings that include a space or spaces

2. Press the DISP/ENTER key to save the setup data to the root directory of the external storage medium. The saved file is displayed in the file list section on the right side.  
If a file with the same name as you entered exists on the external storage medium, a message will appear to confirm overwriting. To overwrite the file, select [Yes] and press the DISP/ENTER key.

## 4.11 Saving/Loading Setup Data

### Loading Setup Data

Loads the data excluding the login information from the setup file (file with .PPL extension) on the external storage medium to the DX100P. When executed, the loaded data are activated, and the user is logged out.

#### Procedure

Enter the system mode.

Press the soft key Next.

Press #6 soft key to display the [Save/Load, Clear data] menu screen.

Press #2 soft key to display the [Load settings] screen.

System Mode		
Load settings		
Directory	File name	Time
/	Y1121111 PPL	2001/11/11 21:11
SET0	Y1121371 PPL	2001/11/11 21:38
DATA0		
<span style="border: 1px solid black; padding: 2px;">Details</span>		

- Using the up and down arrow keys, select the directory (root directory [/] or SET0) containing the setup file shown in the [Directory name] box. A list of files in the selected directory is displayed in the right column.
- Press the right arrow key to move the cursor on to the file list. Press the up or down arrow key to select the setup file to be loaded. Press the ESC key to cancel the operation and return to the [Save/Load, Initialize] menu.
- Press the [Details] soft key to view the information about the file.

File name	: 80307151.PPL	File name
Damage check	: Not damaged	Damage check
Save kind	: Change settings	Damaged: File damaged, data tampered, etc.
File number	: 8	Save type
Save time	: Dec. 28. 20/* *x:11:00	Save settings: File saved through save settings operation.
User name	: ABC2001	Change settings: File saved when settings were changed.

**File number**  
A sequence number assigned in the order of occurrence when "Save type" is "Change settings" (identical to the number in the setting change log file. See "Audit Trail Function" in section 1.5)

**Date and time the file was saved**

**Name of the user who saved the file**

4. Press the DISP/ENTER key. The loaded setup data is activated, and the user is logged out.

**When the loaded setup data is different from the setup data of the DX100P, the setup file is saved to the external storage medium and the log of setting change is recorded in the setting change log** (audit trail function, see section 1.5).

**Note**

---

- If the file is [Damaged], the setup data cannot be loaded from the file.
  - If the loaded setup data are void, check the error log. For the procedure for displaying the error log, see section 8.9.
-

## 4.12 Loading the Login Information

This operation loads only the login information from the setup file (file with .PPL extension) on the external storage medium and uses it as the login information of the DX100P.

When this operation is executed, the user is logged out.

### Procedure

Enter the system mode.

Press the soft key .

Press  soft key to display the [Save/Load, Clear data] menu screen.

Press  soft key to display the [Load login settings] screen.

Directory	File name	Time
/	SET2P2 PPL	2001/11/11 20:59
SET0	SET3P2 PPL	2001/11/11 21:07
DATA1	SET4P2 PPL	2001/11/11 21:14
DATA0	SET1P2 PPL	2001/11/11 20:36

1. Using the up and down arrow keys, select the directory (root directory [/] or SET0) containing the setup file shown in the [Directory] box. A list of files in the selected directory is displayed in the right column.
2. Press the right arrow key to move the cursor on to the file list. Press the up or down arrow key to select the setup file to be loaded. Press the ESC key to cancel the operation and return to the [Save/Load, Initialize] menu.
3. Press the [Details] soft key to view the information about the setup file. For a display example, see page 4-23. Press the ESC key to clear the window displaying the information.
4. Press the DISP/ENTER key. The loaded login information is activated and the user is logged out.

### Note

- If the loaded login information differs from that of the DX100P, the setup file is saved to the external storage medium and a log of the setting change is recorded to the setting change log file (Audit trail function, see section 1.5).
- When login information is loaded, the passwords of all administrators and users are reset to their default passwords (see section 6.1). Set the password according to the procedure "Logging in for the First Time."
- If the file is [Damaged], the login information cannot be loaded from the file.

## 4.13 Clearing the Data in the Internal Memory and Initializing the Setup Data

You can initialize the setup data of the DX100P. At the same time, the measured/computed data (display data, event data, manual sample data, TLOG data (optional function), report data (optional function)), and logs in the internal memory can be cleared.

When this operation is executed, the user is logged out.

For the initial values of settings, see appendix 1.

### Procedure

Enter the system mode.

Press the soft key .

Press  soft key to display the [Save/Load, Initialize] menu screen.

Press  soft key to display the [Initialize] screen.

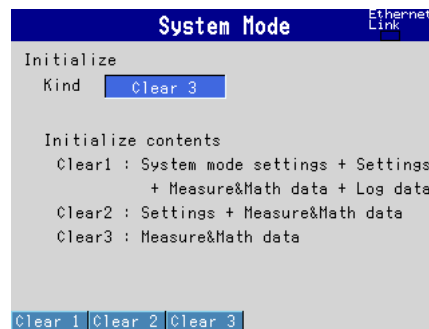

1. Select the type of initialization.

Use the soft keys to select the initialization type form [Clear 1], [Clear 2], and [Clear 3]. Press the ESC key to cancel the operation and return to the menu.

[Clear 1]: Initializes the setup data of the system mode and engineering mode and clears the measured/computed data and logs in the internal memory. However, the following system mode items (the login information) are not initialized (see section 4.4).

- Batch system settings
- Administrator settings
- User settings
- Login mode settings

[Clear 2]: Initializes the setup data of the engineering mode and clears the measured/computed data in the internal memory.

[Clear 3]: Clears the measured/computed data in the internal memory.

2. Press the DISP/ENTER key. A confirmation window is displayed. Select [Yes] and press the DISP/ENTER key to execute the initialization. The user is logged out.

### Note

If settings are changed on the DX100P through the [Clear 1] or [Clear 2] operation, the setup file is saved to the external storage medium and the log of the setting change is recorded to the setting change log file (Audit trail function, see section 1.5).

## 4.14 Setting Items That Are Allowed to Be Changed While Data Acquisition Is in Progress

### Procedure

Enter the system mode.

Twice press the soft key .

Press the  (Active storage change) soft key. The menu screen is displayed.

Active storage changes	
Time change	<input type="text" value="On"/> 1
User change	<input type="text" value="On"/> 2
Cal correct change	<input type="text" value="On"/> 3
Text message on cal correct	<input type="text" value="On"/> 4

1. Time change  
[On]: The time on the DX100P can be changed while data acquisition is in progress.  
[Off]: The time cannot be changed while data acquisition is in progress.
2. User change  
[On]: Users can be registered while data acquisition is in progress.  
[Off]: Users cannot be registered while data acquisition is in progress.
3. Cal correct change  
[On]: The segments for calibration correction can be specified while data acquisition is in progress.  
[Off]: The segments for calibration correction cannot be specified while data acquisition is in progress.
4. Text message on cal correct  
Displayed only when Cal correct change is set to On in step 3.  
[On]: A message is written when there is a change in the calibration correction setting while data acquisition is in progress (see "Explanation").  
[Off]: A message is not written even when there is a change in the calibration correction setting while data acquisition is in progress.

### Confirming Operation

To confirm the new settings, press the DISP/ENTER key.

To cancel the new settings, press the ESC key. A window appears for you to confirm the cancellation. Select [Yes] using the arrow keys and press the DISP/ENTER key.

### Explanation

#### Text message on cal correct

"Cal Correct Setting" is the message that appears when the calibration correction setting is changed while data acquisition is in progress. The message is displayed in purple on the trend display and recorded in the message summary.

## 4.15 Setting the Time Deviation Limit for Time Correction

Set the maximum value of time deviation between the time on the DX100P and the new time when changing the time while data acquisition is in progress. For a description of this function, see section 1.10.

### Procedure

Enter the system mode.

Twice press the soft key .

Press the  (Date & Time, Time Zone) soft key. The setup screen is displayed.

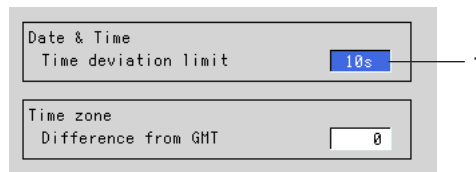

1. Time deviation limit  
Select [Off], [10s], [20s], [30s], [1min], [2min], [3min], [4min], or [5min].  
When the time deviation between the time on the DX100P and the specified time is within  $\pm$ (the value specified here), the time on the DX100P is gradually corrected. Otherwise, the time is not corrected.  
[Off]: The time cannot be changed while data acquisition is in progress.

Example: If [Time deviation limit] is set to [10s] and the time on the DX100P is 10 hours 21 minutes 15 seconds, the time on the DX100P is corrected if the specified time is between 10 hours 21 minutes 5 seconds and 10 hours 21 minutes 25 seconds.

### Confirming Operation

To confirm the new settings, press the DISP/ENTER key.

To cancel the new settings, press the ESC key. A window appears for you to confirm the cancellation. Select [Yes] using the arrow keys and press the DISP/ENTER key.

## 4.16 Using the Storage Area of the External Storage Medium Cyclically (FIFO Operation of the Storage Media)

Set the storage method that retains the specified number of the newest files in the storage area of the external storage medium. For a description of this function, see section 1.4.

### Procedure

Enter the system mode.

Press the soft key .

Press the  (AUX, Media FIFO) soft key. The setup screen is displayed.

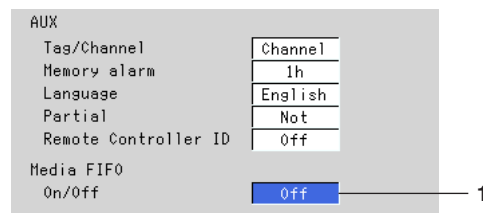

1. Media FIFO

[On]: Uses the storage area of the external storage medium cyclically.

[Off]: Does not use the storage area of the external storage medium cyclically.

### Confirming Operation

To confirm the new settings, press the DISP/ENTER key.

To cancel the new settings, press the ESC key. A window appears for you to confirm the cancellation. Select [Yes] using the arrow keys and press the DISP/ENTER key.



# 5.1 Setting Measuring Range

**Note**

On models with the calibration correction (/CC1) option, users who are not allowed to set the calibration correction cannot set the measuring range either.

**Procedure**

Press .

To display the setting screen press the soft key #1.

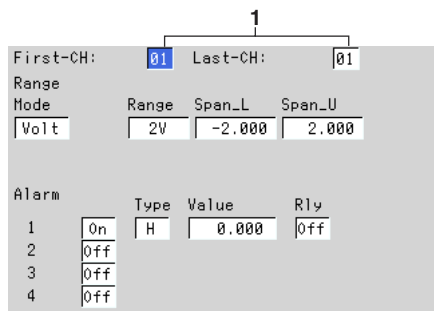

The setting items varies depending on the selected [Mode].

- **DC Voltage, Thermocouple, RTD, or Digital Input**

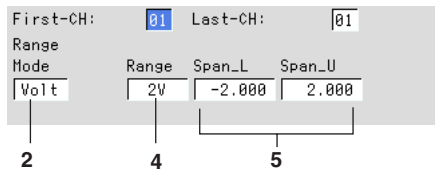

- **Difference**

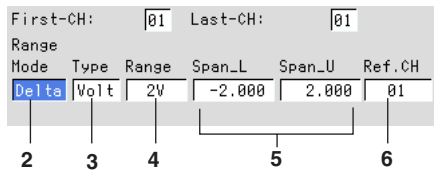

- **Scaling, Square Root**

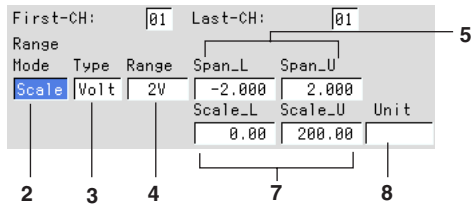

## 5.1 Setting Measuring Range

---

1. First-CH, Last-CH  
Select the desired channels.  
DX102P: 01 - 02  
DX104P: 01 - 04  
DX106P: 01 - 06  
DX112P: 01 - 12
2. Mode  
Select the input type or the computation type.  
[Volt]: DC voltage  
[TC]: Thermocouple  
[RTD]: Resistance temperature detector  
[DI]: Digital input  
[Delta]: Difference  
[Scale]: Scaling  
[Sqrt]: Square root  
[Skip]: Not used
3. Type  
Select the input type when [Delta] or [Scale] is selected for [Mode].  
[Volt]: DC voltage  
[TC]: Thermocouple  
[RTD]: Resistance temperature detector  
[DI]: Digital input
4. Range  
Select the input range corresponding to the selected [Mode] or [Type].
5. Span\_L, Span\_U  
Set the upper and lower limits of the display span.  
Pressing the [Input] soft key displays a window used to enter a numerical value.  
Enter a value in the allowed range and press the DISP/ENTER key.  
For the procedures related to entering numerical values, see section 3.6, "Entering Numbers and Characters."

### Note

---

- Span lower limit and span upper limit cannot be set to the same value.
  - For the difference computation ([Delta] is selected for [Mode]), refer to the following notes.
    - For TC or RTD input, the display span cannot exceed the difference between the maximum and the minimum of the input range.  
**Example:** For TC type L, the measurable range is  $-200.0$  to  $900.0$  °C.  
The range of display span is calculated as  $(-200.0 - (-900.0))$  to  $(900.0 - (-200.0))$ , namely,  $-1100.0$  to  $1100.0$  °C.
  - For DC voltage input, the display span cannot exceed the measurable range.
- 

6. Ref. CH  
Set the reference channel when [Delta] is selected for [Mode] (see "Explanation").
7. Scale\_L, Scale\_U  
Set the upper and lower limits of the scale.  
Enter a value in the allowed range using the same method as step 5.
  - Allowed range:  $-30000$  to  $30000$
  - Decimal position  
The decimal can be set in the following positions:  
"□.□□□□" "□□.□□□□" "□□□.□□□□" "□□□□.□□" "□□□□□□"
  - The decimal position is determined by the scale lower limit setting.

**Note**

- Scale lower limit and scale upper limit cannot be set to the same value.
- The DX100P converts the measured data within a value span derived by removing the decimal from the scaling upper and lower limits. In other words, conversion is performed by using a span of 10 if the scale setting is  $-5$  to  $5$ , and  $100$  if the scale setting is  $-5.0$  to  $5.0$ . The resolution of the value derived by using a span of  $10$  is coarser than the value derived using a span of  $100$ . Because the display becomes rough, set this value so that it is greater than  $100$ .

## 8. Unit

Set the unit when [Scale] or [Sqrt] is selected for [Mode].

Pressing the [Input] soft key displays a window used to enter a character string. Enter the unit (up to 6 alphanumeric characters) and press the DISP/ENTER key. For the procedures related to entering character strings, see section 3.6, "Entering Numbers and Characters."

**Confirming Operation**

To confirm the new settings, press the DISP/ENTER key.

To cancel the new settings, press the ESC key. A window appears for you to confirm the cancellation. Select [Yes] using the arrow keys and press the DISP/ENTER key.

**Explanation****Measurable Range**

The following table shows the range and measurable range for each input type.

Mode	Range	Measurable Range
Volt	20 mV	-20.00 to 20.00 mV
	60 mV	-60.00 to 60.00 mV
	200 mV	-200.0 to 200.0 mV
	2 V	-2.000 to 2.000 V
	6 V	-6.000 to 6.000 V
	20 V	-20.00 to 20.00 V
	50 V	-50.00 to 50.00 V

Mode	Range	Measurable Range (°C)	Measurable Range (°F)	Note
TC	R	0.0 to 1760.0°C	32 to 3200°F	IEC584, DIN IEC584, JIS C1602-1995
	S	0.0 to 1760.0°C	32 to 3200°F	IEC584, DIN IEC584, JIS C1602-1995
	B	0.0 to 1820.0°C	32 to 3308°F	IEC584, DIN IEC584, JIS C1602-1995
	K	-200.0 to 1370.0°C	-328 to 2498°F	IEC584, DIN IEC584, JIS C1602-1995
	E	-200.0 to 800.0°C	-328.0 to 1472.0°F	IEC584, DIN IEC584, JIS C1602-1995
	J	-200.0 to 1100.0°C	-328.0 to 2012.0°F	IEC584, DIN IEC584, JIS C1602-1995
	T	-200.0 to 400.0°C	-328.0 to 752.0°F	IEC584, DIN IEC584, JIS C1602-1995
	N	0.0 to 1300.0°C	32 to 2372°F	IEC584, DIN IEC584, JIS C1602-1995
	W	0.0 to 2315.0°C	32 to 4199°F	W-5% Re/W-26% Re (Hoskins Mfg.Co.), ASTM E988
	L	-200.0 to 900.0°C	-328.0 to 1652.0°F	Fe-CuNi, DIN 43710
U	-200.0 to 400.0°C	-328.0 to 752.0°F	Cu-CuNi, DIN 43710	
RTD	Pt100	-200.0 to 600.0°C	-328.0 to 1112.0°F	JIS C1604-1989, JIS C1606-1997, IEC751-1995, DIN IEC751-1996
	JPt100	-200.0 to 550.0°C	-328.0 to 1022.0°F	JIS C1604-1989, JIS C1606-1989
	CU1	-200.0 to 300.0°C	-328.0 to 572.0°F	CU10 Ω GE1 (Cuid based on a particular manufacturer)
	CU2	-200.0 to 300.0°C	-328.0 to 572.0°F	CU10 Ω L&N (Cuid based on a particular manufacturer)
	CU3	-200.0 to 300.0°C	-328.0 to 572.0°F	CU10 Ω WEED (Cuid based on a particular manufacturer)
	CU4	-200.0 to 300.0°C	-328.0 to 572.0°F	CU10 Ω BAILAY (Cuid based on a particular manufacturer)
	CU5	-200.0 to 300.0°C	-328.0 to 572.0°F	CU10 Ω $\alpha = 0.00392$ at 20°C
	CU6	-200.0 to 300.0°C	-328.0 to 572.0°F	CU10 Ω $\alpha = 0.00393$ at 20°C
	CU25	-200.0 to 300.0°C	-328.0 to 572.0°F	CU25 Ω $\alpha = 0.00425$ at 0°C

Cu1 to 6, and Cu25 are options.

## 5.1 Setting Measuring Range

Mode	Range	Measurable Range
DI	Level	0: Less than 2.4 V 1: Greater than or equal to 2.4 V
	Contact	0: Opened 1: Closed

### Measurable Range for Difference Computation

The following table shows the input type, range, and measurable range for difference computation.

Type	Range	Measurable Range	
Volt	20 mV	-20.00 to 20.00 mV	
	60 mV	-60.00 to 60.00 mV	
	200 mV	-200.0 to 200.0 mV	
	2 V	-2.000 to 2.000 V	
	6 V	-6.000 to 6.000 V	
	20 V	-20.00 to 20.00 V	
	50 V	-50.00 to 50.00 V	
TC	R	-1760.0 to 1760.0°C	-3168 to 3168°F
	S	-1760.0 to 1760.0°C	-3168 to 3168°F
	B	-1820.0 to 1820.0°C	-3276 to 3276°F
	K	-1570.0 to 1570.0°C	-2826 to 2826°F
	E	-1000.0 to 1000.0°C	-1800.0 to 1800.0°F
	J	-1300.0 to 1300.0°C	-2340.0 to 2340.0°F
	T	-600.0 to 600.0°C	-1080.0 to 1080.0°F
	N	-1300.0 to 1300.0°C	-2340 to 2340°F
	W	-2315.0 to 2315.0°C	-4167 to 4167°F
	L	-1100.0 to 1100.0°C	-1980.0 to 1980.0°F
	U	-600.0 to 600.0°C	-1080.0 to 1080.0°F
RTD	Pt100	-800.0 to 800.0°C	-1440.0 to 1440.0°F
	JPt100	-750.0 to 750.0°C	-1350.0 to 1350.0°F
	CU1 to 6 (CU10)	-500.0 to 500.0°C (option)	-900.0 to 900.0°F
	CU25	-500.0 to 500.0°C (option)	-900.0 to 900.0°F
DI	Level	-1 to 1	
	Contact	-1 to 1	

## 5.2 Setting Alarm

This section describes the procedure related to setting the alarm on measurement channels. For the procedure to set alarms on computation channels, see section 5.18.

### Note

- Set the measurement range before setting the alarm.
- All of the alarm settings of a channel are canceled in the following cases:
  - When the input type is changed (Volt, TC, etc.).
  - When the input range is changed.
  - When the upper and lower limits of the span or scale are changed on channels that are set to scaling or square root computation (including changes in the decimal point position).

### Procedure

Press .

To display the setting screen press the soft key .

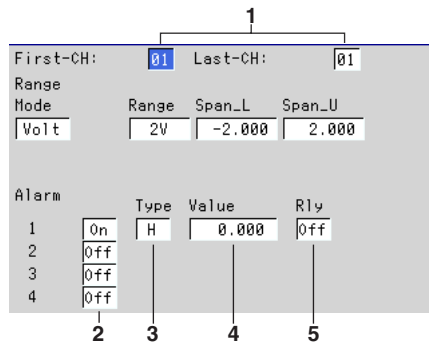

1. First-CH, Last-CH  
Select the desired channels (For the channels set here, [Range] is also simultaneously set).
2. On/Off  
When the alarm is turned on, [Type], [Value], and [Relay On/Off] are displayed.
3. Type  
Set the alarm type.  
[H]: Upper limit alarm  
[L]: Lower limit alarm  
[h]: Difference upper limit alarm  
[l]: Difference lower limit alarm  
[R]: Upper limit on rate-of-change alarm  
[r]: Lower limit on rate-of-change alarm  
[T]: Delay upper limit alarm  
[t]: Delay lower limit alarm

### **Note**

If you select delay alarm (T or t) for the alarm type, you must set the alarm delay period. See section 5.5.

---

4. Value  
Enter the value at which the alarm is activated.  
Pressing the [Input] soft key displays a window used to enter a numerical value.  
Enter a value in the allowed range and press the DISP/ENTER key.  
For the procedures related to entering numerical values, see section 3.6, "Entering Numbers and Characters."
- 5.\* Rly  
Set whether or not to activate the output relay (On/Off). When turned ON, the output relay number box appears.
- 6.\* No.  
Set the output relay number. For the correspondence between the output relay number and the output relay position, see section 2.5.

\* When the alarm output relay option is not installed, these settings are void.

### **Confirming Operation**

To confirm the new settings, press the DISP/ENTER key.

To cancel the new settings, press the ESC key. A window appears for you to confirm the cancellation. Select [Yes] using the arrow keys and press the DISP/ENTER key.

## 5.3 Setting Tag Names

Set tag names for the measurement and computation channels. The system mode is used to select whether tag names or channel numbers are displayed (see section 4.9).

### Procedure

Press .

#### Setting on a Measurement Channel

To display the setting screen press the soft key .

#### Setting on a Computation Channel (Option)

Twice press the soft key .

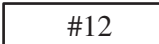
To display the setting screen press the soft key .

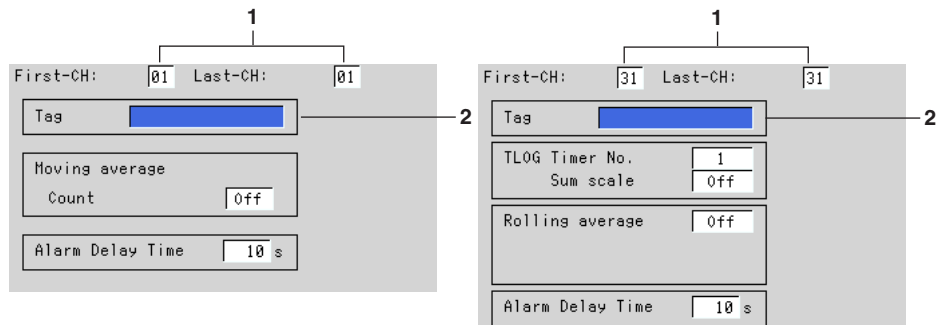

1. First-CH, Last-CH  
Select the desired channels (For the channels set here, other parameters shown in the above figure are also simultaneously set).
2. Tag  
Set a character string as a tag name.  
Pressing the [Input] soft key displays a window used to enter a string. Enter the tag name (up to 16 alphanumeric characters) and press the DISP/ENTER key.  
For the procedures related to entering character strings, see section 3.6, "Entering Numbers and Characters."

#### Confirming Operation

To confirm the new settings, press the DISP/ENTER key.

To cancel the new settings, press the ESC key. A window appears for you to confirm the cancellation. Select [Yes] using the arrow keys and press the DISP/ENTER key.

## 5.4 Setting Input Filter and Moving Average

Set the input filter (for DX102P/DX104P, low pass filters) or the moving average of the input (for DX106P/DX112P).

### Procedure

Press .

To display the setting screen press the soft key .

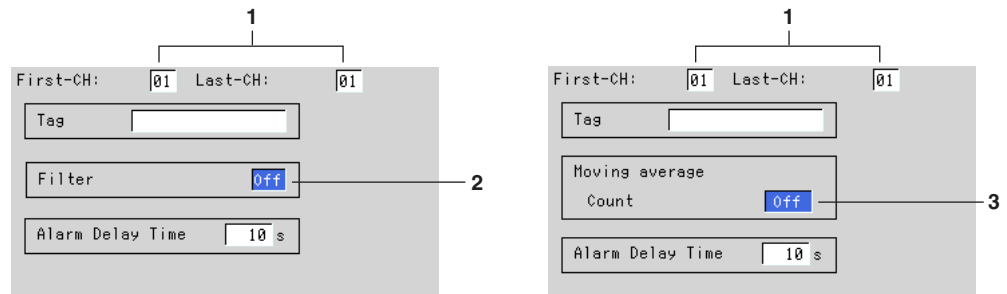

1. First channel and last channel  
Select the desired channels (For the channels set here, other parameters shown in the above figure are also simultaneously set).

### Input Filter Setting (for DX102P/DX104P)

2. Filter  
Select the time constant of the filter.  
[Off]: Do not use the filter  
[2s]: Filter time constant 2 s  
[5s]: Filter time constant 5 s  
[10s]: Filter time constant 10 s

### Moving Average Setting (for DX106P/DX112P)

3. Moving Average - Count  
Select the number of data points (2 to 16) for the moving average.  
[Off]: Do not use moving average

### Note

Regardless of this setting, filter and moving average operations are not performed for the digital inputs (DI).

### Confirming Operation

To confirm the new settings, press the DISP/ENTER key.

To cancel the new settings, press the ESC key. A window appears for you to confirm the cancellation. Select [Yes] using the arrow keys and press the DISP/ENTER key.



## 5.5 Setting the Alarm Delay Period

Set the alarm delay period for delay upper/lower limit alarm.

### Procedure

Press .

#### Setting on a Measurement Channel

To display the setting screen press the soft key .

#### Setting on a Computation Channel (Option)

Twice press the soft key .

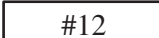
To display the setting screen press the soft key .

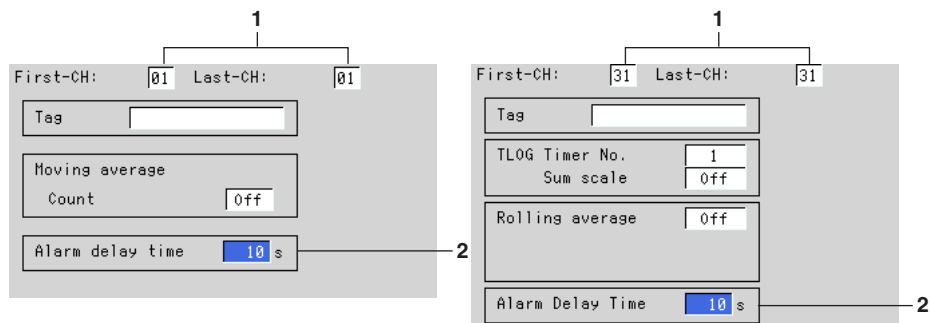

1. First-CH, Last-CH  
Select the desired channels (For the channels set here, other parameters shown in the above figure are also simultaneously set).
2. Alarm Delay Time  
Set the alarm delay period for the delay upper/lower limit alarm.  
Pressing the [Input] soft key or one of the character/number input keys displays a window used to enter the alarm delay period. Enter an integer value in the range 1 to 3600 s and press the DISP/ENTER key. For the procedures related to entering numerical values, see section 3.6, "Entering Numbers and Characters."  
If the scan interval is 2 s and you set an odd value for the alarm delay period, it will operate at the specified period + 1 s.  
**Example:** If the alarm delay period is set to 5 s, it will operate at 6 s.

#### Confirming Operation

To confirm the new settings, press the DISP/ENTER key.

To cancel the new settings, press the ESC key. A window appears for you to confirm the cancellation. Select [Yes] using the arrow keys and press the DISP/ENTER key.

## 5.6 Setting the Display Update Rate and Auto Save Interval

The time period corresponding to 1 division on the time axis on the trend display is specified. The sampling interval of the display data is also determined by the display update rate.

The auto save interval is the interval at which the display data residing in the internal memory are delimited and stored to the external storage medium. If the type of process is set to [Batch] (see section 4.3), it cannot be changed.

### Procedure

Press .

To display the setting screen press the soft key .

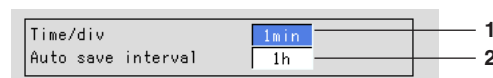

1. Time/div (Display update rate)  
Select the display update rate from 15 s\*, 30 s\*, 1 min, 2 min, 5 min, 10 min, 15 min, 20 min, 30 min, 1 h, 2 h, 4 h and 10 h.  
\* for DX102P and DX104P only
2. Auto save interval  
Select the auto save interval from the choices shown on the soft keys (see "Explanation").

### Note

- The selectable values for [Auto save interval] vary depending on the [Time/div] setting.
- If the type of process is set to [Batch] (see section 4.3), the [Auto save interval] is set to the maximum possible value and cannot be changed.

### Confirming Operation

To confirm the new settings, press the DISP/ENTER key.

To cancel the new settings, press the ESC key. A window appears for you to confirm the cancellation. Select [Yes] using the arrow keys and press the DISP/ENTER key.

### Explanation

#### The Display Data Sampling Interval and the Speed of Movement of Waveforms along the Time Axis

The following table shows the display update rate, display data sampling interval, and the speed of movement of waveforms along the time axis

Display Update Rate (/div)	15 s*	30 s*	1 min	2 min	5 min	10 min	15 min	20 min	30 min	1 h	2 h	4 h	10 h
Display data sampling interval (s)	0.5	1	2	4	10	20	30	40	60	120	240	480	1200
Speed of movement of waveforms (approximate value, mm/h)	2376	1188	594	297	119	59	40	30	20	10	5	2.5	1.0

\* for DX102P and DX104P only

## 5.6 Setting the Display Update Rate and Auto Save Interval

### Choices for the Auto Save Interval

The maximum auto save interval varies depending on the display update rate (sampling interval is determined from the display update rate) and the number of measurement and computation channels to be stored (see section 4.3). The available choices for the auto save interval from the table below are displayed on the soft key.

Display update rate (/DIV)	15 s*	30 s*	1 min	2 min	5 min	10 min	15 min	20 min	30 min	1 h	2 h	4 h	10 h
Sampling interval (s)	0.5	1	2	4	10	20	30	40	60	120	240	480	1200
Auto save interval (choices)	10 min	10 min	10 min	10 min	10 min	10 min	10 min						
	20 min	20 min	20 min	20 min	20 min	20 min	20 min						
	30 min	30 min	30 min	30 min	30 min	30 min	30 min						
	1 h	1 h	1 h	1 h	1 h	1 h	1 h	1 h	1 h	1 h			
	2 h	2 h	2 h	2 h	2 h	2 h	2 h	2 h	2 h	2 h	2 h		
	3 h	3 h	3 h	3 h	3 h	3 h	3 h	3 h	3 h	3 h	3 h		
	4 h	4 h	4 h	4 h	4 h	4 h	4 h	4 h	4 h	4 h	4 h	4 h	
	6 h	6 h	6 h	6 h	6 h	6 h	6 h	6 h	6 h	6 h	6 h	6 h	
	8 h	8 h	8 h	8 h	8 h	8 h	8 h	8 h	8 h	8 h	8 h	8 h	8 h
	12 h	12 h	12 h	12 h	12 h	12 h	12 h	12 h	12 h	12 h	12 h	12 h	12 h
	1 day	1 day	1 day	1 day	1 day	1 day	1 day	1 day	1 day	1 day	1 day	1 day	1 day
	2 day	2 day	2 day	2 day	2 day	2 day	2 day	2 day	2 day	2 day	2 day	2 day	2 day
		3 day	3 day	3 day	3 day	3 day	3 day	3 day	3 day	3 day	3 day	3 day	3 day
			5 day	5 day	5 day	5 day	5 day	5 day	5 day	5 day	5 day	5 day	5 day
			7 day	7 day	7 day	7 day	7 day	7 day	7 day	7 day	7 day	7 day	7 day
				10 day	10 day	10 day	10 day	10 day	10 day	10 day	10 day	10 day	10 day
				14 day	14 day	14 day	14 day	14 day	14 day	14 day	14 day	14 day	14 day
					31 day	31 day	31 day	31 day	31 day	31 day	31 day	31 day	31 day

\* for DX102P and DX104P only

## 5.7 Setting the File Header and Directory Name

### File Header

A header comment specified here is written to the display data file, event data file, manual sampled data file, TLOG data file (option) and report data file (option).

### Directory Name

When saving data to the external storage medium, you can specify the name of the directory to which the files are to be saved. The display data, event data, manual sampled data, TLOG data (option), report data (option), and screen image data are saved to this directory. The initial setting is "DATA0."

### Procedure

Press .

Press the soft key .

To display the setting screen press the soft key .

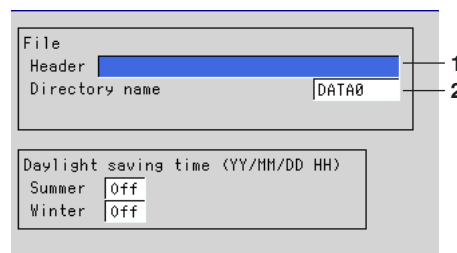

1. Header  
Set a header comment for data files.  
Pressing the [Input] soft key displays a window used to enter a string. Enter the header (up to 32 alphanumeric characters) and press the DISP/ENTER key.  
For the procedures related to entering character strings, see section 3.6, "Entering Numbers and Characters."
2. Directory name  
Set the name (up to 8 alphanumeric characters) of the directory to which the files are to be saved using the same method as step 1.

### Note

The following characters or strings cannot be used as file names.  
"AUX," "CON," "PRN," "NUL," "CLOCK," character strings that include a space or spaces

### Confirming Operation

To confirm the new settings, press the DISP/ENTER key.

To cancel the new settings, press the ESC key. A window appears for you to confirm the cancellation. Select [Yes] using the arrow keys and press the DISP/ENTER key.

## 5.8 Assigning an Action to the USER Key

An action can be assigned to the USER key.

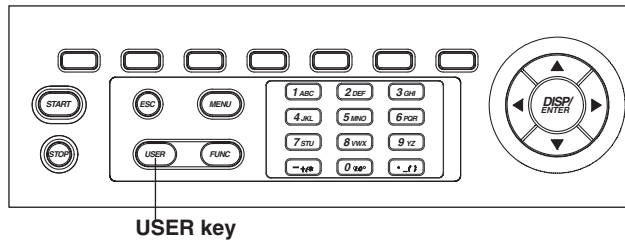

### Note

If logged in as a user that is not permitted to execute the assigned operation (see section 1.5), the operation cannot be executed using the USER key. Even if the operation is registered to the USER key, it is invalid.

### Procedure

Press .

To display the setting screen press the soft key .

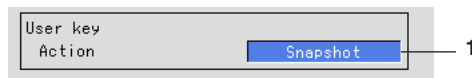

1. Action  
Select the action (see "Explanation") to be assigned.

### Confirming Operation

To confirm the new settings, press the DISP/ENTER key.

To cancel the new settings, press the ESC key. A window appears for you to confirm the cancellation. Select [Yes] using the arrow keys and press the DISP/ENTER key.

### Explanation

#### Actions That Can Be Assigned and the Reference Sections for Operation

For details of actions, see section 1.10.

Soft Key	Ref. section	Note
None	-	No operation
AlarmACK	8.12	
Math	8.4	When computation function (/M1) is equipped.
Math rst	8.4	When computation function (/M1) is equipped.
M.sample	8.3	
Message 1 to 8	8.2	Messages 1 to 8 of the message group 7 can be assigned.
Snapshot	8.5	

## 5.9 Setting Groups and Trip Lines

Trend, digital, and bar graph screens are displayed in groups. Channels can be assigned to each group and the group name can be registered.

- Number of groups: 6
- Number of channels: Up to 10 channels/group

A line to indicate a particular value of interest (trip line) can be displayed on the trend display.

- The maximum number of trip lines that can be displayed in one group is four.
- You can specify the thickness of the trip lines (see section 5.13).

### Procedure

Press .

Press the soft key .

Press the soft key .

To display the setting screen press the soft key .

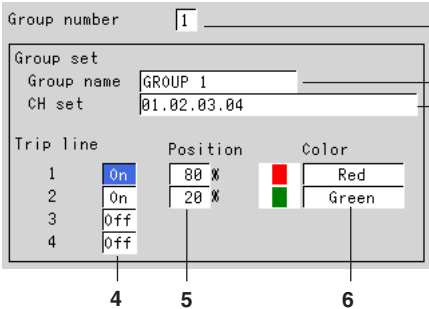

Trip line	Position	Color
1	80 %	Red
2	20 %	Green
3		
4		

1. Group number  
Select the group number (1 to 6).
2. Group name  
Set the name of the group.  
Pressing the [Input] soft key displays a window used to enter a string. Enter the group name (up to 16 alphanumeric characters) and press the DISP/ENTER key. For the procedures related to entering character strings, see section 3.6, "Entering Numbers and Characters."
3. CH set  
Assign measurement/computation channels to groups using the same method as step 2.
  - Enter the channel number using two digits.
  - Separate each channel with a period.
  - Consecutive channels can be specified using a hyphen.**Example:** To set CH1, CH3, CH5 to CH8 to a particular group, "01.03.05-08" is entered.

### Note

- The channels are displayed in the order they are specified on the trend, digital, bar graph screens.
- One channel can be assigned to multiple groups.
- A channel cannot be assigned twice in the same group.

4. On/Off  
 Move the cursor to the desired trip line and press the [On] soft key. The [Position] and [Color] boxes appear.  
 [On]: Use the trip line.  
 [Off]: Not use the trip line.
5. Position  
 Set the display position of the trip line.  
 Pressing the [Input] soft key displays a window used to enter a numerical value. Enter a value (1 to 100) and press the DISP/ENTER key. For the procedures related to entering numerical values, see section 3.6, "Entering Numbers and Characters."
6. Color  
 Select the color of the trip line from 16 colors (Red, green, blue, blue violet, brown, orange, yellow-green, light blue, violet, gray, limes, cyan, dark blue, yellow, silver, and purple).

**Confirming Operation**

To confirm the new settings, press the DISP/ENTER key.  
 To cancel the new settings, press the ESC key. A window appears for you to confirm the cancellation. Select [Yes] using the arrow keys and press the DISP/ENTER key.

**Explanation**

**Initial Settings of the Groups**

Group Name	
Group 1: GROUP 1	Group 4: GROUP 4
Group 2: GROUP 2	Group 5: GROUP 5
Group 3: GROUP 3	Group 6: GROUP 6

The initial setting varies depending on the models (the number of installed channels.)

Group Number	DX102P	DX104P	DX106P	DX112P
1	01.02	01.02.03.04	01.02.03.04.05.06	01.02.03.04.05.06
2	01.02	01.02.03.04	01.02.03.04.05.06	07.08.09.10.11.12
3	01.02	01.02.03.04	01.02.03.04.05.06	01.02.03.04.05.06
4	01.02	01.02.03.04	01.02.03.04.05.06	07.08.09.10.11.12
5	01.02	01.02.03.04	01.02.03.04.05.06	01.02.03.04.05.06
6	01.02	01.02.03.04	01.02.03.04.05.06	07.08.09.10.11.12

**Initial Colors of the Trip Lines**

- Trip line No.1: Red
- Trip line No.2: Green
- Trip line No.3: Blue
- Trip line No.4: Yellow

## 5.10 Setting the Channel Display Colors (Trend, Bar Graph)

### Procedure

Press .

Press the soft key .

Press the soft key .

#### Setting on a Measurement Channel

To display the setting screen press the soft key .

#### Setting on a Computation Channel (Option)

To display the setting screen press the soft key .

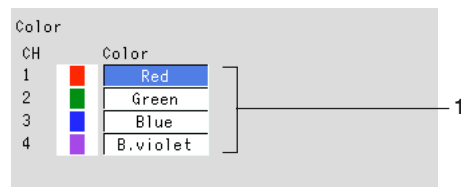

#### 1. Color

Move the cursor to the desired channel and select the channel display color from 16 colors (Red, green, blue, blue violet, brown, orange, yellow-green, light blue, violet, gray, limes, cyan, dark blue, yellow, silver, and purple).

#### Confirming Operation

To confirm the new settings, press the DISP/ENTER key.

To cancel the new settings, press the ESC key. A window appears for you to confirm the cancellation. Select [Yes] using the arrow keys and press the DISP/ENTER key.

### Explanation

#### Initial Settings of Channel Display Color

Channel 1: Red, Channel 2: Green, Channel 3: Blue, Channel 4: Blue violet, Channel 5: Brown, Channel 6: Orange, Channel 7: Yellow-green, Channel 8: Light blue, Channel 9: violet, Channel 10: Gray, Channel 11: Red, Channel 12: Green, Channel 13: Blue, Channel 14: Blue violet, Channel 15: Brown, Channel 16: Orange, Channel 17: Yellow-green, Channel 18: Light blue, Channel 19: violet, Channel 20: Gray, Channel 21: Red, Channel 22: Green, Channel 23: Blue, Channel 24: Blue violet, Channel 25: Brown, Channel 26: Orange, Channel 27: Yellow-green, Channel 28: Light blue, Channel 29: violet, Channel 30: Gray



## 5.11 Setting Zone Displays/Partial Expanded Displays (Trend)

For details on the zone display function and the partial expanded display function, see section 1.3.

To use the partial expanded display, first set the partial expanded display to [Use] in the system mode (see section 4.9). If not, a partial expanded display setting box in the engineering mode will not be displayed.

### Procedure

Press .

Press the soft key .

Press the soft key .

#### Setting on a Measurement Channel

To display the setting screen press the soft key .

#### Setting on a Computation Channel (Option)

To display the setting screen press the soft key .

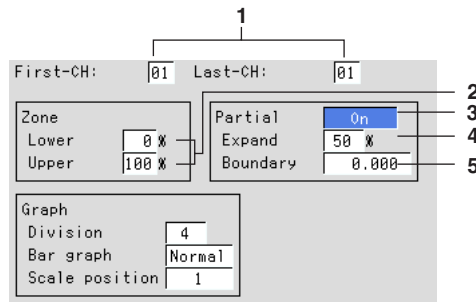

1. First-CH, Last-CH

Select the desired channels (For the channels set here, other parameters shown in the above figure are also simultaneously set).

#### Zone Displays

2. Zone Lower/Upper

Set the waveform display zone (from [Lower] to [Upper]).

[Lower]: 0 to 95%

[Upper]: 5 to 100%

Pressing the [Input] soft key displays a window used to enter a numerical value.

Enter a value and press the DISP/ENTER key.

For the procedures related to entering numerical values, see section 3.6, "Entering Numbers and Characters."

#### Note

- [Lower] must be a smaller value than [Upper].
- The width of the zone (upper limit – lower limit) must be greater than or equal to 5%.

### Partial Expanded Display

3. Partial  
When [On] is selected, the [Expand] and [Boundary] boxes are displayed.  
[On]: Use the partial expanded display.  
[Off]: Not use the partial expanded display.
4. Expand  
Set the position to which a particular value (the boundary, see step 4) in the display span is to be moved as a percentage of the display span.  
Pressing the [Input] soft key displays a window used to enter a numerical value. Enter the position and press the DISP/ENTER key. For the procedures related to entering numerical values, see section 3.6, "Entering Numbers and Characters."  
The range for the position: 1 to 99
5. Boundary  
Set the boundary value within the display span. By moving the value within the display span to another position (see step 4), the area on either side of the boundary is expanded or compressed.  
Enter the boundary using the same method as step 4.  
The range for the boundary:  
    The minimum value of the span +1 digit to the maximum value of the span -1 digit (when the range is not set to "scaling")  
    The minimum value of the scale +1 digit to the maximum value of the scale -1 digit (when the range is set to "scaling").

### Confirming Operation

To confirm the new settings, press the DISP/ENTER key.

To cancel the new settings, press the ESC key. A window appears for you to confirm the cancellation. Select [Yes] using the arrow keys and press the DISP/ENTER key.

### Note

---

- The partial expanded display is turned [Off] for all channels if the partial expanded display setting (use/not use) in the system mode is changed and stored.
  - When the range setting of the channel is set to [Skip] or when the span width is less than or equal to 1 digit, the partial expanded display cannot be specified. (The box is grayed in this case.)
-

## 5.12 Setting the Scale Division, Bar Graph Base Position (Bar Graph), and Scale Position (Trend)

- The scale used on trend and bar graphs can be set.
- When the bar graph is displayed horizontally, the base position of the bar graph can be set on each channel by selecting either [Normal] or [Center].  
[Normal]: The left edge or the right edge of the display span depending on which value is smaller.  
[Center]: Position at 50% of the display span
- For the procedures to set the vertical or horizontal display, see section 5.13.
- The scale display position for each channel can be specified on the trend screen.

### Procedure

Press .

Press the soft key .

Press the soft key .

Setting on a measurement channel

To display the setting screen press the soft key .

Setting on a computation channel (option)

To display the setting screen press the soft key .

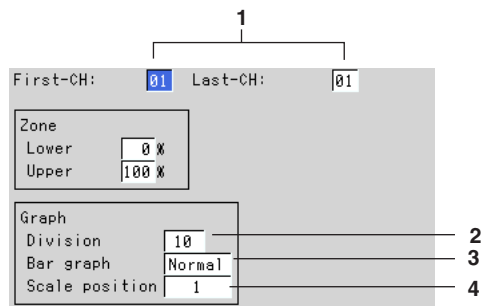

### 1. First-CH, Last-CH

Select the desired channels (For the channels set here, other parameters shown in the above figure are also simultaneously set).

### Setting the Number of Divisions for the Scale

#### 2. Division

Select the number of scale divisions from [4] to [12] and [C10]. The scale is equally divided and scale marks are displayed at the divided position.

[C10]: The scale is equally divided into 10 divisions by main scale marks, and scale values are indicated at 0, 30, 50, 70, and 100% positions.

On the bar graph screen: Only the main scale marks are displayed.

On the trend screen: See "Explanation."

## 5.12 Setting the Scale Division, Bar Graph Base Position (Bar Graph), and Scale Position (Trend)

---

### Setting the Bar Graph's Base Position

3. Bar graph (base position of the bar graph)  
Select the base position of the bar graph from [normal] and [center] (see "Explanation").

### **Note**

---

When the bar graph is displayed vertically (see section 5.13), the base position is fixed to [Normal] (the bottom of the bar graph is the base position).

---

### Setting the Scale Position on the Trend Screen

4. Scale position  
Select the scale display position when the scale is displayed on the trend screen (see section 7.2) from [1] to [6]. Select [Off] for channels without scale.

### **Note**

---

- The scale for the channels that are assigned to the group in the trend screen are displayed.
  - The larger the number of scales to be displayed, less amount of area there is to display the waveform.
- 

### Confirming Operation

To confirm the new settings, press the DISP/ENTER key.

To cancel the new settings, press the ESC key. A window appears for you to confirm the cancellation. Select [Yes] using the arrow keys and press the DISP/ENTER key.

**Explanation**

**Scale Display on the Trend Screen**

**Scale display position**

On the trend screen, the scale for the channels that are assigned to groups can be displayed in 6 different positions (see the figure below).

- **During trend vertical display (see page 7-19 for horizontal display)**

The scale display position is 1, 2, 3, 4, 5, and 6 from the top.

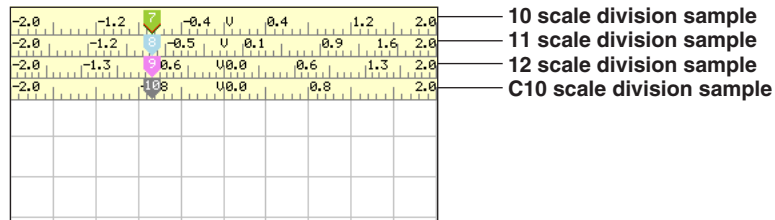
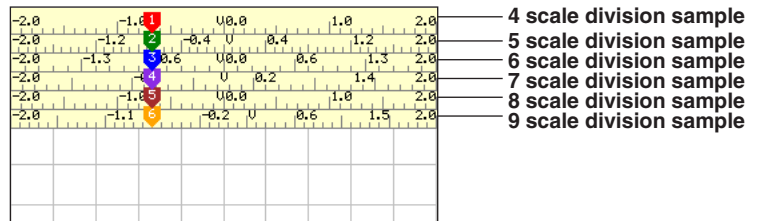

The scale is divided into 4 to 12 sections as shown in the figure above.

- [C10] Scale Division  
The scale is divided into 10 divisions and the scale values are displayed at 0, 30, 50, and 70 % positions of the scale (If [10] scale division is set, the scale values are at 0, 20, 40, 60, 80, and 100 % positions ).
- If the scales for two or more channels are specified to the same position, the scale for the channel that was assigned first to the group is displayed.

Example 1: When the channels were assigned to a group in the following order:

[03.02.01.05], and the scale display positions for channels 3, 2, 1, and 5 are all set to [1]

The scale for channel 3 is displayed at position 1.

- Vacant positions in between scale assigned positions are void. The scales are displayed close together from the display position 1.

Example 2: When the channels were assigned to a group in the following order:

[01.02.03.05], and the scale display position for channels 1, 2, 3, and 5 are set to positions 1, 3, 5, and 6, respectively

The scales for the channels are actually displayed at positions 1, 2, 3, and 4, respectively.

- If the scale display position is set to [Off], the scale is not displayed.

## 5.12 Setting the Scale Division, Bar Graph Base Position (Bar Graph), and Scale Position (Trend)

- **During trend horizontal display**

The scale display position is 6, 5, 4, 3, 2, and 1 from the left.

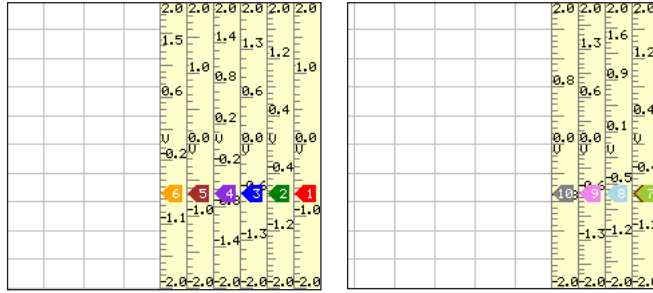

### Note

- **Scale marks**

The scale can be divided into 4 to 12 sections using the main scale marks. When the scale is divided into 4 or 5 section, the area between the main scale marks is divided further into 10 sections using small and medium marks. When the scale is divided into 6 to 12 sections, the area between the main scale marks is divided further into 5 sections using small marks.

However, small marks are not displayed for the following cases:

- When the measurement/computation range resolution is smaller than the total number of sections created by small marks.
- When zone display is used
- When partial expanded display is used

- **Scale values**

The scale values are displayed at all main scale marks when the scale is divided into 4 to 7 (4 to 6 for trend vertical display) sections using the main scale marks. When the scale is divided into 8 to 12 (7 to 12 for trend vertical display) sections, the scale values are displayed at every other main scale mark.

In addition, the upper or lower limit of the scale is displayed at the end of the scale.

Rule 1 Up to 3 digits excluding the minus sign can be displayed for the scale values.

Rule 2 If the integer section of either value at the end of the scale is less than or equal to one digit, the value is displayed as  $\square.\square$  or  $0.\square$ .

**Example 1:** If the scale is set to  $-0.05$  to  $0.5$ , the scale display for the upper and lower limits is  $-0.0$  to  $0.5$ .

**Example 2:** If the scale is set to  $-0.005$  to  $0.05$ , the scale display for the upper and lower limits are  $-0.0$  to  $0.0$ .

Rule 3 If the integer section of either value at the end of the scale is two digits or three digits, the value is displayed with the decimal fraction is discarded.

**Example 3:** If the scale is set to  $0.1$  to  $100.0$ , the scale display for the upper and lower limits is  $0$  to  $100$ .

Rule 4 If the integer section of either value at the end of the scale is greater than or equal to four digits, a three-digit mantissa and exponent are displayed ( $\times 10$  or  $\times 10^2$ , for example).

**Example 4:** If the scale is set to  $10$  to  $2000$ , the scale display for the upper and lower limits are  $0$  to  $200 \times 10$ .

## 5.12 Setting the Scale Division, Bar Graph Base Position (Bar Graph), and Scale Position (Trend)

The number of digits of the scale values can be increased by one digit within Rule 1. For the procedure, see section 5.13.

Consider the case when the scale marks are between 49.0 and 51.0 using [C10] division.

Normally the decimals of the scale values are truncated according to Rule 3. However, if the number of digits is increased by one, the values are displayed as follows:

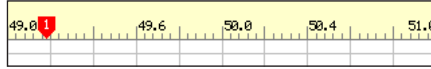

- **Unit**

The unit is displayed near the center of the scale. When the partial expanded display is used, the position will be shifted.

When the trend is displayed horizontally, the number of characters that can be displayed is up to 3. If the [Scale digit] is set to [Fine], up to 4 characters can be displayed.

### Bar Base Position on the Bar Graph Display

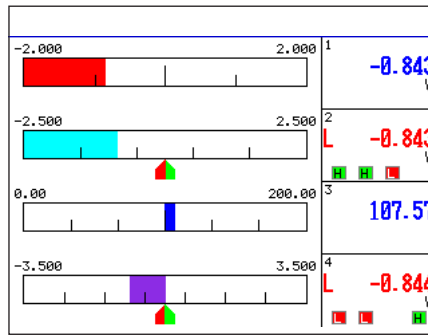

**Bar base position: normal**  
The bar base position is either the left end or right end whichever has a smaller scale value.

**Bar base position: center**  
The base position is at the center (50%) of the display span.

## 5.13 Setting the Display Direction, Background Color, Waveform Line Width, Trip Line Width, Grid, Scroll Time, and Scale digit

- The display direction of the trend and bar graph can be set to horizontal or vertical.
- The background color used in the trend, digital, bar graph, and information screens can be set to white or black (common to all screens).
- The line width of the waveform can be selected as 1, 2, or 3 dots.
- The line width of the trip line can be selected as 1, 2, or 3 dots.
- The grid lines can be displayed on the trend's waveform display area by dividing the display span into 4 to 12 sections.
- The interval at which the displayed group is automatically switched on the trend, digital, and bar graph screens can be specified. The displayed group rotates from group 1 to group 6.
- You can increase the number of digits of the scale values by one digit on the trend display.

### Procedure

Press .

Press the soft key .

Press the soft key .

To display the setting screen press the soft key .

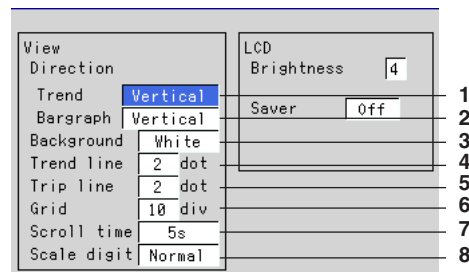

#### Set the Display Direction of the Trend

1. Direction - Trend  
Select the display direction of the trend from [Horizontal], [Vertical], and [Horizon2].

#### Set the Display Direction of the Bar Graph

2. Direction - Bar graph  
Select the display direction of the bar graph from [Vertical] and [Horizontal].

#### Set the Background Color

3. Background  
Select the background color from [White] and [Black].

#### Note

The background color of the historical trend is opposite that of the trend screen.



**Setting the Trend Line Width**

4. Trend line  
Select the width of the trend line as [1], [2], and [3] dots.

**Setting the Width of the Trip Line**

5. Trip line  
Select the width of the trip line as [1], [2], or [3] dots.

**Setting the Number of Grids on the Waveform Display Area**

6. Grid  
Select the number of grids from [4] to [12], and [Auto].  
[Auto]: Display the same number of grids as the number of scale divisions of the first assigned channel of the group.

**Setting the Interval at Which the Displayed Group is Automatically Switched**

7. Scroll time  
Select the interval from [5 s], [10 s], [20 s], [30 s], and [1 min].

**Setting the Number of Displayed Digits of the Scale Value**

8. Scale digit  
[Normal]: See the explanation given in “Scale values” in section 5.12.  
[Fine]: The number of displayed digits of the scale value is increased by one. See the explanation given in “Scale values” in section 5.12.

**Confirming Operation**

To confirm the new settings, press the DISP/ENTER key.  
To cancel the new settings, press the ESC key. A window appears for you to confirm the cancellation. Select [Yes] using the arrow keys and press the DISP/ENTER key.

**Explanation**

**Grid on the Waveform Display Area**

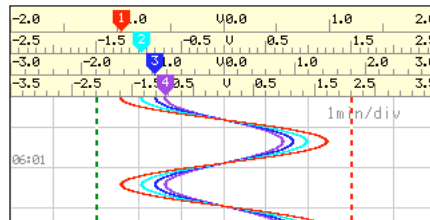

Grid(The number of grid is 10 in this example)

## 5.14 Setting the Brightness of the Screen and the Backlight Saver Function

- There are four screen brightness settings which can be selected (1 to 8).
- The lifetime of the LCD backlight can be extended by automatically dimming the light when there has been no key operation for a certain amount of time. The screen will return to the original brightness with a key operation or an alarm occurrence. The screen saver is initially disabled.

### Procedure

Press .

Press the soft key .

Press the soft key .

To display the setting screen press the soft key .

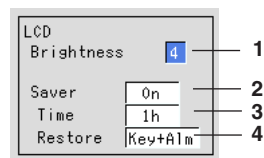

### Setting the Brightness of the Screen

1. Brightness  
Select the brightness of the screen from [1] to [8]. The initial setting is [4]. A higher number corresponds to a brighter screen setting.

### Setting the Backlight Saver

2. Saver  
Select [On] (use the backlight saver) or [Off] (not use the backlight saver).  
When [On] is selected, [Saver time] and [Restore] boxes are displayed.
3. Time  
Select the time from [1 min], [2 min], [5 min], [10 min], [30 min], and [1 hour].  
If the specified time elapses without any key operation, the LCD backlight is automatically dimmed.
4. Restore  
Select the trigger action to restore the original brightness of the screen from [Key] and [Key + Alm] (Key + Alarm).  
[Key]: The screen will return to the original brightness with a key operation.  
[Key + Alm]: The screen will return to the original brightness with a key operation or an alarm occurrence.

### Confirming Operation

To confirm the new settings, press the DISP/ENTER key.

To cancel the new settings, press the ESC key. A window appears for you to confirm the cancellation. Select [Yes] using the arrow keys and press the DISP/ENTER key.

## 5.15 Setting the Date and Time

Set the date and time on the internal clock of the DX100P.

### Note

When using the login function, only the administrator can set the date/time.

### Procedure

Press .

When data acquisition is stopped

Press the soft key .

To display the window for the date and time setting, press the soft key .

When data acquisition is in progress

Press the [Time] soft key. A window used to set the time appears.

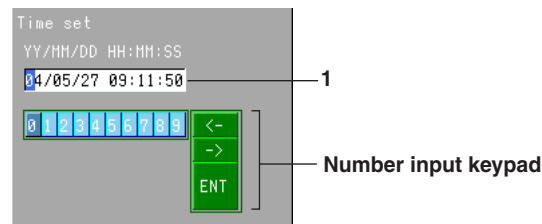

Pressing the [Input] soft key displays a cursor on the text box. Enter the date and time. For the procedures related to entering numbers, see section 3.6, “Entering Numbers and Characters.”

### Applying New Date and Time

Press the DISP/ENTER key to apply the settings and close the window.

To cancel the settings and close the window, press the ESC key.

### Explanation

#### Selectable Range of Date/Time

You can set the date/time in the range of 0 hour 0 minute 0 second of January 1, 1980 to 14 hour 0 minute 0 second of January 18, 2038.

#### Time Correction Operation

The time correction operation varies depending on whether data acquisition is in progress. For a description of the operation, see section 1.10.

The operation of changing the time during data acquisition must be set so that such operation is allowed in advance. For the setup procedure, see section 4.14.

## 5.16 Setting the Message String

### Procedure

Press .

To display the setting screen press the soft key .

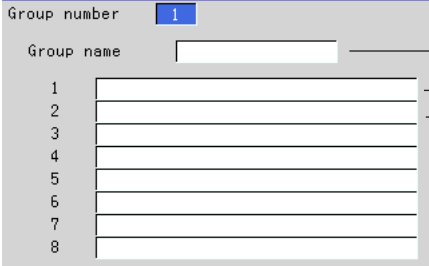

The screenshot shows a menu titled "Group number" with the value "1" selected. Below it is a "Group name" field with an empty input box. Underneath is a list of 8 message groups, numbered 1 through 8. Callout 1 points to the "Group number" field, callout 2 points to the "Group name" input field, and callout 3 points to the list of message groups.

1. Group number  
Select the message group number (1 to 7).
2. Group name  
Set the group name for the selected message group.  
Pressing the [Input] soft key displays a window used to enter a string. Enter the group name (up to 16 characters), and press the DISP/ENTER key. For the procedures related to entering strings, see section 3.6, "Entering Values and Strings."
3. 1 to 8  
Set the message strings (up to 8 strings) that belong to the selected message group.  
Move the cursor to the box corresponding to the message No. you wish to set. Pressing the [Input] soft key displays a window used to enter a string. Enter the message string (up to 32 characters) using the same method as step 2, and press DISP/ENTER.

### Confirming Operation

To confirm the new settings, press the DISP/ENTER key.

To cancel the new settings, press the ESC key. A window appears for you to confirm the cancellation. Select [Yes] using the arrow keys and press the DISP/ENTER key.

## 5.17 Setting the Batch Information

The following items can be specified.

- Whether to use lot numbers
- Whether to use the function to increase the lot number by one at Memory Stop
- Headers 1 to 3

### Procedure

Press .

Twice press the soft key .

To display the setting screen press the soft key .

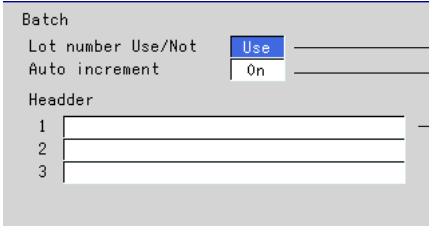

1. Lot number Use/Not  
If you enter [Use], the “Auto increment” box appears.  
[Use]: Use lot numbers  
[Not]: Not use lot numbers
2. Auto increment (of lot numbers)  
Set whether to automatically increase the lot number at Memory Stop as the lot number of the next batch.  
[On]: Automatically increase the lot number by “1.”  
[Off]: Do not change the lot number.

### Note

The lot number after “99999999” is “0.”

3. Headers 1, 2, 3  
Set the header comment for the display data file and the event data file.  
Pressing the [Input] soft key displays a window used to enter the string. Enter the header string (up to 64 characters), and press DISP/ENTER. For the procedures related to entering strings, see section 3.6, “Entering Values and Strings.”

### Confirming Operation

To confirm the new settings, press the DISP/ENTER key.

To cancel the new settings, press the ESC key. A window appears for you to confirm the cancellation. Select [Yes] using the arrow keys and press the DISP/ENTER key.

## 5.18 Setting Equations, Alarms, and Constants for Computation Channels (/M1 Option)

### Procedure

Press .

Twice press the soft key .

To display the setting screen press the soft key .

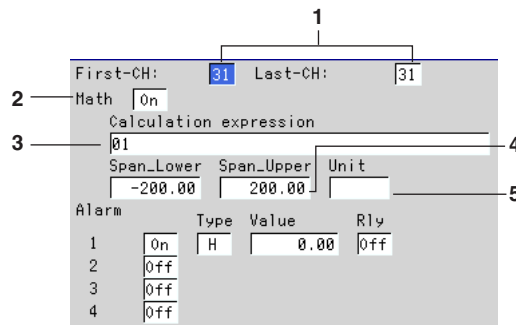

### Turning On/Off the Computation, Setting Equations

#### Note

When computation is turned On/Off or when equations and span settings are changed, the alarm setting for that channel is turned Off.

1. First-CH, Last-CH  
Select the desired channels.
2. Math  
Turn [On] or [Off] the computation of the selected channel. If [On] is selected a box for the equation will appear.  
[On]: Use the computation channel  
[Off]: Do not use the computation channel
3. Calculation expression  
Set the equation for the selected channel.  
Pressing the [Input] soft key displays a window used to enter an equation. Enter the equation (up to 40 characters) and press the DISP/ENTER key.

## 5.18 Setting Equations, Alarms, and Constants for Computation Channels (/M1 Option)

Use the following keys.

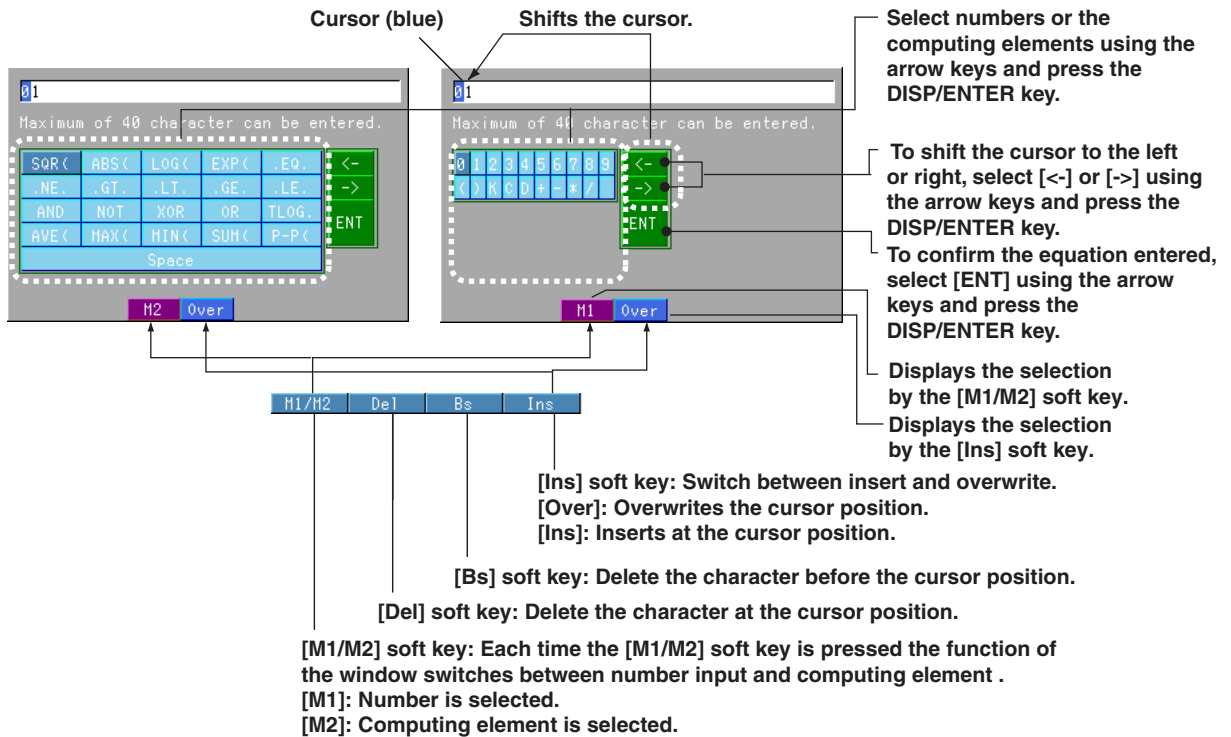

### Note

When using TLOG computation, timers must be set in the system mode and the number of the timer and the sum unit (only for TLOG.SUM) must be set in the engineering mode.

- Span\_Lower, Span\_Upper  
 Set the upper and lower limits of the display span.  
 Pressing the [Input] soft key displays a window used to enter a numerical value.  
 Enter a value in the allowed range given below and press the DISP/ENTER key.  
 For the procedures related to entering numerical values, see section 3.6, "Entering Numbers and Characters."  
 Allowed range: -9999999 to 99999999  
 The decimal can be set in the following positions:  
 "□.□□□□" "□□.□□□□" "□□□.□□□□" "□□□□.□□□□" "□□□□□□"

### Note

The upper and lower limits of span cannot be set to the same value.

- Unit  
 Set the unit for the computed value.  
 Pressing the [Input] soft key displays a window used to enter a character string.  
 Enter the unit (up to 6 alphanumeric characters) and press the DISP/ENTER key. For the procedures related to entering character strings, see section 3.6, "Entering Numbers and Characters."

### Confirming Operation

To confirm the new settings, press the DISP/ENTER key.

To cancel the new settings, press the ESC key. A window appears for you to confirm the cancellation. Select [Yes] using the arrow keys and press the DISP/ENTER key.

### Setting Alarms on Computation Channels

You can set up to 4 alarms on each computation channel. The hysteresis is not applied to alarms for computation channels.

**Note**

When [Math On/Off] is turned ON, an entry box used to enter the equation is displayed and the alarm setting boxes are activated (white color). Set the alarm after setting the equation. When computation is turned On/Off or when equations and span settings are changed, the alarm setting for that channel is turned OFF.

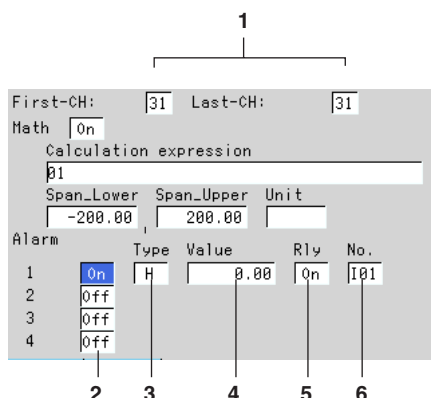

1. First-CH, Last-CH  
Select the desired channels (For the channels set here, the [Math range] is also simultaneously set).
2. On/Off  
Select [On] or [Off]. If [On] is selected, items 3, 4 and 5 are displayed.  
[On]: Use alarm  
[Off]: Do not use alarm
3. Type  
Set the alarm type (see section 1.6).  
[H]: Upper limit alarm  
[L]: Lower limit alarm  
[T]: Delay upper limit alarm  
[t]: Delay lower limit alarm

**Note**

If you select delay alarm (T or t) for the alarm type, you must set the alarm delay period. See section 5.5.

4. Value  
Set the value at which the alarm is activated.  
Pressing the [Input] soft key displays a window used to enter a numerical value. Enter a value and press the DISP/ENTER key. For the procedures related to entering numerical values, see section 3.6, "Entering Numbers and Characters."
- 5.\* Rly  
Select whether to use the relay output (On) or not to use the relay output (Off). If [On] is selected, output relay [Number] is displayed.

\* If the alarm output relay option (/AR1, /AR2, or /A3) is not installed, this setting is void.



- 6.\* No.  
 Set the output relay number.  
 For the correspondence between the output relay number and the output relay position, see section 2.5.

\* If the alarm output relay option (/AR1, /AR2, or /A3) is not installed, this setting is void.

**Confirming Operation**

To confirm the new settings, press the DISP/ENTER key.  
 To cancel the new settings, press the ESC key. A window appears for you to confirm the cancellation. Select [Yes] using the arrow keys and press the DISP/ENTER key.

**Setting Constants Used in Computation Equations**

Constants are used in computation equations. Up to 12 constants (K01 to K12) can be defined.

Press .

Twice press the soft key .

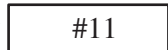
To display the setting screen press the soft key .

1

Constant			
K01:	1	K07:	1
K02:	1	K08:	1
K03:	1	K09:	1
K04:	1	K10:	1
K05:	1	K11:	1
K06:	1	K12:	1

1. Constant  
 Select the constant you wish to set using the arrow keys.  
 Pressing the [Input] soft key displays a window used to enter a numerical value.  
 Enter a value in the allowed range and press the DISP/ENTER key. For the procedures related to entering numerical values, see section 3.6, "Entering Numbers and Characters."

**Range of Numerical Values**

The number of significant digits is 5 excluding the decimal. When using exponents to set values, use 5 or less digits for the mantissa and two digits for the exponent.

The allowed range is as follows.

-9.9999E + 29 to -1.0000E - 30, 0, 1.0000E - 30 to 9.9999E + 29

**Confirming Operation**

To confirm the new settings, press the DISP/ENTER key.  
 To cancel the new settings, press the ESC key. A window appears for you to confirm the cancellation. Select [Yes] using the arrow keys and press the DISP/ENTER key.

### Explanation

This section describes the meaning of the computation equation and how to write them.

### Four Arithmetical Computations

The types of data that can be used in equations are measured data, computed data, constants (K01 to K12), communication interface data (C01 to C12), and the remote control terminal conditions (D01 to D08).

#### Example:

Addition (+): 01+02

Computes the measured value of channel 1 plus the measured value of channel 2

Subtraction (-): 01-02

Computes the measured value of channel 1 minus the measured value of channel 2

Multiplication (\*): 01\*K03

Computes the measured value of channel 1 multiplied by constant K03

Division (/): 01/K02

Computes the measured value of channel 1 divided by constant K02

#### Note

---

When you set an expression as e.g. 31 + 01 on channel 31, the summation of channel number 1 will be displayed in channel 31.

---

### Power, SQR, ABS, LOG, EXP Computations

The types of data that can be used in equations are measured data, computed data, constants (K01 to K12), communication interface data (C01 to C12), and the remote control terminal conditions (D01 to D08). You can nest a computing element inside the parentheses of another computing element.

#### Example:

Power (\*\*): 01\*\*02

Raises measured value of channel 1 to the power of measured value of channel 2

Square root (SQR): SQR (01)

Returns the square root of the measured value of channel 1

Absolute value (ABS): ABS (01)

Returns the absolute value of the measured value of channel 1

Logarithm (LOG): LOG (01)

Returns the common logarithm of the measured value of channel 1

Exponent (EXP): EXP (01)

Raises e to the power of the measured value of channel 1

#### Note

---

The natural logarithm is not directly provided, but can be obtained by using the following:

$\log_e x = \log_{10} x / \log_{10} e$  as  $\log_b x = \log_a x / \log_a b$

Therefore, to calculate the natural logarithm of the value of channel 01, set K01 = 1.

Then the expression will become: LOG (01)/LOG (EXP(K01))

---

## Relational Computation

The types of data that can be used in equations are measured data, computed data, constants (K01 to K12), communication interface data (C01 to C12), and the remote control terminal conditions (D01 to D08). You can specify a computing equation that performs relational computation on a computing element (Example: 01.LT.ABS(02)).

### Example:

#### 02.LT.03

The computed result will be "1" if the measured value of channel 2 is less than the measured value in channel 3, otherwise the value will be "0."

#### 02.GT.03

The computed result will be "1" if the measured value of channel 2 is greater than the measured value in channel 3, otherwise the value will be "0."

#### 02.EQ.03

The computed result will be "1" if the measured value of channel 2 is equal to the measured value in channel 3, otherwise the value will be "0."

#### 02.NE.03

The computed result will be "1" if the measured value of channel 2 is not equal to the measured value in channel 3, otherwise the value will be "0."

#### 02.GE.03

The computed result will be "1" if the measured value of channel 2 is greater than or equal to the measured value in channel 3, otherwise the value will be "0."

#### 02.LE.03

The computed result will be "1" if the measured value of channel 2 is less than or equal to the measured value in channel 3, otherwise the value will be "0."

## Logical Computation

The computation is performed using e1 and e2 which are identified as either "zero" or "non zero". The types of data that can be used in equations are measured data, computed data, constants (K01 to K12), communication interface data (C01 to C12), and the remote control terminal conditions (D01 to D08). You can specify a computing equation that performs logical computation on a computing element.

### AND Logical Product

Syntax: e1ANDe2

Condition: If both e1 and e2 are "non 0", the operation results in "1", otherwise in "0."

Status: e1 = 0, e2 = 0  
e1ANDe2 = 0

e1 ≠ 0, e2 = 0  
e1ANDe2 = 0

e1 = 0, e2 ≠ 0  
e1ANDe2 = 0

e1 ≠ 0, e2 ≠ 0  
e1ANDe2 = 1

**OR Logical Sum**

Syntax:  $e1ORe2$

Condition: If both  $e1$  and  $e2$  are "0", the operation results in "0", otherwise in "1."

Status:  $e1 = 0, e2 = 0$   
 $e1ORe2 = 0$

$e1 \neq 0, e2 = 0$   
 $e1ORe2 = 1$

$e1 = 0, e2 \neq 0$   
 $e1ORe2 = 1$

$e1 \neq 0, e2 \neq 0$   
 $e1ORe2 = 1$

**XOR Mutually Exclusive Logical Sum**

Syntax:  $e1XORe2$

Condition: If  $e1$  and  $e2$  have different values, the operation results in "1", otherwise in "0."

Status:  $e1 = 0, e2 = 0$   
 $e1XORe2 = 0$

$e1 \neq 0, e2 = 0$   
 $e1XORe2 = 1$

$e1 = 0, e2 \neq 0$   
 $e1XORe2 = 1$

$e1 \neq 0, e2 \neq 0$   
 $e1XORe2 = 0$

**NOT Logical Negation**

Syntax:  $NOTe1$

Condition: Reverses the value of data  $e1$

Status:  $e1 = 0$   $NOTe1 = 1$   
 $e1 \neq 0$   $NOTe1 = 0$

**Example:**

**01-02OR03.GT.04**

Determines the OR of the computed results of "01-02" and "03.GT.04."

**TLOG Computation (MAX, MIN, AVE, SUM, MAX-MIN)**

Only measured data and computed data can be used in the TLOG computation. In the explanation below, e1 is used to represent a measurement or computation channel. You cannot specify an equation that contains a computing element inside e1. In addition, only one TLOG computation can be specified in a single computing equation.

**TLOG.MAX ( )**

Syntax: TLOG.MAX (e1)

Result: Computes the maximum value of channel e1

**TLOG.MIN ( )**

Syntax: TLOG.MIN (e1)

Result: Computes the minimum value of channel e1

**TLOG.AVE ( )**

Syntax: TLOG.AVE (e1)

Result: Computes the average value of channel e1

**TLOG.SUM ( )**

Syntax: TLOG.SUM (e1)

Result: Computes the summation of channel e1

**TLOG.P-P ( )**

Syntax: TLOG.P-P (e1)

Result: Computes the maximum value – minimum value of channel e1

**An Example of Computing Equations**

TLOG.MAX(01)+K01\*SQR(02)

**Examples of Computing Equations That are Not Allowed**

TLOG.AVE(01)+TLOG.AVE(02)

Reason: TLOG appears twice in one equation.

TLOG.AVE(ABS(01))

Reason: A computing element is used inside the parentheses.

**Rules for Writing an Equation (Common Items)**

Follow the rules below in writing the computing equations.

- Use up to 40 characters to write equations.
- The precedence of computing terms can be specified using parentheses.
- Specify the channels in the equation using channel numbers.
- You can use "01" or "1," for example, to specify one-digit numbers for channels, constants, communication input data, and conditions of the remote control terminals in equations.

Example: 01, 1, K01, K1, C01, C1, D01, D1

- The data value for the channel used in the equation, and for all channels greater in number than that channel, are substituted with data from the previous scan.
- Do not use more than 16 stacks (channel, K01 to K12, C01 to C12, D01 to D08) in one equation. Otherwise, a computation error may occur. The computed result is set to positive overflow (displayed as +\*\*\*\*\*\*) in this case.

Example: The number of stacks in the equation 01+K01\*(03+04\*K02) is five.

## 5.19 Setting the Timer Number and Sum Scale for TLOG Computation (/M1 Option)

Set the number of the timer used by the channel computing the TLOG. Also, set the [sum scale] that is used when determining the sum in TLOG.SUM. The timer specifications are set in the system mode (see section 4.7).

### Procedure

Press .

Twice press the soft key .

To display the setting screen press the soft key .

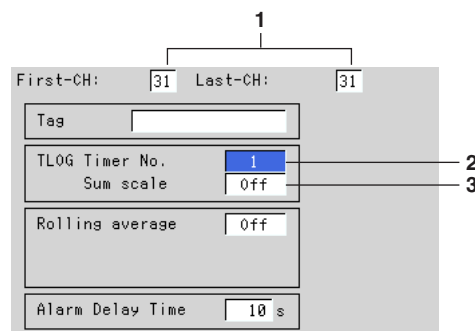

1. First-CH, Last-CH  
Select the desired channels (For the channels set here, other parameters shown in the above figure are also simultaneously set).
2. Timer No.  
Select the number of the timer (1, 2, or 3) specified in the system mode.
3. Sum scale  
When the channel is computing TLOG.SUM, select the scale unit from [Off], [/s], [/min], or [/h] (see section 1.7). You do not have to set this for channels that are not computing TLOG.SUM (leave it [Off]).

### Confirming Operation

To confirm the new settings, press the DISP/ENTER key.

To cancel the new settings, press the ESC key. A window appears for you to confirm the cancellation. Select [Yes] using the arrow keys and press the DISP/ENTER key.

## 5.20 Setting the Rolling Average (/M1 Option)

### Procedure

Press .

Twice press the soft key .

To display the setting screen press the soft key .

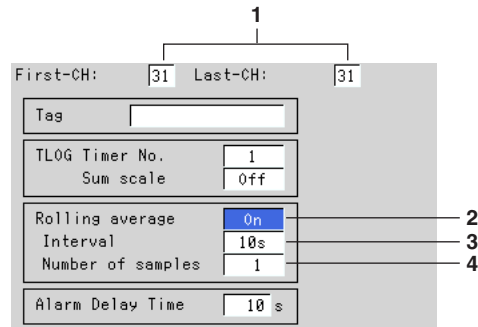

First-CH:	[31]	Last-CH:	[31]
Tag	[ ]		
TLOG Timer No.	[1]	Sum scale	[Off]
Rolling average	[On]	Interval	[10s]
Number of samples	[1]	Alarm Delay Time	[10 s]

- 1. First-CH, Last-CH**  
Select the desired channels (For the channels set here, other parameters shown in the above figure are also simultaneously set).
- 2. Rolling average**  
Select [On] or [Off]. If [On] is selected, [Interval] and [Number of samples] are displayed.  
[On]: Use rolling average  
[Off]: Do not use rolling average
- 3. Interval**  
Select the interval from the selections below. However, when the scan interval is set to 2 s, even if the sampling interval is set to 1 s, 3 s, 5 s, or 15 s, the sampling will be performed at 2 s, 4 s, 6 s, or 16 s.  
1 s, 2 s, 3 s, 4 s, 5 s, 6 s, 10 s, 12 s, 15 s, 20 s, 30 s, 1 min, 2 min, 3 min, 4 min, 5 min, 6 min, 10 min, 12 min, 15 min, 20 min, 30 min, 1 h
- 4. Number of samples**  
Select the number of data points used to compute the rolling average from integer values between 1 and 64.

### Confirming Operation

To confirm the new settings, press the DISP/ENTER key.

To cancel the new settings, press the ESC key. A window appears for you to confirm the cancellation. Select [Yes] using the arrow keys and press the DISP/ENTER key.

## 5.21 Setting the Calibration Correction (/CC1 Option)

Sets the segments for calibration correction using measured values and corresponding true values. Only allowed users can use this function (see section 4.4).

### Note

- If you change the [Mode], [Type], or [Range] of the measurement channel (see section 5.1), the calibration correction setting is reset.
- If you change the upper or lower limit of span or the upper or lower limit of scale on a measurement channel whose [Mode] is set to [Scale] or [Sqrt], the calibration correction setting is reset.
- The calibration correction cannot be set to the channels that are set to [Skip].

### Procedure

Press .

#### Models without the computation function (/M1 option)

Twice press the soft key .

To display the setting screen press the soft key .

#### Models with the computation function (/M1 option)

Three times press the soft key .

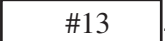
To display the setting screen press the soft key .

First-CH: 01		Last-CH: 01	
Number of set points 16			
	MES val	True val	
1	-2.000	-2.000	9
2	-2.000	-2.000	10
3	-2.000	-2.000	11
4	-2.000	-2.000	12
5	-2.000	-2.000	13
6	-2.000	-2.000	14
7	-2.000	-2.000	15
8	-2.000	-2.000	16
	MES val	True val	
	-2.000	-2.000	

1. First-CH/Last-CH  
Set the target channels.  
You can set consecutive channels whose range is set to the same value as the first channel.
2. Number of set points  
Select the number of points that make up the segments (2 to 16 including the start and end points) or [Off].  
Off: Do not perform calibration correction.



## 3. MES val

**When directly entering numeric values**

Press the [Input] soft key to display a window used to enter the value. Enter the value and press DISP/ENTER.

- **Selectable range for measured value**

- Channels set to scaling or square root computation  
–30000 to 30000  
The decimal point position is the same as for the scale lower limit.
- Other channels  
Measurable range of the selected range  
Example: –2.000 to 2.000 for [Volt], [2V]

**When entering current measured values**

Press the [Measure] soft key to set the measured value at that point.

**Note**

- If the measured value is less than or equal to the previous value, you cannot confirm the setting. An error message is displayed.
- If you change the following items, the [Measure] soft key cannot be used on the channel unless the changes are activated (save the settings and exit the engineering mode). Otherwise, an error message is displayed.
  - Input filter or moving average setting.
  - [Mode], [Type], or [Range] on the measurement channel.
  - The upper or lower limits of span, the upper or lower limits of scale, or the decimal point position on a measurement channel whose [Mode] is set to [Scale] or [Sqrt].
- If you press the [Measure] soft key when setting multiple channels simultaneously, the measured value of the first channel are set to all channels.

## 4. True val

Press the [Input] soft key to display a window used to enter the value. Enter the value and press DISP/ENTER.

The selectable range for true value is the same as that for the measured value.

**Confirming Operation**

To confirm the new settings, press the DISP/ENTER key.

To cancel the new settings, press the ESC key. A window appears for you to confirm the cancellation. Select [Yes] using the arrow keys and press the DISP/ENTER key.

**Explanation****Changing the Settings While Data Acquisition Is in Progress**

To change the calibration correction setting during data acquisition, this operation must be enabled in advance. In addition, a message can be written when the calibration correction setting is changed during data acquisition. For these setup procedures, see section 4.14.

When the calibration correction setting is changed during data acquisition, a log for this operation is recorded (see appendix 5).

## 5.22 Setting the DST

Set the DST start time and end time. When you use the DST function, set the time difference from GMT correctly (see section 4.10).

### Procedure

Press .

Press the soft key .

Press the [Daylight savings time] soft key. The setup screen is displayed.

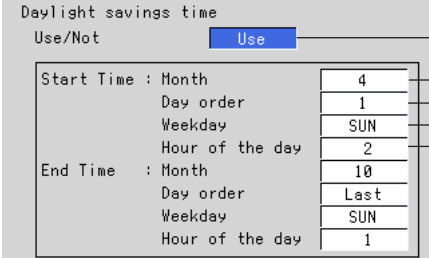

Daylight savings time	
Use/Not	Use <span style="float: right;">1</span>
Start Time : Month	4 <span style="float: right;">2</span>
Day order	1 <span style="float: right;">3</span>
Weekday	SUN <span style="float: right;">4</span>
Hour of the day	2 <span style="float: right;">5</span>
End Time : Month	10
Day order	Last
Weekday	SUN
Hour of the day	1

1. Use/Not  
Set whether to use DST. If Use is selected, the time entry boxes appear.

#### Start time

The DST start time. Set as in "2nd hour on the first Sunday in April."

2. Month  
Select the month between January [1] and December [12].
3. Day order  
Set the number of the week in the month in which the day specified by [Weekday] falls. Select from [1] (1st), [2] (2nd), [3] (3rd), [4] (4th), and [Last].
4. Weekday  
Set the day of the week. Select from [SUN], [MON], [TUE], [WED], [THU], [FRI], and [SAT].
5. Hour of the day  
Set the hour.

Pressing the [Input] soft key displays a window used to enter the value. Enter the hour as in [1] hour, [2] hour, ..., [23] hour and press DISP/ENTER. For the procedures for entering values, see section 3.6, "Entering Numbers and Characters."

#### End time

The DST end time. Set as in "1st hour on the first Sunday in October." The method of setting [Month], [Day order], [Weekday], and [Hour of the day] are the same as with [Start time].

#### Confirming Operation

To confirm the new settings, press the DISP/ENTER key.

To cancel the new settings, press the ESC key. A window appears for you to confirm the cancellation. Select [Yes] using the arrow keys and press the DISP/ENTER key.

### Explanation

#### Start time and End time

You cannot set the same value to [Start time] and [End time].

## 5.23 Saving/loading the Setup Data

### Saving Setup Data

The setup data set in the engineering mode and system mode (including the login information) is saved to the external storage medium.

#### Procedure

Press .

Press the soft key .

Press  soft key to display the [Save/Load, Clear data] menu screen.

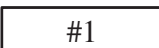
Press  soft key to display the [Save settings] screen.

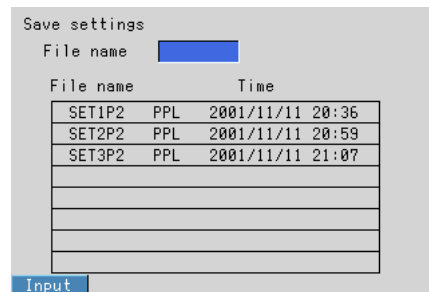

File name	Time
SET1P2 PPL	2001/11/11 20:36
SET2P2 PPL	2001/11/11 20:59
SET3P2 PPL	2001/11/11 21:07

1. Enter the file name (up to eight characters) in the [File name] box and press the DISP/ENTER key. For the procedures related to entering a string, see section 3.6, "Entering Values and Strings."  
Press the ESC key to cancel the operation and return to the [Save/Load] menu.

#### Note

- Setup data file is automatically assigned .PPL extension.
- The following characters or strings cannot be used as file names.  
"AUX," "CON," "PRN," "NUL," "CLOCK," character strings that include a space or spaces

2. Press the DISP/ENTER key to save the setup data to the root directory on the external storage medium. The name of the saved file is displayed in the file list section on the right side.  
If a file with the same name as you entered exists on the external storage medium, a message will appear to confirm overwriting. To overwrite the file, select [Yes] and press the DISP/ENTER key.

### Loading Setup Data

Loads only the data that was set in the engineering mode from the setup file (file with .PPL extension) on the external storage medium to the DX100P. Parameters of the loaded data that contradict with the system mode information on the DX100P are not retrieved. When executed, the loaded data are activated, and the system returns to the operation mode.

**Procedure**

Press .

Press the soft key .

Press  soft key to display the [Save/Load, Clear data] menu screen.

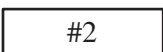
Press  soft key to display the [Load settings] screen.

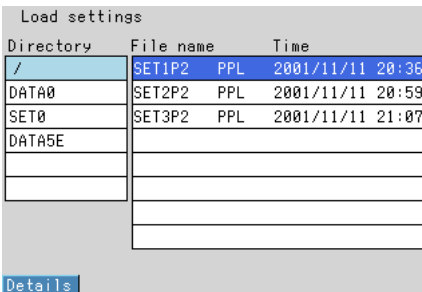

Directory	File name	Time
/	SET1P2 PPL	2001/11/11 20:36
DATA0	SET2P2 PPL	2001/11/11 20:59
SET0	SET3P2 PPL	2001/11/11 21:07
DATA5E		

Details

- Using the up and down arrow keys, select the directory (root directory [/] or [SET0] directory) containing the setup file shown in the [Directory name] box. A list of files in the selected directory is displayed in the right column.
- Press the right arrow key to move the cursor on to the file list. Press the up or down arrow key to select the setup file to be loaded. Press the ESC key to cancel the operation and return to the [Save/Load] menu.
- Press the [Details] soft key to view the information about the file. For details, see section 4.11.
- Press the DISP/ENTER key to return to the operation mode. The loaded setup data is activated.

At this point, **if the loaded setup data is not identical to the setup data on the DX100P, the setup file is saved to the external storage medium, and the log of setting change is saved to the setting change log** (audited trail function, see section 1.5).

**Note**

- If “damage check” indicates “damaged,” the setup data cannot be loaded.
- If the loaded setup data are void, check the error log. For the procedure for displaying the error log, see section 8.9.

## 5.24 Saving the Data in the Internal Memory to the External Storage Medium Using Keys

Save the data in the internal memory to the external storage medium when data acquisition is stopped.

This operation can be carried out only by an administrator.

### Procedure

Press . The engineering mode menu screen appears.

Press the  soft key. The menu screen is displayed.

Save/Load	
#1	Save settings
#2	Load settings
#3	Save data to media

Press the  soft key.

The data in the internal memory is saved to the external storage medium.

### Explanation

#### Data That Are Saved

The display data, event data, manual sampled data, TLOG data, and report data in the internal memory are saved. For details, see section 1.4.

#### Save Destination Directory

- The data saved using this method is saved to the following directory.  
"The specified directory name".A\*\* (where \*\* is a sequence number)
- The sequence number of the directory name is incremented by 1 each time the data save operation is carried out.

Example: If the specified directory name is [Data0], the data is saved to DATA0.A00 on the first key operation and DATA0.A01 on the second key operation.

#### Note

- This operation cannot be carried out if the engineering mode setting is changed but the change has not been applied.
- Data storage is cancelled when there is no free space on the storage medium.
- If a directory of the same name exists on the storage medium for saving data, an error message is displayed, and the save operation is terminated (data is not saved).
- You cannot carry out other operations while the data is being saved.
- If you change the directory name for saving the data, the sequence number is reset to 0.

# 6.1 Login/Logout

## Logging in

### Procedure

#### Logging in for the First Time

1. Press the FUNC key. A window appears for you to enter the user name.
2. Enter the user name and press the DISP/ENTER key.

For the procedures for entering values and strings, see section 3.6, "Entering Values and Strings."

If the use of the user ID is enabled, a window appears for you to enter the user ID. Proceed to step 3.

If the use of the user ID is disabled, a window appears for you to enter the password. Proceed to step 4.

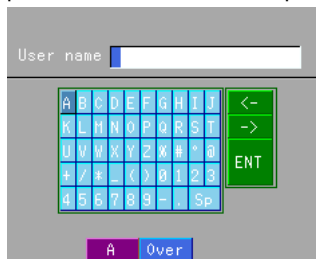

3. Enter the user ID and press the DISP/ENTER key. A window appears for you to enter the password.



4. Enter the default password for the DX100P and press the DISP/ENTER key. A window appears for you to enter a new password.



User	Default Password
Administrator 1	Admin1
Administrator 2	Admin2
Administrator 3	Admin3
User 1	User01
User 2	User02
:	:
User 90	User90

## 6.1 Login/Logout

5. Enter the new password in the same fashion as step 2 and press the DISP/ENTER key. A window appears for you to confirm the password.



### Note

- The combinations of user IDs and passwords that are identical to those specified by other users or those that have been registered in the past cannot be specified.
- Set the password using 6 to 8 characters. Spaces cannot be used for the password.

6. Enter the password that you entered in step 5 in the same fashion as step 2 and press the DISP/ENTER key. The window disappears and you are logged in.

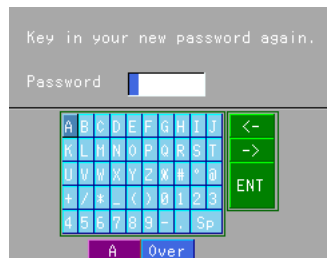

### Logging in after the First Time

1. Press the FUNC key. A window appears for you to enter the user name.
2. Enter the user name and press the DISP/ENTER key.

For the procedures for entering values and strings, see section 3.6, "Entering Values and Strings."

If the use of the user ID is enabled, a window appears for you to enter the user ID. Proceed to step 3.

If the use of the user ID is disabled, a window appears for you to enter the password. Proceed to step 4.



3. Enter the user ID in the same fashion as step 2 and press the DISP/ENTER key. A window appears for you to enter the password.



- Enter the password in the same fashion as step 2 and press the DISP/ENTER key. The window disappears and you are logged in.



### "User locked" and corrective action

If you repeat the operation of entering a wrong password and pressing the DISP/ENTER key three times, the user is invalidated and can no longer log in. The status display section shows a User Locked icon.



#### • Clearing the User Locked Icon (Executable Only by the Administrator)

- Log in as an administrator.
- Press the FUNC key to display the soft key menu.
- Press the [User Locked ACK] soft key to clear the User Locked icon.

#### • Clearing the Invalidated User/Log in by the Invalidated User

- The administrator sets the password of the invalidated user to the default password. For the operating procedure, see section 4.4.
- The invalidated user sets the password according to the procedure "Logging in for the First Time."

### Note

If the passwords of all administrators are invalidated, you can no longer log in as an administrator (if a user is registered, you can still log in as a user).

**Make sure to keep track of passwords to avoid such situation.** If you find yourself in such situation, contact your nearest YOKOGAWA dealer.

## Logging Out

### Procedure

#### Operation Using the FUNC Key

- Press the FUNC key to display the FUNC key menu.
- Press the [Logout] soft key to log out.



#### Logging Out Automatically

If the auto logout function is enabled (see section 4.4) and there is no key operation for the specified time, you will be automatically logged out.



## 6.2 Executing Memory Start/Memory Stop

### Executing Memory Start

#### Procedure

1. Press the START key. The start screen is displayed.

The screenshot shows a terminal-style interface for starting memory storage. At the top, it asks 'Press Start to begin storage with these setting?' and has a blue 'Start' button. Below are three header lines: 'Header1: Manager ABC2001', '2: Supervisor None', and '3: Operator ope1'. There are three input fields: 'Batch No.' (empty), 'Lot No.' (containing '0'), and 'Comment 1:' (empty). Below 'Comment 1:' are two more empty input fields labeled '2:' and '3:'. Labels on the right side point to the 'Start' button, the three header lines, the 'Batch No.' field, the 'Lot No.' field, and the three comment fields.

#### Entering the Batch Number, Lot Number, and Comment

Perform the following operations as necessary.

2. Using the arrow keys, move the cursor (blue) to the batch number, lot number, or comment 1, 2, or 3 box and press the [Input] soft key. Enter the batch number, lot number, or comment 1, 2, or 3 and press the DISP/ENTER key.  
Batch number: Up to 32 characters  
Lot number: Up to 8 digits  
Comment 1, 2, and 3: Up to 32 characters  
For the procedures for entering values and strings, see section 3.6, "Entering Values and Strings."

#### Starting Operations

3. Using the arrow keys, move the cursor (blue) to the [START] button and press the DISP/ENTER key.  
The following operations start.
  - Acquisition of the display data or event data to the internal memory  
The icon of the status display section changes to indicate data acquisition to the internal memory is in progress.
  - Waveform display on the trend screen.
  - On models with the computation function (/M1 option)
    - Computation  
The computation icon appears in the status display section.
    - Report

#### Note

If a user that is not allowed to use [Batch] operation in login mode settings (see section 4.4) is logged in, the user cannot enter the batch number, lot number, and comment.

## Executing Memory Stop

### Procedure

1. Press the STOP key. A confirmation window below opens.

### Note

If there are alarms that have not been acknowledged using the alarm ACK operation when you press the STOP key, a message "Please acknowledge all active alarms before stopping this record" appears. Cancel the memory stop operation as necessary (see step 3) and perform alarm ACK operation.

If Memory Stop is executed without alarm ACK operation, the alarm ACK operation is not recorded in the batch file. If the alarm ACK operation is performed after Memory Stop, the operation is recorded in the next batch file.

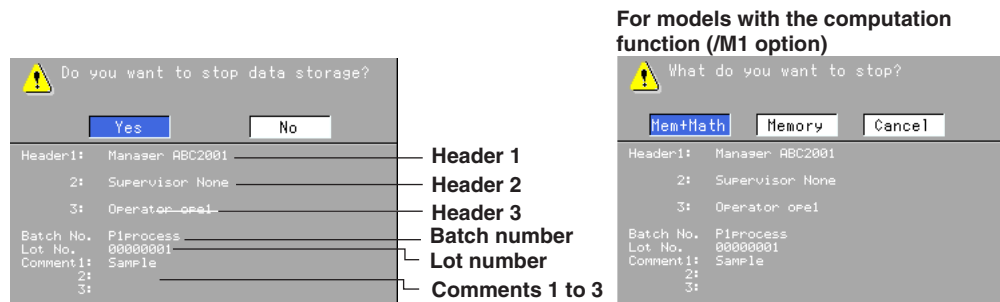

2. Confirm the batch information such as the header, batch number, lot number, and comments.
3. Select an item using the arrow keys and press the DISP/ENTER key.
  - **For Models without the Computation Function (/M1 Option), or When a user who is not allowed to start/stop computation logged into a model with the Computation Function .**
    - Yes:** Acquisition of the display/event data to the internal memory stops. The icon of the status display section changes to indicate data acquisition to the internal memory is stopped.
    - No:** Acquisition of the display/event data to the internal memory continues.
  - **For Models with the Computation Function (/M1 Option).**
    - Mem+Math:** Acquisition of the display/event data to the internal memory and computation stop. If the report function is being used, it is also stopped. The icon of the status display section changes to indicate data acquisition to the internal memory is stopped.
    - Memory:** Acquisition of the display/event data to the internal memory stops. If the report function is being used, it is also stopped. The icon of the status display section changes to indicate data acquisition to the internal memory is stopped.
    - Cancel:** Acquisition of the display/event data to the internal memory and computation continue.

If the data acquisition to the internal memory is stopped, **the display data or event data is saved to the external storage medium.** If the report function is being used, a report data is created and saved to the external storage medium.

**Make sure to back up the saved data.**

If [batch stop sign record] is specified and a user that has sign authority executes Memory Stop, the sign record screen appears. Proceed to section 6.3.

## 6.3 Signing Display Data/Event Data

Sign the display data and event data using the sign record screen.

- If [batch stop sign record] is specified and a user that has sign authority executes Memory Stop, the sign record screen appears.
- The sign record screen appears when the operation to load the display data or event data on the external storage medium (see section 8.7) is executed.

### Note

If the type of process is [Batch] and a single batch data is divided into multiple files, the [Batch stop sign record] setting is invalid (you cannot sign using the DX100P). Use the DAQSIGNIN that came with the package to sign the data.

### Procedure

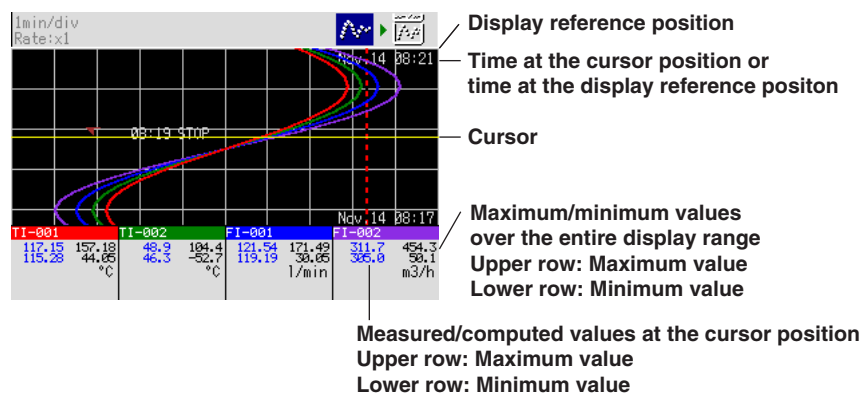

The following operations can be carried out on the sign record screen.

- **Read the time and measured/computed values at the cursor position**
- **Scroll the waveforms**
- **Change the range of displayed waveforms**

For details on the operations above, see section 7.5, "Using the Historical Trend."

### Expanding/Reducing the Time Axis

1. Press the DISP/ENTER key to display the screen menu.
2. Using the up and down arrow keys, move the cursor to [TIME AXIS]. Press the right arrow key to display the sub menu.

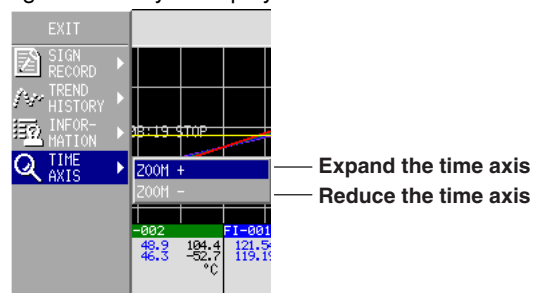

3. Select [ZOOM+] or [ZOOM-] using the up and down arrow keys.

- Press the DISP/ENTER key to switch to the waveform display with the time axis expanded or reduced.  
 Display data: 2 times the trend display to 1/60 minimum  
 Event data: Reduction only, up to 1/60 minimum  
 The minimum magnification and the factor by which the display can be expanded or reduced with one operation varies depending on the display update rate for the display data and on the sampling interval for the event data.  
 To close the menu without switching the screen, press the ESC key.

**Changing the Display**

- Press the DISP/ENTER key to display the screen menu.
- Using the up and down arrow keys, move the cursor to [TREND HISTORY]. Press the right arrow key to display the sub menu.

**Sub menu of "TREND HISTORY"**

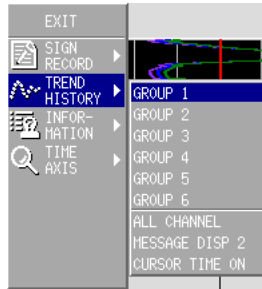

- GROUP 1: Displays group 1
- GROUP 2: Displays group 2
- GROUP 3: Displays group 3
- GROUP 4: Displays group 4
- GROUP 5: Displays group 5
- GROUP 6: Displays group 6
- ALL CHANNEL:  
Displays the waveform of all the channels (See "Explanation" in section 7.2)
- GROUP CHANNEL:  
Displays the waveforms of the channels registered to groups
- MESSAGE DISP 2:  
Switches to message display 2.
- MESSAGE DISP 1:  
Switches to message display 1. (see "Explanation" in section 7.2)
- CURSOR TIME ON:  
Displays the time at the cursor position.
- CURSOR TIME OFF:  
Displays the time at the display reference position

- Select the sub menu item using the up and down arrow keys.
- Press the DISP/ENTER key to execute the display. To close the menu without switching the screen, press the ESC key.

**Confirming the Information**

- Press the DISP/ENTER key to display the screen menu.
- Using the up and down arrow keys, move the cursor to [INFORMATION]. Press the right arrow key to display the sub menu.

**Sub Menu of "INFORMATION"**



- OPERATION LOG:  
Displays the operation log
- ALARM SUMMARY:  
Displays the alarm summary
- ALM ACK SUMMARY:  
Displays the alarm ACK summary
- MESSAGE SUMMARY:  
Displays the message summary
- INFORMATION ON:  
Displays the file information

- Select the sub menu item using the up and down arrow keys.
- Press the DISP/ENTER key to display the selected information. To close the menu without switching the screen, press the ESC key.

**Operation Log**

The operation log displays the log of operations from Memory Stop to the next Memory Stop.

The number of the log displayed on the last line  
 Total number of logs

(0012/0050)	Time	Action	User Name	
Nov.19	10:57:37	Snapshot	ABC2001	
Nov.19	10:54:48	AlarmACK	ABC2001	[R]
Nov.19	10:54:41	Manual	ABC2001	[R]

Operation type (see page 1-35)

Name of the user who performed the operation  
 Operation information (see appendix 5)  
 Date and time when operation was performed

**Alarm Summary**

(020/023)	Channel	Type	Alarm IN Time	Alarm OUT Time
●	TI-001	1H	Nov.14 08:20:40	Nov.14 08:21:09
●	FI-002	1H	Nov.14 08:20:19	Nov.14 08:21:26
●	FI-001	1R	Nov.14 08:18:53	Nov.14 08:19:55
●	FI-002	2L	Nov.14 08:16:54	Nov.14 08:18:39
●	TI-001	1H	Nov.14 08:14:28	Nov.14 08:14:57

Date and time of release  
 Date and time of occurrence  
 Cursor (selects the alarm)

**Alarm ACK Summary**

If the alarm display is set to [Hold], the log of alarm ACK operations is displayed.

(020/023)	Channel	Type	ACK Time	User Name
●	TI-001	1H	Nov.14 08:21:34	ABC2001
●	FI-002	1H	Nov.14 08:21:42	ABC2001
●	FI-001	1R	Nov.14 08:21:38	ABC2001
●	FI-002	2L	Nov.14 08:21:45	ABC2001
●	TI-001	1H	Nov.14 08:16:03	ABC2001

Date and time of alarm ACK operation

**Message Summary**

(004/004)	Message / Time	User Name
STOP	Nov.14,2001 08:19:50	ABC2001
Material2	Nov.14,2001 08:17:12	ABC2001
Material1	Nov.14,2001 08:12:24	ABC2001
START	Nov.14,2001 08:11:47	ABC2001

Cursor (selects the message)

- **Recalls the Historical Trend for When the Alarm Occurred / Recalls the Historical Trend for When the Message Was Written.**

The operation described here is for the case when alarm summary or message summary is being displayed.

5. Move the cursor using the up and down arrow keys and select the alarm or message for which the historical trend is to be displayed.
6. Press the DISP/ENTER key to display the screen menu.
7. Press the right arrow key to display the sub menu. [TREND HISTORY] is selected in the sub menu.

EXIT	Type Alarm IN
SIGN RECORD	1H Nov.14 08:
TREND HISTORY	1R Nov.14 08:
INFORMATION	2L Nov.14 08:
TIME AXIS	1H Nov.14 08:
	1R Nov.14 08:
	2L Nov.14 08:

OPERATION LOG  
 ALARM SUMMARY  
 ALM ACK SUMMARY  
 MESSAGE SUMMARY  
 INFORMATION ON  
 JUMP TO HISTORY

Displays the historical trend containing the selected alarm or message

8. Press the DISP/ENTER key to display the historical trend. To close the menu without switching the screen, press the ESC key.

• **Confirming the File Information**

Select [INFORMATION ON] from the sub menu and press the DISP/ENTER key to display the file information. You can switch the file information window using the left and right arrow keys.

**Basic information**

```

Process1-00000001
File Name (Data Kind) : Y1400071.DBD (DISP)
Serial No. : 12WB24024
Start Time : Nov.14.2001 08:07:52
Start User Name : ABC2001
End Time : Nov.14.2001 08:21:48
End User Name : ABC2001

Header 1 : Manager ABC2001
Header 2 : Supervisor None
Header 3 : Operator opel
                    
```

**File name (Data type)\*  
(DISP: Display data  
EVENT: Event data)**

**Serial number of the DX100P  
used for data acquisition**

**Date & time and the user  
name at Memory Start/Stop**

**Headers**

**Comments, date and time, user name**

```

Comment 1 : Sample225
User Name : ABC2001
Time : Nov.14.2001 07:57:18

Comment 2 :
User Name :
Time :

Comment 3 :
User Name :
Time :
                    
```

**Sign record**  
Date and time, result (pass/fail), comments

```

Sign record 1:
Time :
Result :
Comment :

Sign record 2:
Time :
Result :
Comment :

Sign record 3:
Time :
Result :
Comment :
                    
```

\* For data that is saved using keys while data acquisition is stopped, the file name and data type appear in red. See page 1-30.

**Signing (Adding Approval Information)**

**Note**

Make sure to confirm the measured/computed data and alarm information before signing the data.

1. Press the DISP/ENTER key to display the screen menu.
  2. Move the cursor to [SIGN RECORD]\* using the up and down arrow keys.
- \* This menu is displayed when the user is assigned a sign authority level.

**When Logged in as an Administrator**

Press the right arrow key to display the sub menu. Select [Sign1], [Sign2], or [Sign3] using the up and down arrow keys.

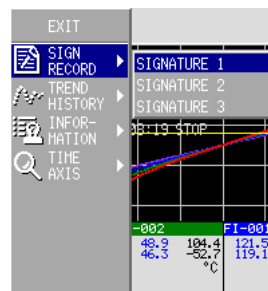

— Add approval information to Sign1

— Add approval information to Sign2

— Add approval information to Sign3

-002			F1-001		
48.9	104.4	121.5			
46.3	-52.7	119.1			
°C					

### 6.3 Signing Display Data/Event Data

#### When Logged in as a User

If you are logged in as a user, you can sign at the registered authority level only. The sub menu [Sign1] to [Sign3] does not appear.

3. Press the DISP/ENTER key. A confirmation window is displayed. To close the menu without switching the screen, press the ESC key.
4. Select [Yes] using the arrow keys and press the DISP/ENTER key.

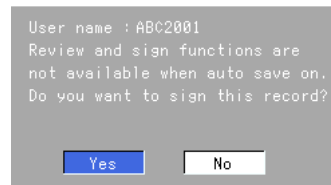

For data that is saved using keys while data acquisition is stopped, the text appears in red. See page 1-30.

If the use of the user ID is enabled, a window appears for you to enter the user ID. Proceed to step 5.

If the use of the user ID is disabled, a window appears for you to enter the password. Proceed to step 6.

5. Enter the user ID and press the DISP/ENTER key. A window appears for you to enter the password.

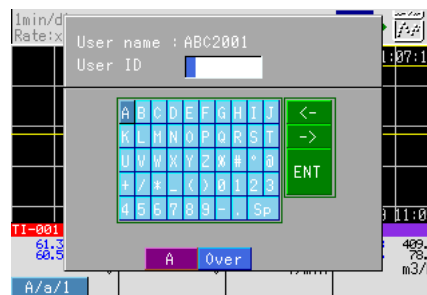

6. Enter the password and press the DISP/ENTER key. A window appears for you to select [Pass] or [Fail].

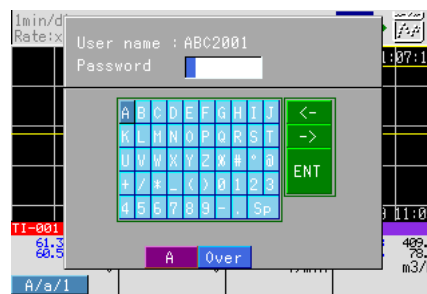

#### Note

If you repeat the operation of entering a wrong password and pressing the DISP/ENTER key **three times**, the user is invalidated. Have the administrator set a default password and reset the password according to "Logging in for the First Time."

7. Select [Pass] or [Fail] using the arrow keys and press the DISP/ENTER key. A window appears for you to enter a comment.

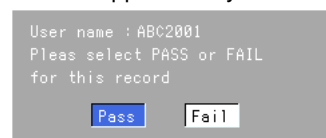

**Note**

After confirming the data, select [Pass] if it is OK or [Fail] if it is not. Define the pass/fail criteria for each application and for each user.

8. Enter a comment (up to 32 characters) and press the DISP/ENTER key. A confirmation window opens.



9. Select [Yes] using the arrow keys and press the DISP/ENTER key. The approval information is added to the data file on the external storage medium. The operation screen is displayed.

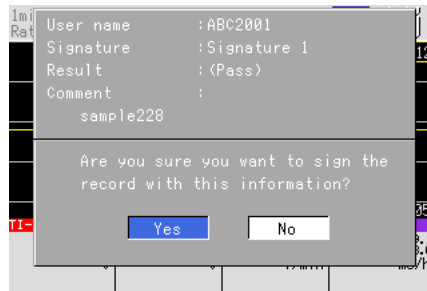

**Note**

While the DX100P is writing the approval information to the data file in the external storage medium, and the file is being transferred using FTP (when the file transfer function through FTP is used), the keys on the DX100P do not operate. If a remote control signal is received, the action is executed after the above mentioned processing ends.

**Exiting from the Sign Record Screen without Signing**

1. Press the DISP/ENTER key to display the screen menu.
2. Move the cursor to [ESC] using the arrow keys and press the DISP/ENTER key to return to the original operation screen.

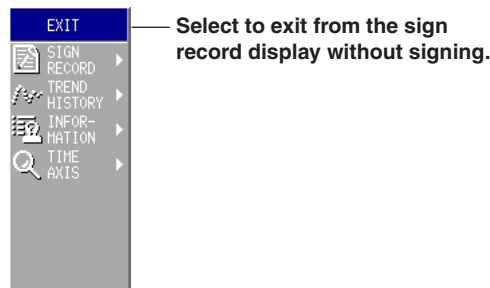



# 7.1 Displaying and Switching Operation Screens

The screen is switched using the arrow keys and the DISP/ENTER key.

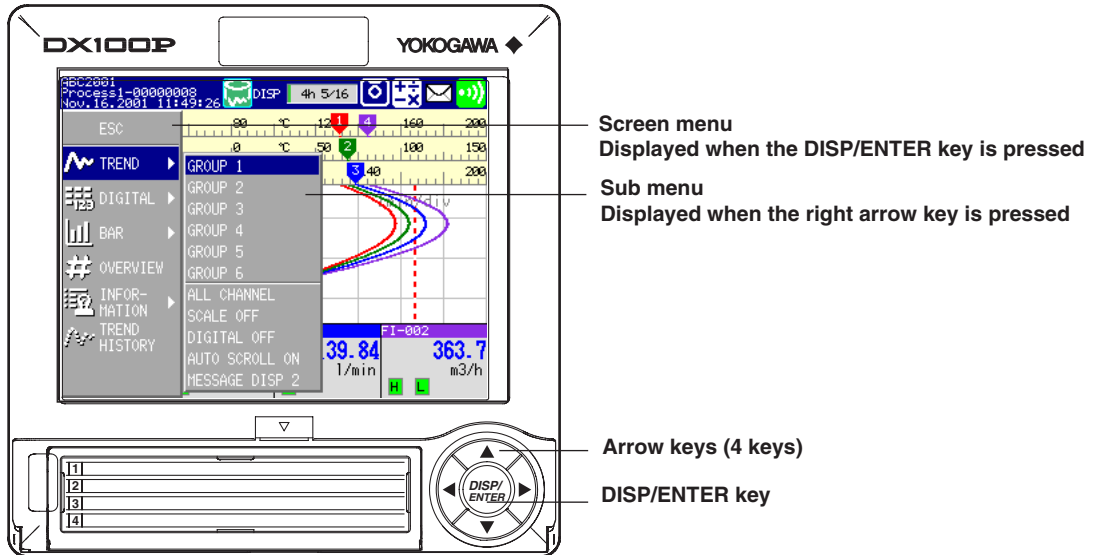

## 7.1 Displaying and Switching Operation Screens

### Procedure

#### Switching the Screen

Carry out the following procedure to switch the displayed screen.

1. Press the DISP/ENTER key to display the screen menu.
2. Select the type of screen to be displayed using the up and down arrow keys.
3. For items with a ▶ mark, you can display the sub menu by pressing the right arrow key.
4. Select the screen to be displayed using the up and down arrow keys.
5. Press the DISP/ENTER key to display the screen.

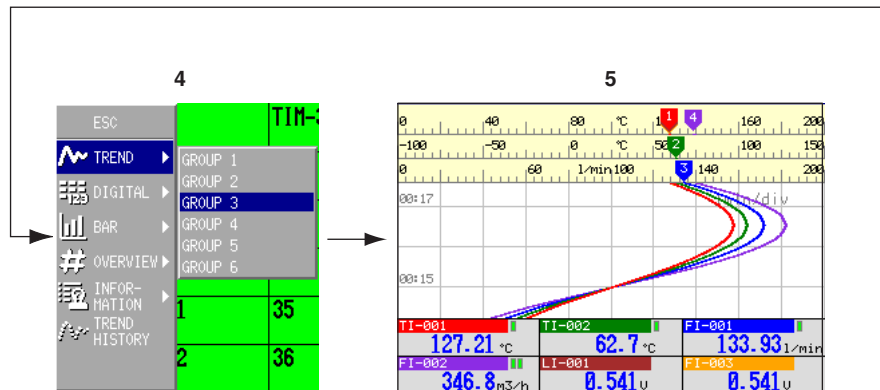
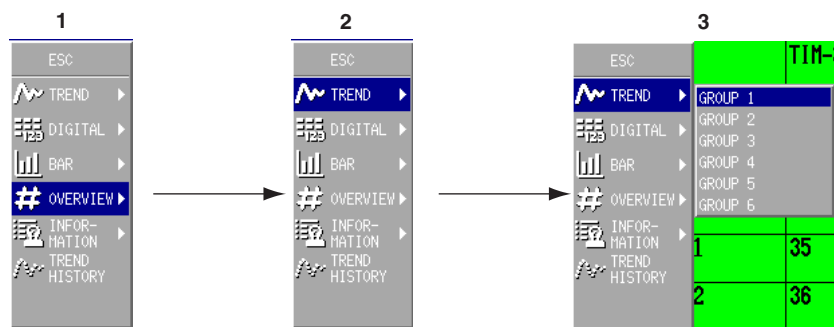

## 7.2 Using the Trend, Digital, and Bar Graph Screens

### Trend Screen

#### Procedure

#### Changing the Display

1. Press the DISP/ENTER key to display the screen menu.
2. Press the right arrow key to display the sub menu.
3. Select the sub menu item using the up and down arrow keys.

#### Sub menu of the trend screen

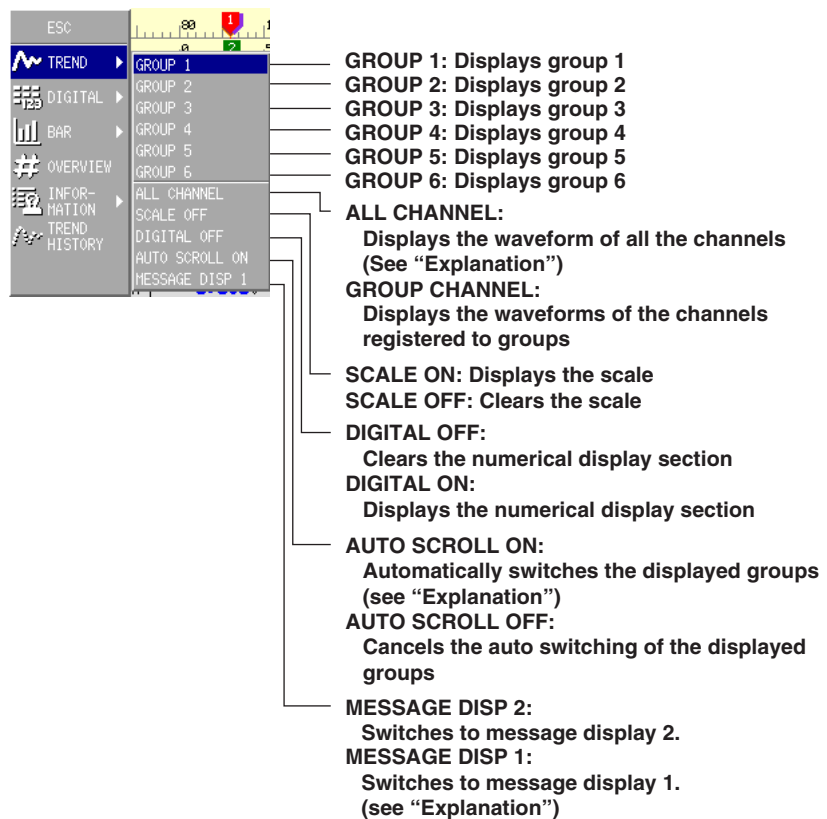

4. Press the DISP/ENTER key to execute the display. To close the menu without switching the screen, press the ESC key.

#### Starting the Waveform Display of the Trend Display/Stopping the Waveform Update

The operation for starting and stopping the waveform display of the trend display is the same as the operation for Memory Start and Memory Stop. When Memory Start is executed, waveforms are displayed; when Memory Stop is executed, waveforms are not updated. For the operating procedure, see section 6.2.

#### Writing Messages

See section 8.2.

## 7.2 Using the Trend, Digital, and Bar Graph Screens

### Explanation

#### Waveform Display during All Channel Display or Group Display

In group display, the waveforms of channels that are assigned to the group (see section 5.9) and are set to display the trend (see section 4.3) are displayed.

In **all channel display**, the waveforms of all channels that are set to display the trend (see section 4.3) are displayed on the current group display.

Condition Assigned to Groups <sup>*1</sup>	Trend Display/Data Storage Specification <sup>*2</sup>	Trend's Waveform Display	
		During Group Display	During All Channel Display
Yes	Yes	Display	Display
Yes	None	Don't display	Don't display
None	Yes	Don't display	Display
None	None	Don't display	Don't display

\*1 Whether or not the channel is assigned to a group.

\*2 Whether or not the channel is set to display the trend and store the data.

#### Trend all channel display example (vertical display)

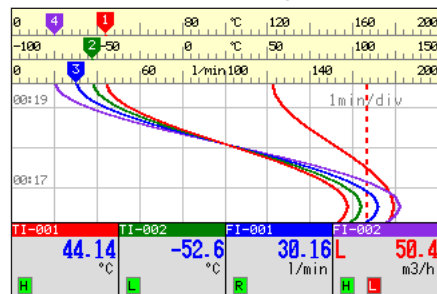

Except for the waveform, all information displayed on the screen corresponds to the group that was being displayed before switching to the all channel display.

The waveforms of all the channels set to display the trend are displayed.

#### Auto Switching of Groups

When [AUTO SCROLL ON] is selected, the displayed group on the trend, digital, and bar graph displays can be automatically switched at a specified interval. In each display, the displayed group rotates from group 1 to group 6. You can select 5 s, 10 s, 20 s, 30 s, and 1 min for the switch interval. For the procedure related to setting the switch interval (scroll time), see section 5.13.

#### Displaying Messages

You can switch between the two message display formats as shown below by selecting [MESSAGE DISP 1] or [MESSAGE DISP 2].

##### Message display 1

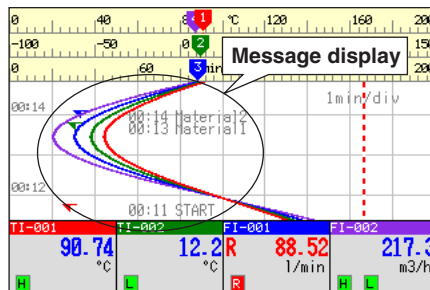

##### Message display 2

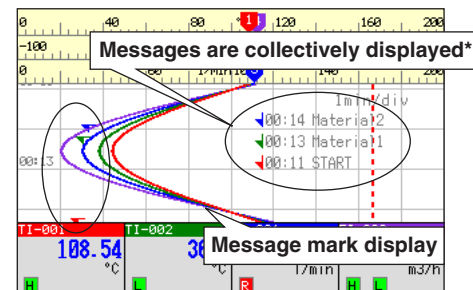

\* The number of lines that can be displayed varies depending on the trend display direction and the number of scales displayed.  
Vertical: 6 lines max., horizontal: 3 lines, horizontal (type 2): 2 lines

## Digital Screen

### Procedure

#### Changing the Display

1. Press the DISP/ENTER key to display the screen menu.
2. Press the right arrow key to display the sub menu.
3. Select the sub menu item using the up and down arrow keys.

#### Sub menu of the digital screen

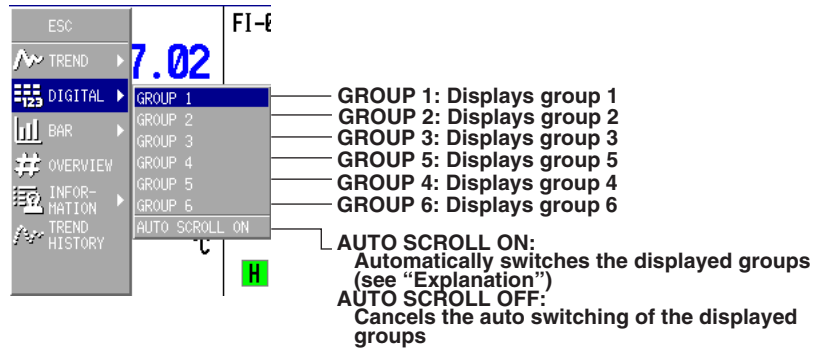

4. Press the DISP/ENTER key to execute the display.  
To close the menu without switching the screen, press the ESC key.

## Bar Graph Screen

### Procedure

#### Changing the Display

1. Press the DISP/ENTER key to display the screen menu.
2. Press the right arrow key to display the sub menu.
3. Select the sub menu item using the up and down arrow keys.

#### Sub menu of the bar graph screen



**GROUP 1: Displays group 1**  
**GROUP 2: Displays group 2**  
**GROUP 3: Displays group 3**  
**GROUP 4: Displays group 4**  
**GROUP 5: Displays group 5**  
**GROUP 6: Displays group 6**

**AUTO SCROLL ON:**  
Automatically switches the displayed groups (see "Explanation")

**AUTO SCROLL OFF:**  
Cancels the auto switching of the displayed groups

4. Press the DISP/ENTER key to execute the display.  
To close the menu without switching the screen, press the ESC key.

## Changing the Displayed Group Using the Arrow Keys

### Procedure

Press the right arrow key while displaying the trend, digital, or bar graph screen to rotate the displayed group from group 1 to group 6.

Press the left arrow key to rotate the displayed group in reverse order.

## Switching the Trend, Digital, and Bar Graph Screen Using the Arrow Keys

### Procedure

Press the down arrow key while displaying the trend, digital, or bar graph screen to switch the screen in the order trend, digital, bar graph, trend, and so on.

Press the up arrow key to switch the screen in reverse order.

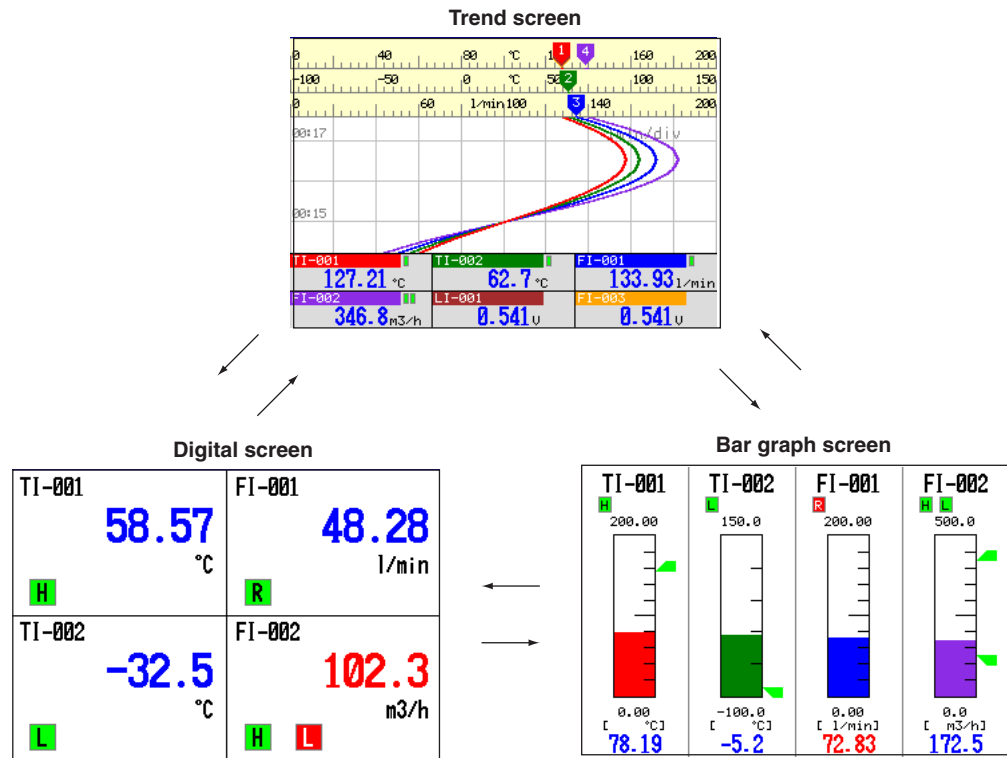

## 7.3 Using the Overview Screen

### Procedure

#### Changing the Display

1. Press the DISP/ENTER key to display the screen menu.
2. Press the right arrow key to display the sub menu.
3. Select the sub menu item using the up and down arrow keys.

#### Sub menu of the overview screen

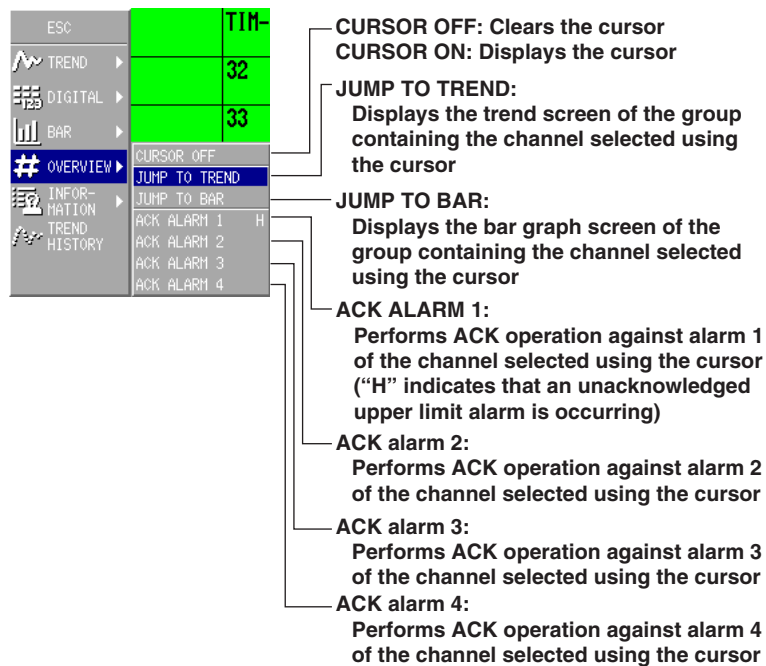

4. Press the DISP/ENTER key to execute the display.  
To close the menu without switching the screen, press the ESC key.

#### Releasing Alarm Display/Relay Output (Option) of Individual Alarms (Alarm ACK Operation)\*

The operation described here is for the screen with the cursor displayed.

1. Move the cursor using the arrow keys and select the channel on which the alarm is occurring.
2. The alarm display/relay output is released<sup>2</sup> by performing the procedure as described in "Changing the Display."

\*1 Operation when the use of alarm ACK operation (see section 4.1) is enabled.

\*2 For the procedure in releasing the alarm display/relay output of all alarms and a description on the alarm display and output relay behavior, see section 8.11.

#### Switching to the Trend/Bar Graph Display Containing the Channel Specified Using the Cursor

The operation described here is for the screen with the cursor displayed.

1. Move the cursor using the arrow keys and select the channel.
2. Switch to the trend display or bar graph according to the procedure described in "Changing the Display."



## 7.4 Using the Information Screen (Alarm Summary, Alarm ACK Summary, Message Summary, and Memory Summary)

### Procedure

#### Changing the Display

1. Press the DISP/ENTER key to display the screen menu.
2. Press the right arrow key to display the sub menu.
3. Select the sub menu item using the up and down arrow keys.

#### Sub menu of the information screen

ESC	00:50 :
TREND	4/100 : Jan.01 00:25
DIGITAL	01/400 : Jan.01 00:25
BAR	DISPLAY DATA
OVERVIEW	Start End Time
INFORMATION	00003
TREND	100 Jan.01 00:26:18
HISTORY	00002
	100 Jan.01 00:25:14
	00001
	100 Jan.01 00:22:06
	ALARM SUMMARY
	ALM ACK SUMMARY
	MESSAGE SUMMARY
	MEMORY SUMMARY
	JUMP TO HISTORY
	JUMP TO REPORT

- ALARM SUMMARY:**  
Displays the alarm summary
- ALM ACK SUMMARY:**  
Displays the alarm ACK summary
- MESSAGE SUMMARY:**  
Displays the message summary.
- Memory summary:**  
Displays the memory summary
- JUMP TO HISTORY:**  
When alarm summary is displayed  
Displays the historical trend for when the alarm selected using the cursor occurred  
When message summary is displayed  
Displays the historical trend for when the message selected using the cursor was written  
When memory summary is displayed  
Displays the historical trend for the data selected using the cursor
- JUMP TO REPORT:**  
(Only when memory summary is displayed)  
Displays the most recent report data.

4. Press the DISP/ENTER key to execute the display.  
To close the menu without switching the screen, press the ESC key.

## 7.4 Using the Information Screen (Alarm Summary, ....., and Memory Summary)

### Alarm Summary

#### Procedure

#### Recalling the Historical Trend for When the Alarm Occurred.

The operation described here is for the alarm summary.

1. Move the cursor using the up and down arrow keys and select the alarm.

Select the alarm

<016/016>	Channel	Type	Alarm IN Time	Alarm OUT Time
	TI-001	IH	Nov. 16 09:09:41	Nov. 16 09:10:07
	FI-002	IH	Nov. 16 09:09:19	
	FI-001	IR	Nov. 16 09:07:55	Nov. 16 09:08:57
	FI-001	IR	Nov. 16 09:07:53	Nov. 16 09:07:54
	FI-001	IR	Nov. 16 09:07:10	Nov. 16 09:07:11

2. Display the historical trend according to the procedure described in “Changing the Display.”

The data of the following type is displayed.

- When configured to acquire the display data to the internal memory: Display data
- When configured to acquire the event data to the internal memory: Event data

### Alarm ACK Summary

#### Procedure

Date and time when the alarm ACK operation is executed and the name of the user who executed is displayed.

<016/016>	Channel	Type	ACK Time	User Name
	TI-001	IH	Nov. 16 09:09:49	ABC2001
	FI-002	IH	Nov. 16 09:09:23	ABC2001
	FI-001	IR	Nov. 16 09:09:29	ABC2001
	FI-001	IR	Nov. 16 09:09:29	ABC2001
	FI-001	IR	Nov. 16 09:09:29	ABC2001

When alarm ACK operation is executed, the time of execution and the user name are shown on the alarm ACK summary screen.

### Message Summary

#### Procedure

#### Recalling the Historical Trend for When the Message Was Written.

The operation described here is for the memory summary.

1. Move the cursor using the up and down arrow keys and select the message.

Select the message

<003/003>	Message / Time	User Name
	Material1 Nov. 16, 2001 09:10:47	ABC2001
	Batch Start Nov. 16, 2001 09:07:04	ABC2001 [R]
	START Nov. 16, 2001 09:05:20	ABC2001

Operation type (see page 1-14)

2. Display the historical trend according to the procedure described in “Changing the Display.”

The data of the following type is displayed.

- When configured to acquire the display data to the internal memory: Display data
- When configured to acquire the event data to the internal memory: Event data

## Memory Summary

### Procedure

#### Displaying the Historical Trend for the Data Specified by Memory Summary

The operation described here is for the case when the information of display data or event data is displayed in the memory summary.

1. Move the cursor using the up and down arrow keys and select the data.

Select the data →

M. SAMPLE DATA	(02/50)	Nov.16 09:43:15	RELAY 0:■■■■
TLOG DATA	(018/100)	Nov.16 10:20:00	
REPORT DATA	(03/40)	Nov.16 10:00:00	
SAMPLE DATA	: @ DISPLAY DATA		
(04/04)	Batch Name / Start	End Time	Data Status
Process1-00000007	Nov.16 10:24:10	725	Sample
Process1-00000007	Nov.16 09:38:34	Nov.16 10:00:00	644 Auto Save
Process1-00000006	Nov.16 09:27:40	Nov.16 09:30:18	88 Stop
Process1-00000005	Nov.16 09:03:24	Nov.16 09:25:00	649 Stop

2. Display the historical trend according to the procedure described in “Changing the Display.”

## Report Data (/M1 option)

### Procedure

#### Displaying the Report Data

Display the report data according to the procedure described in “Changing the Display.”

Number of the report data being displayed  
 Number of report data stored to the internal memory

Ch	Unit	Sts	Ave	Max	Min	Sum
01	°C	—	105.69	157.06	44.18	1.361338E+05
02	°C	—	32.9	104.3	-52.5	4.233480E+04
03	l/min	—	107.12	171.33	38.21	1.379673E+05
04	m3/h	—	270.3	453.8	58.6	3.481945E+05

#### Switching the Displayed Report Data

The [Number] box of the report data display shows “the number of the report data being displayed/the number of report data saved to the internal memory.” The largest report data number corresponds to the most recent report data.

Press the arrow keys while displaying the report data to switch the report data to be displayed. The behavior when the four keys are pressed is as follows:

**Up arrow key:** Displays the report data corresponding to report data being displayed + 1.

**Down arrow key:** Displays the report data corresponding to report data being displayed - 1.

**Right arrow key:** Displays the report data corresponding to report data being displayed + 10. However, if such report data does not exist, the most recent report data is displayed (maximum report data number).

**Left arrow key:** Displays the report data corresponding to report data being displayed - 10. However, if such report data does not exist, the oldest report data is displayed (report data number 1).

#### Note

Even if a new report data is created while displaying the report data, the display is not updated. The most recent report data is displayed by performing either operation below.

- Press the right arrow key.
- Press DISP/ENTER and display the report data again from the screen menu.

## 7.5 Using the Historical Trend

### Displaying the Historical Trend

There are four methods for displaying the historical trend.

- Display from the alarm summary ⇒ section 7.4
- Display from the message summary ⇒ section 7.4
- Display from the memory summary ⇒ section 7.4
- Call from the screen menu ⇒ section 7.1

### Procedure

#### Changing the Display

1. Press the DISP/ENTER key to display the screen menu.
2. Press the right arrow key to display the sub menu.
3. Select the sub menu item using the up and down arrow keys.

Sub menu of the historical trend screen



- GROUP 1:** Displays group 1
- GROUP 2:** Displays group 2
- GROUP 3:** Displays group 3
- GROUP 4:** Displays group 4
- GROUP 5:** Displays group 5
- GROUP 6:** Displays group 6
- ZOOM+:** Display by expanding the time axis
- ZOOM-:** Display by reducing the time axis
- ALL CHANNEL:**  
Displays the waveform of all the channels (see "Explanation" in section 7.2).
- GROUP CHANNEL:**  
Displays the waveforms of the channels registered to groups.
- MESSAGE DISP 2:**  
Switches to message display 2.
- MESSAGE DISP 1:**  
Switches to message display 1 (see "Explanation" in section 7.2).
- CURSOR TIME ON:**  
Displays the time at the cursor position.
- CURSOR TIME OFF:**  
Displays the time at the display reference position.
- INFORMATION ON:**  
Displays the memory information.

4. Press the DISP/ENTER key to execute the display.  
To close the menu without switching the screen, press the ESC key.

### Reading the Measured/Computed Values Using the Cursor

The measured/computed values at the cursor position are displayed on the screen. You can move the cursor by pressing the left and right arrow keys (during horizontal display) or up and down arrow keys (during vertical display).

- \* When the cursor reaches the end of the displayed waveform, the display range of the waveform moves so that the cursor is at the center of the display range.

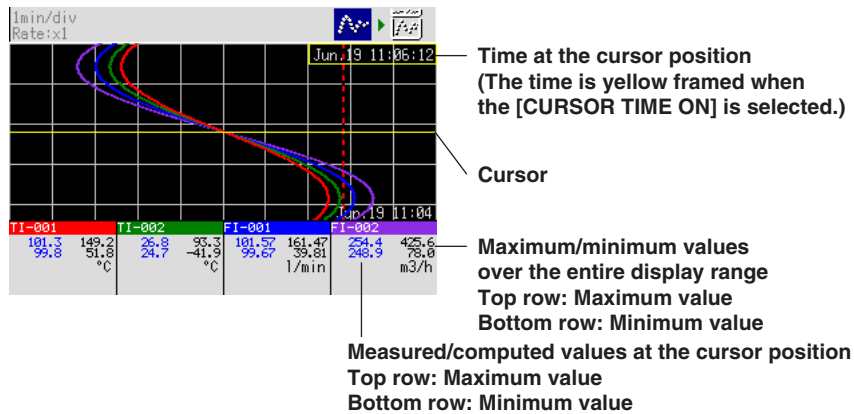

### Note

#### Moving the Cursor

- Press an arrow key once to move the cursor by 1 dot.
- Keep pressing an arrow key to move the cursor by one division. In this case, when the cursor reaches the end of the screen, it no longer moves.

#### Date and Time at the Cursor Position

- Time down to milliseconds is displayed for the following cases. Otherwise, time down to seconds is displayed.
  - Event data acquired at a sampling interval of 500 ms or lower.
  - Display data acquired at a display update rate of 15 sec/div.
- If you reduce the time axis, multiple sampled points exist at each dot on the time axis of the screen. In this case, the time of the oldest data is displayed.

### Scrolling the Waveforms

When the cursor is at the end of the display range and you press the arrow key directed away from the center, the waveform scrolls for a half of page.

## 7.5 Using the Historical Trend

### Specifying the Display Range

The position specified by the frame is the display range. Items inside the parentheses are for vertical trend displays.

1. Press the up (right) arrow key to display the waveform of the entire data range at the top section (right side) of the screen.

#### Display reference position

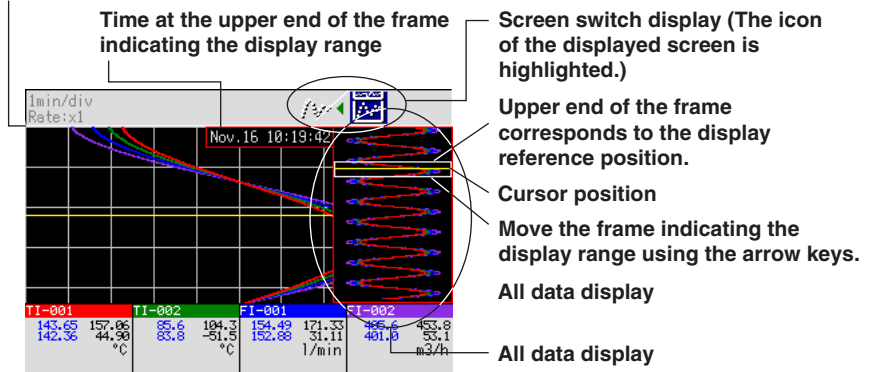

2. Set the display position by moving the frame using the left and right (up and down) arrow keys.
3. Press the down (left) arrow key to display the historical trend with the waveform display position changed.

### Displaying/Clearing the Memory Information

1. Select [INFORMATION ON] according to the procedure described in “Changing the Display” and press the DISP/ENTER key to display the memory information. You can use the left and right arrow keys to switch the memory information display.

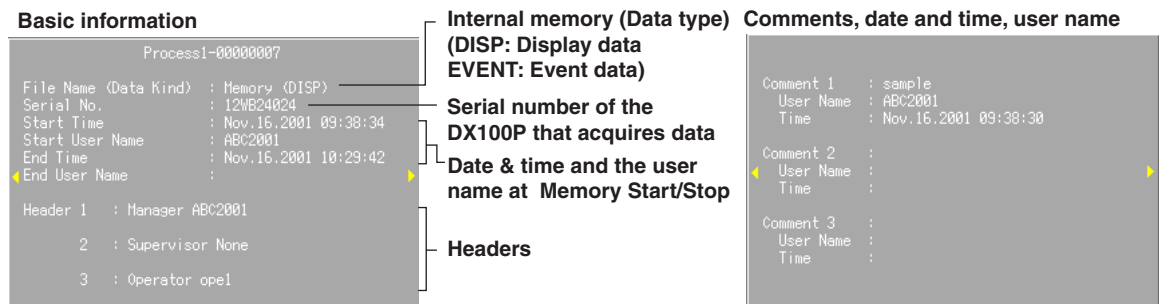

2. Press the DISP/ENTER key to clear the memory information window.

### Expanding/Reducing the Time Axis

Expand or reduce the time axis according to the procedure described in “Changing the Display.” The time axis can be expanded or reduced with respect to the “display reference position.”

**Display data:** 2 times the trend display to 1/60 minimum

**Event data:** Reduction only, up to 1/60 minimum

The minimum magnification and the factor by which the display can be expanded or reduced with one operation vary depending on the display update rate for the display data and on the sampling interval for the event data.

## 8.1 Setting the Batch Number, Lot Number, and Comment

### Procedure

These procedures are carried out in the operation mode.

#### Opening the Batch Screen

1. Press the FUNC key. The soft key menu is displayed.
2. Press the [Batch] soft key to display the batch screen.

The screenshot shows a terminal-style interface with the following text and elements:

- A blue button labeled "Batch" is shown above a grey button.
- The screen displays:
  - Header1: Manager ABC2001
  - 2: Supervisor None
  - 3: Operator ope1
- Below this, there are input fields:
  - Batch No.: A blue cursor is positioned at the end of this field.
  - Lot No.: Contains the digit "0".
  - Comment 1+: A blank line.
  - 2: A blank line.
  - 3: A blank line.
- On the right side of the input fields, there are three horizontal lines with numbers 3, 4, and 5 pointing to the Batch No., Lot No., and Comment 1+ fields respectively.

#### Changing the Batch Number

3. Use the arrow keys to move the cursor (blue) to the [Batch No.] box. Press the [Input] soft key. The other items are dimmed and the batch number can be entered. Change the batch number (up to 32 characters) and press the DISP/ENTER key to confirm the change. For the procedures for entering strings, see section 3.6, "Entering Values and Strings."

#### Changing the Lot Number

4. Use the arrow keys to move the cursor (blue) to the [Lot No.] box. Press the [Input] soft key. The other items are dimmed and the lot number can be entered. Change the lot number (up to 8 digits) and press the DISP/ENTER key to confirm the change. For the procedures for entering values, see section 3.6, "Entering Values and Strings."

#### Note

Batch numbers and lot numbers cannot be changed after Memory Start.

## 8.1 Setting the Batch Number, Lot Number, and Comment

---

### Entering Comments

Three comments (1, 2, and 3) can be set separately.

5. Use the arrow keys to move the cursor to the [Comment] box [1], [2], or [3]. Press the [Input] soft key. The other items are dimmed and the comment can be entered. Enter the comment (up to 32 characters) and press the DISP/ENTER key to confirm the setting.  
For the procedures for entering strings, see section 3.6, "Entering Values and Strings."

### Note

---

- You can change the comment as many times as you wish **before executing Memory Start**. Only the comment that was entered last remains.
  - **After Memory Start**, only the comments that are not specified can be entered. You can change the comment as many times as you wish while the batch screen is displayed. Only the comment that was entered last remains.
  - The comment is cleared when Memory Stop is executed.
- 

### Clearing the Batch Screen Window

Press the DISP/ENTER key or the ESC key while the batch screen is displayed.

### Note

---

The batch number, lot number, and comments are saved to the display data file or event data file. They are not saved to the setup file.

---



## 8.2 Writing Messages Strings (Trend)

You can set arbitrary strings (messages) and display them on the trend display. The displayed message is written to the internal memory.

The written messages can be listed in the message summary. For the procedure in displaying the message summary, see section 7.4.

### Note

Messages can be written after Memory Start.

### Procedure

#### Operation Using the FUNC Key

These procedures are carried out in the operation mode.

1. Press the FUNC key. The soft key menu is displayed.
2. Press the [Message] soft key. Soft keys for free message and message groups 1 through 7 and a message group list window appear.



#### Writing Messages of Message Groups 1 through 7

3. Press one of the [Group 1] to [Group 7] soft keys. Message 1 through 8 soft keys and a message list window appear.

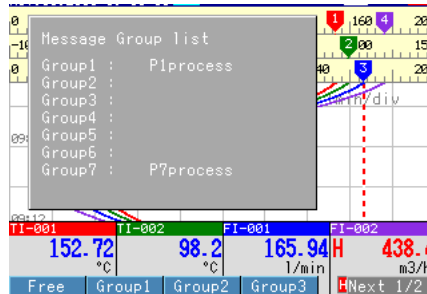

4. Press the soft key corresponding to the message you wish to write. A message mark, time, and the message are displayed on the trend display and written to the internal memory.

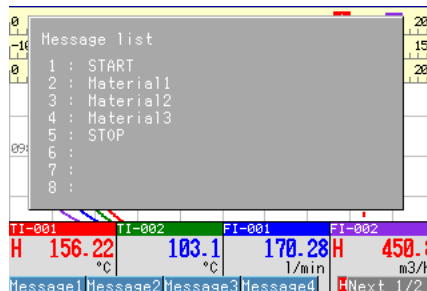

#### Setting and Writing the Message String

3. Press the [Free] soft key. Message 1 through 8 soft keys appear.

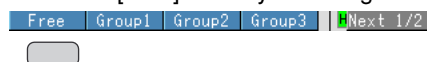

## 8.2 Writing Messages Strings (Trend)

- Press the soft key corresponding to the message you wish to write. A window appears for you to set the message string.

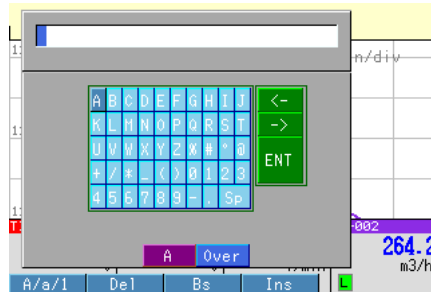

- Enter the message (up to 32 characters), and press the DISP/ENTER key. A message mark, time, and the message are displayed on the trend display and written to the internal memory. A window for entering the message string is cleared.  
For the procedures for entering strings, see section 3.6, "Entering Values and Strings."

### Operation Using the USER Key

The operation described here is for the case when the function used to write the message is assigned to the USER key.

- Press the USER key. A message mark, time, and the message corresponding to the message (1 to 8) that are assigned to the USER key are displayed on the trend display and written to the internal memory.

### Note

Messages that can be written using the USER key are messages 1 to 8 of message group 1 to 7.

### Explanation

#### Message Display Example

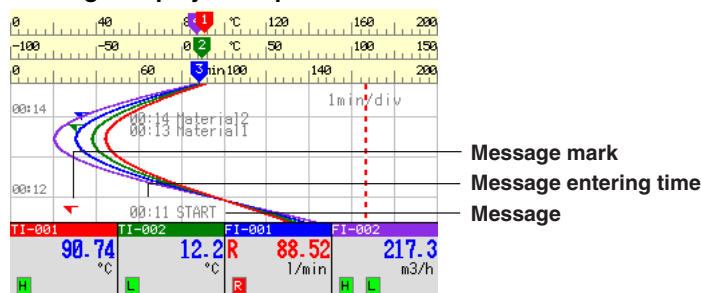

#### Display Color of Message

The message colors on the trend display are shown below. You cannot change the colors.

Message number	1	2	3	4	5	6	7	8
Display color	Red	Green	Blue	Blue-violet	Brown	Orange	Yellow-green	Light blue

## 8.3 Storing Measured/Computed Data at Arbitrary Times (Manual Sampling)

The instantaneous values of the all measurement and computation channels (excluding the measurement channels that are set to [Skip] and the computation channels that are turned Off) can be saved to the external storage medium with a key operation. For actions related to saving manual sampled data, see section 1.4.

The data format of the manual sampled data is explained in appendix 2, "Data Formats of ASCII Files."

### Procedure

#### Operation Using the FUNC Key

This operation is carried out in the operation mode.

1. Press the FUNC key to display the soft key menu.
2. Press the [Manual sample] soft key to execute the manual sampling.



#### Operation Using the USER Key

This is an operation carried out only when the manual sampling is assigned to the USER key.

1. Press the USER key to execute the manual sampling.

---

## 8.4 Starting/Stopping Computation, Resetting Computation, Releasing Computation Dropout Display (/M1 Option)

### Starting/Stopping Computation

#### Procedure

##### Operations Using the START/STOP Key

- **Starting/Stopping the Computation Simultaneously with Memory Start/Stop**

See section 6.2.

- **Stopping the Computation (When Memory Start Is Not Executed)**

1. Press the STOP key. A confirmation window is displayed.

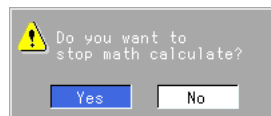

2. Select [Yes] using the arrow keys and press the DISP/ENTER key.

##### Operation Using the FUNC Key

- **Starting the Computation**

1. Press the FUNC key to display the soft key menu.
2. Press the [Math START] key to start the computation. When the computation is started, a computation icon is displayed in the status display section.



- **Stopping the Computation**

1. Press the FUNC key to display the soft key menu.
2. Press the [Math STOP] key to stop the computation. The computation icon in the status display section also disappears.



##### Note

---

When the computation is stopped, the computed data of the computation channel is held at the value that existed immediately before. If data is being acquired to the internal memory, the value held is written.

---

##### Operation Using the USER Key

The operation is for the case when the start/stop function of computation is assigned to the USER key.

- Press the USER key when the computation is stopped to start the computation. When the computation is started, a computation icon is displayed in the status display section.
- Press the USER key when the computation is started to stop the computation. The computation icon in the status display section disappears.

### Resetting the computation

This is executable only when the computation is suspended. Data from all computation channels are cleared.

#### Procedure

##### Operation Using the FUNC Key

1. Pressing the FUNC key displays the soft key menu.  
The [Math reset] soft key is displayed only when the computation is suspended.
2. Pressing the [Math reset] soft key clears the data from all computation channels.



##### Operation Using the USER Key

The operation is for when the reset function of computation is assigned to the USER key. Press the USER key to reset the computation data of all computation channels.

### Clearing the Computation Dropout Display

When a computation data dropout occurs during computation, the computation icon displayed in the status display section turns yellow. The computation icon will return to a white color once the computation data dropout has been acknowledged.

Computation icon



#### Procedure

1. Pressing the FUNC key displays the soft key menu.  
The [Math ACK] soft key is displayed only when a computation data dropout occurs.
2. Pressing the [Math ACK] soft key causes the yellow computation icon in the status display section to return to a white color.

#### Explanation

##### Computation Data Dropout

Computation data dropout occurs when the computation is not completed within the scan interval. When this occurs frequently, lower the CPU load by reducing the number of computation channels or making the scan interval longer. When computation data are acquired to the internal memory, the data immediately before a computation drop out are substituted for the computation data at the time of the dropout.

---

## 8.5 Saving the Screen Image (Snap Shot)

The screen image that is displayed is saved to the external storage medium. The data size of the screen image is approximately 12 KB/screen.

### Procedure

#### FUNC Key Operation

This operation is carried out in the operation mode. The images of soft keys or messages are not saved.

1. Press the FUNC key to display the soft key menu.
2. Press the [Snapshot] soft key. The screen image is saved to the external storage medium. However, the images assigned to soft keys or the message windows are not saved.



#### USER Key Operation

This applies only when [Snapshot] is assigned to the USER key.

This key operates in all run modes (operation, engineering and system modes).

Press the USER key. The exact screen image that is displayed when the USER key is pressed is saved to the external storage medium. However, error messages are not saved.

### Explanation

#### File Format

Screen image data is in "PNG" format.

#### File Name

For details, see appendix 3.

---

## 8.6 Saving the Display Data/Event Data to the External Storage Medium Using Key Operation

This operation saves the display data/event data to the external storage medium at an arbitrary time after Memory Start. For a description on the behavior when this operation is executed, see section 1.4.

**If the type of process is “Batch” (see section 1.4), this operation is not possible. [Save Display] and [Save Event] soft keys do not appear.**

### Procedure

1. Press the FUNC key to display the soft key menu.  
Either the [Save Display] soft key or the [Save Event] soft key is displayed.
2. Press the [Save Display] soft key or the [Save Event] soft key.  
The unsaved data residing in the internal memory is saved to the external storage medium at the time of the next sampling after the soft key is pressed.



[Save Display]: The display data is saved to the external storage medium.

[Save Event]: The event data is saved to the external storage medium.

### Note

---

When the external storage medium does not have enough space, a message “Not enough free space on media” is displayed and the data are not saved to the external storage medium. Change the medium and operate again.

---

## 8.7 Signing Display/Event Data Files on the External Storage Medium

This operation is for loading the display data file or event data file on the external storage medium into the DX100P and signing (adding approval information). Signing is allowed only at the level that has not been signed before (sign 1 to 3).

### Note

- If the type of process is “Batch” and a single batch data is made up of multiple files, you cannot sign the batch data using the DX100P (see page 1-37). Use the DAQSIGNIN that came with the package to sign the data.
- If a single batch data made up of multiple files is combined into a single file using the DAQSIGNIN that came with the package, the DX100P cannot load the file.

### Procedure

1. Press the FUNC key to display the soft key menu.
2. Press the [Load data] soft key to display the display data load or event data load screen.



#### File name and the date & of file creation

Load display data		
Directory	File name	Time
/	Y1609031 DBD	2001/11/16 09:25
DATA6E	Y1609271 DBD	2001/11/16 09:30
DATA00		

Batch Time Details

#### Batch number - lot number

Load display data	
Directory	Batch name-No.
/	Process1-00000005
DATA6E	Process1-00000005
DATA00	

Batch Time Details

### Note

When set to save the display data, the display data load screen is displayed; when set to save the event data, the event data load screen is displayed.

### Switching the File Name Display

3. You can change the file name display using the [Batch] and [Time] soft keys.  
**Batch:** Displays the file name using the batch number and lot number.  
**Time:** Displays the file name in Mddhhmma.DBD (display data file) or Mddhhmma.DBE (event data file) format and displays the time the file was created. For details on Mddhhmma, see appendix 3.



**Selecting the File**

4. The directories in the external storage medium are displayed in the [Directory name] column. Press the up or down arrow key to select the directory containing the display/event data to be loaded. A list of files in the selected directory is displayed in the right column.
5. Press the right arrow key to move the cursor on to the file list. Press the up or down arrow key to select the file to be loaded. To cancel the operation, press the ESC key.

**Confirming the File Information**

6. Press the [Details] soft key to view the information about the file.

<pre> File name   : Y1609031.DBD Damage check : Not damaged Batch name  : _____ Process1-00000005 Settings file number :3 Signature1:(Not signed in yet.) Signature2:(Not signed in yet.) Signature3:(Not signed in yet.)                 </pre>	<ul style="list-style-type: none"> <li>— File name*</li> <li>— Damage check</li> <li>— Damaged: File damaged, data tampered, etc.</li> <li>— Batch name</li> <li>— Batch number - Lot number</li> <li>— Setting file number</li> <li>— Sequence number of the setup file used</li> <li>— Sign record</li> </ul>
--	---

\* For data that is saved using keys while data acquisition is stopped, the file name appears in red. See page 1-30.

7. Press the DISP/ENTER key or the ESC key to clear the file information window.

**Displaying the Data**

8. Press the DISP/ENTER key to display the selected file in the signing record display.

**Signing**

For the signing procedure, see section 6.3.

# 8.8 Displaying the List of Files and the Free Space on the External Storage Medium

## Procedure

- 1. Pressing the FUNC key displays the soft key menu.
- 2. Pressing the [File list] soft key displays the [File list] screen. The directories in the external storage medium are displayed. [/] is the root directory.



- 3. Using the arrow keys select the directory. Files in the directory are listed to the right.

File list			
Directory	File name	Time	
/	SET1P2 PPL	2001/11/11 20:36	
DATA6E	SET2P2 PPL	2001/11/11 20:59	
SET0	SET3P2 PPL	2001/11/11 21:07	
DATA7E			
Free space 1235 Kbytes			

File list

- 4. Pressing the right arrow key moves the cursor to the file list. The list can be scrolled using the arrow keys. To move back to the [Directory name] column, press the left arrow key.
- 5. Press the ESC key to return to the [Save/Load] menu screen.

## 8.9 Displaying the Log Screen/System Screen

### Procedure

#### Display the Log Screen/System Screen

1. Press the FUNC key to display the soft key menu.
2. Press the [Log] soft key. The types of logs that can be displayed and the system screen are assigned to the soft keys and displayed.



3. Press a soft key to display the log or the system screen.

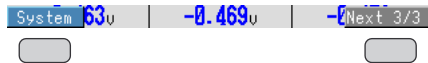
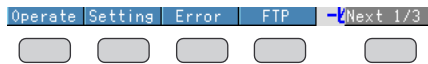

**[Operate] soft key:** Displays a log of operations.

**[Change] soft key:** Displays a log of setting changes.

**[Error] soft key:** Displays a log of error messages.

**[FTP] soft key:** Displays a log of file transfers made using the FTP client function.

**[Commu] soft key:** Displays a log of communication commands that have been executed.

**[E-Mail] soft key:** Displays a log of e-mail transmission.

**[Web] soft key:** Displays a log of operations on the Web screen (when the web server function is in use).

**[SNTP] soft key:** Displays the Access Log of the SNTP Server

**[System] soft key:** Displays the system screen.

#### Displaying the Details of the Operation Log

If you press the ESC key while displaying the operation log, the details of the log are displayed as follows:

- Log of calibration correction setting changes during data acquisition
- Log of the starting of the gradual time correction
- Log accompanying erroneous operation and warning messages

If you press the ESC key again, the screen returns to the operation log.

#### Scrolling through the log

Use the up and down arrow keys to scroll through the log.

#### Returning to the Operation Screen

To return to the operation screen from the log screen or the system screen, press the DISP/ENTER key to display the screen menu, select the desired screen using the up and down arrow keys, and then press the DISP/ENTER key.

**Explanation**

**Operation Log**

For the detail of operation logs, see appendix 5.

The number of the log displayed on the last line

Total number of logs

(0012/0065)	Time	Action	User Name	ESC
Jun.03	11:02:49	Logout	ABC2001	
Jun.03	11:02:41	TRevEnd	ABC2001	[Y]
Jun.03	10:53:37	TRevStart	ABC2001	
Jun.03	10:53:37	TimeChg	ABC2001	
Jun.03	10:53:05	Error158	ABC2001	
Jun.03	10:53:05	TimeChg	ABC2001	
Jun.03	10:51:36	CCSet06	ABC2001	

Operation type (see page 1-35)

Name of the user who performed the operation

Operation information

Date and time when operation was performed

↓ ESC key ↑

**Detailed display**

(0031/0083)	Details	ESC
TRevStart	Adjust time = -00:08.500.000	
Error158	Exceeds time deviation setting.	
CCSet06	04: 2.000/ 1.999 ➔ 2.000/ 1.998	

**Setting Change Log**

The number of the log displayed on the last line

Total number of logs

(012/016)	Time	File Name	User Name
Nov.19	10:49:25	Y1910491	ABC2001
Nov.19	10:25:03	Y1910251	ABC2001
Nov.19	10:12:33	Y1910121	ABC2001
Nov.19	07:04:44	Y1907041	ABC2001
Nov.19	07:01:39	Y1907011	ABC2001
Nov.19	06:55:06	Y1906551	ABC2001
Nov.16	14:44:27	Y1614441	ABC2001
Nov.16	14:35:07	Y1614351	ABC2001
Nov.16	14:28:00	Y1614281	ABC2001
Nov.16	13:16:04	Y1613161	ABC2001
Nov.16	12:36:56	Y1612361	ABC2001
Nov.16	12:33:35	Y1612331	ABC2001

Name of the user who changed the settings

Setup file name that was saved

Date and time when settings were changed

**Error Message Log**

The number of the log displayed on the last line

Total number of logs

(012/050)	Time	No.	Message
Nov.19.2001	10:50:18	111	The login user ID is inc..
Nov.19.2001	10:48:08	612	Please acknowledge all a..
Nov.19.2001	10:13:30	089	Press [FUNC] key to logi..
Nov.19.2001	10:13:02	601	Measured data have been ..
Nov.19.2001	10:12:30	613	You can't sign this reco..
Nov.19.2001	07:15:51	245	This function cannot be ..
Nov.19.2001	07:15:05	152	This action is not possi..
Nov.19.2001	07:14:50	210	Media has not been inser..
Nov.19.2001	07:08:46	152	This action is not possi..
Nov.19.2001	07:08:46	152	This action is not possi..
Nov.19.2001	07:07:50	612	Please acknowledge all a..
Nov.19.2001	07:07:46	612	Please acknowledge all a..

Error message

Error code (see chapter 9)

Date and time of occurrence

**FTP Log**

The number of the log displayed on the last line  
Total number of logs

(002/002)	Time	No.	Code	Flag	File Name
Jan.31.2001	06:58:08	282	HOSTNAME	S	13106580.DHR
Jan.31.2001	06:58:08	282	HOSTNAME	P	13106580.DHR

Date and time when the file transfer was made  
Error code (see chapter 9)  
FTP server (P: primary, S: secondary)  
File name

**Communication Command Log**

The number of the log displayed on the last line  
Total number of logs

(000/000)	Time	ID	I/O	Message	Link
Jan.31.2001	07:23:33	1	<	(Logout)	
Jan.31.2001	07:23:23	1	>	cc 0	

Date and time when the access occurred  
Message  
I/O symbol (>: input, <: output)  
A number used to identify the user that is connected  
Ethernet interface  
Green: Electrically connected  
Gray: Not connected

**E-mail Log**

The number of the log displayed on the last line  
Total number of logs

(004/004)	Time	Type	No.	Recipient / Error
Jan.31	06:16:49	Alarm	264	1 Some recipients' a..
Jan.31	06:16:19	Alarm		1 H,S
Jan.31	06:16:17	Fail		1+2 H,S uu
Jan.31	06:15:53	Alarm		1 H,S

Date/time Mail type  
Recipient address  
Recipient No.  
Error code (see chapter 9)

**Web Browser Operation Log**

The number of the log displayed on the last line  
Total number of logs

(003/003)	Time	Request	No.	Parameter
Jan.31	06:52:38	Key		DOWN
Jan.31	06:51:21	Screen		TREND GROUP=2

Date/time Type Error code (see chapter 9 when a code is displayed)  
Operation

**SNTP Log**

For the detailed code, see chapter 6 in the Communication Interface User's Manual (IM 04L05A01-17E).

The number of the log displayed on the last line  
Total number of logs

(005/005)	Time	No.	Code
Jun.08.2004	00:50:13		SUCCESS
Jun.08.2004	00:50:00	294	OVER
Jan.04.2000	18:32:26	290	LINK
Jan.04.2000	18:31:49	292	HOSTNAME
Jan.04.2000	18:30:34	291	TIMEOUT

Date and time of access to the SNTP server  
Detailed code  
Error code (see chapter 9)

**System Screen**

See "System Screen" in section 1.10.

## 8.10 Changing the Password

This operation is for changing the password that is used when logging in.

Procedure

1. Press the FUNC key. The soft key menu is displayed.
2. Press the [Password change] soft key. A window appears for you to enter the password currently in use.



3. Enter the password in use and press the DISP/ENTER key. A window appears for you to enter the new password. For the procedures for entering strings, see section 3.6, "Entering Values and Strings."

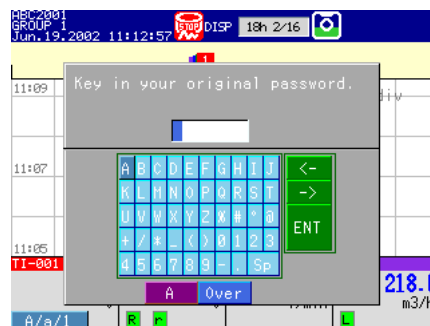

4. Enter the new password (6 to 8 alphanumeric characters, spaces are not allowed) and press the DISP/ENTER key. A window appears for you to enter the password again. Enter the same password.

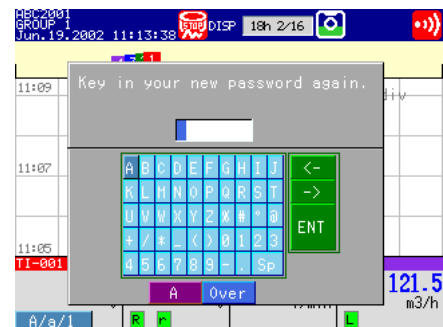
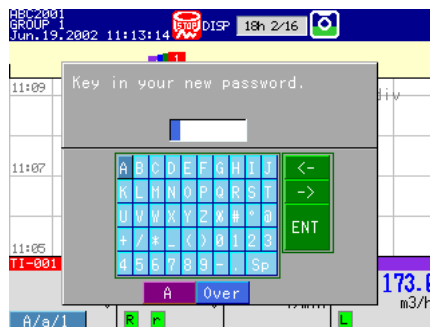

### Note

- When the use of the user ID is enabled, the combination of the user ID and password must be unique.
- When entering the password currently in use, if you repeat the operation of entering a wrong password and pressing the DISP/ENTER key **three times**, the user is invalidated. Have the administrator set a default password and reset the password according to "Logging in for the First Time" (see section 6.1).

## 8.11 Acknowledging Alarms (Alarm ACK)

Alarm ACK is an operation used to acknowledge the activated alarm when the alarm display and alarm output relay behavior is set to [Hold].

### Procedure

#### Alarm ACK against Individual Alarms

This operation is carried out on the overview screen. For the operating procedure, see section 7.3.

#### Alarm ACK against All Alarms Occurring

You can acknowledge all alarms occurring or have occurred but not yet acknowledged at once .

- When you assign [Alarm ACK] to the USER key and execute the alarm ACK.
- When you execute the alarm ACK via the remote control function (/R1 option).

### Explanation

#### Alarm Indication

The alarm condition can be confirmed with the alarm icon in the status display section and the alarm indication on the operation screen such as the trend screen. The indicator pattern varies depending on the hold/non-hold setting (see section 1.6). For an example, the alarm icon on the status display section is explained below.

- **The Alarm Icon in the Status Display Section**

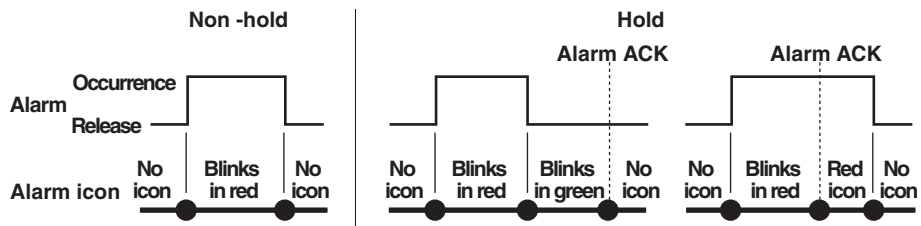

#### Alarm Output Relay

For the description, see “Hold/Non-Hold Operation of the Alarm Output Relay ” in section 1.6.

#### Note

##### If the same alarm occurs before performing the alarm ACK operation

The same alarm is acknowledged through a single alarm ACK operation.

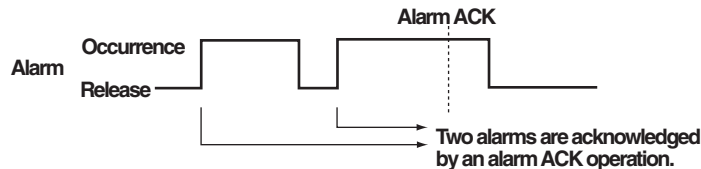

Alarm information of each alarm is recorded in the alarm summary.

---

## 8.12 Clearing the User Locked Icon

Clears the user locked icon (  ) on the status display section.  
You can clear the icon when you are logged in as a registered administrator.

### Procedure

1. Press the FUNC key to display the soft key menu.
2. Press the [Locked ACK] soft key. The user locked icon is cleared.





## 9.1 A List of Messages

Occasionally, error codes and messages appear on the screen while using the DX100P.  
The entire list of messages is given below.

The messages are displayed in the language that you have chosen.

### Errors Related to Parameter Settings

#### • Setting Errors

Code	Message	Explanation/Countermeasures/Ref. section
1	System error.	Contact your nearest YOKOGAWA dealer.
2	Incorrect date or time setting.	See section 5.15.
3	A disabled channel is selected.	See section 5.3 (Communication Interface Manual).
4	Incorrect function parameter.	See section 5.3 (Communication Interface Manual).
5	The input numerical value exceeds the set range.	Enter a proper value.
6	Incorrect input character string.	Enter a proper character string.
7	Too many characters.	Enter specified number of characters.
8	Incorrect input mode.	See section 5.1.
9	Incorrect input range code.	See section 5.1.
21	Cannot set an alarm for a skipped channel.	See section 5.1.
22	The upper and lower span limits are equal.	See section 5.1.
23	The upper and lower scale limits are equal.	See section 5.1.
30	The partial boundary value exceeds the range of the span.	See section 5.11.
31	Partial expansion display is set ON for a SKIPPED channel.	See section 5.1.
35	The upper and lower limits of the display band are equal.	See section 5.11.
36	The lower limit of the display band is greater than the upper limit.	See section 5.11.
37	The display band is narrower than 4% of the entire display.	See section 5.11.
40	Incorrect group set character string.	See section 5.9.
41	There is no specified input channel.	Check the number of input channels.
42	Exceeded the number of channels which can be set.	Check the number of input channels.
43	A channel number cannot repeat in a group.	See section 5.9.
45	There is no character string saved in the clipboard.	Copy a character string to the clipboard.
46	The character string saved in the clipboard is too long.	Paste a character string with the specified number of characters.
61	There is no channel specified by the MATH expression.	See section 5.18.
62	MATH expression grammar is incorrect.	See section 5.18.
63	MATH expression sequence is incorrect.	See section 5.18.
64	MATH upper and lower span values are equal.	See section 5.18.
70	MATH constant description is incorrect.	See section 5.18.
71	The range of the MATH constant is exceeded.	See section 5.18.
80	This username is already registered.	See section 4.4.
81	All space or 'quit' string cannot be specified.	See section 4.4.
83	Duplicate used combination of user ID and password.	See section 4.4.
85	The login password is incorrect.	See section 6.1.
86	The key-lock release password is incorrect.	-
87	This key is locked.	See section 4.4.
88	This function is locked.	See section 4.4.
89	Press [FUNC] key to login.	See section 6.1.
90	No permission to enter to the SETUP mode.	-
91	Password is incorrect.	Enter correct password. See sections 6.1 and 6.3.

## 9.1 A List of Messages

Code	Message	Explanation/Countermeasures/Ref. section
92	Press [ESC] key to change to the operation mode.	Press the ESC key.
93	String including space or all space cannot be specified.	Spaces are not allowed in the Web user name and password.
94	More than one address cannot be specified.	Multiple addresses cannot be specified. Only a single sender is allowed.
95	This function is locked.	Unlock the function. See section 4.4.
100	IP address doesn't belong to class A, B, or C.	See section 2.3 (Communication Interface Manual).
101	The result of the masked IP address is all 0s or 1s.	See section 2.3 (Communication Interface Manual).
102	SUBNET mask is incorrect.	See section 2.3 (Communication Interface Manual).
103	The net part of default gateway is not equal to that of IP address.	See section 2.3 (Communication Interface Manual).
110	This user name is not registered.	Enter a registered user name. See sections 4.4 and 6.1.
111	The login user ID is incorrect.	Enter the correct user ID. See sections 4.4, 6.1, and 6.3.
112	Password must use more than 6 alphanumeric characters.	A space or spaces cannot be used. See section 6.1.
113	Password entered is incorrect.	Enter the correct password. See sections 6.1 and 8.10.
114	This user name is invalid.	Use a valid user name.
115	Relay behavior Hold and Indicator Nonhold can not be selected.	See section 4.1.
116	This user name cannot be specified.	See section 4.4.
117	This password is not effective.	See section 6.1.
118	You are logged out, because of invalid access.	Register the user again. See section 4.4.
119	This user name is unable to use this mode.	Use other user name to log in. See section 4.4.
120	Measured value is incorrect. (in ascending order)	See section 5.21.
121	A user is already logged in.	See section 1.5.
122	Measured value exceeds the range setting.	See section 5.21.
123	Measure function cannot be used until range settings are stored.	See section 5.21.
124	Password entry cannot be performed.	Errors when entering characters using barcode. See section 3.7 of IM04L05A01-17E.
125	Character entry cannot be performed.	Errors when entering characters using barcode. See section 3.7 of IM04L05A01-17E.

### • Execution Errors

Code	Message	Explanation/Countermeasures/Ref. section
150	This action is not possible because sampling is in progress.	Execute Memory Stop if the action is necessary.
151	This action is not possible during sampling or calculating.	Execute Memory Stop or stop computation if the action is necessary.
152	This action is not possible because saving is in progress.	Wait till the saving ends.
153	This action is not possible because formatting is in progress.	-
155	The message is not written while sampling is stopped.	Messages can be written after Memory Start.
157	This function is not possible at this time.	-
158	Exceeds time deviation setting.	Set a time within the deviation time. See section 4.15.
170	End process can't proceed, because setting file is not saved to Media.	Check the external storage medium. See section 3.5.
171	The selected configuration file is not compatible with this system.	Select other configuration file.
172	Data save is not possible in the current operating mode.	Save engineering mode settings first. See section 5.24.
173	Data save is not possible because of insufficient media capacity.	Use another storage medium. See section 5.24.

## Operation Errors

### • Errors Related to External Storage Medium

Code	Message	Explanation/Countermeasures/Ref. section
200	Operation aborted because an error was found on media.	Check the storage medium.
201	Not enough free space on media.	Use another storage medium.
202	Media is read-only.	Release the write protection.
210	Media has not been inserted.	Insert a storage medium into the drive.
211	Media is damaged or not formatted.	Use another storage medium or carry out formatting.
212	Format error.	Try formatting again or use another storage medium.
213	The file is read-only.	Access to other files or make the file write-enable.
214	There is no file or directory.	See section 5.3 (Communication Interface Manual).
215	Exceeded the allowable number of files.	Delete files or change storage medium.
216	The file or directory name is incorrect.	See sections 4.11, 4.12, 5.7, and 5.23.
217	Unknown file type.	Access to other files.
218	Directory exists. Delete the directory or change directory name.	See section 5.7.
219	Invalid file or directory operation.	Cannot handle files and directories in the 2nd and deeper layers.
220	The file is already in use. Try again later.	Wait till file is free.
230	There is no setting file.	Access to other files.
231	Abnormal setting exists in file.	Access to other files.

### • Errors Related to Historical Trend

Code	Message	Explanation/Countermeasures/Ref. section
232	There is no available data.	This message may appear when recalling historical trend. Access to other files.
233	The specified historical data do not exist.	This message may appear when recalling historical trend.
234	The specified channel is not assigned to the display group.	This message may appear when switching to trend or bar graph from overview. See section 5.9.

### • Errors Related to Sign Record

Code	Message	Explanation/Countermeasures/Ref. section
240	You cannot sign this record because a signature is already present.	Sign at the same authority level is allowed once.
243	This file is not allowed to sign record.	Only files created at Memory Stop can be signed.
244	Data is damaged or changed.	You cannot sign this file.
245	This function cannot be used in the record signature display.	Exit from the sign record screen. See section 6.3.
246	This function cannot be used due to no data file saved in media.	Insert a storage medium. If a storage medium is already present, replace with a formatted medium.
247	This function cannot be used in the engineering mode display.	End the engineering mode. See section 3.5.
248	Signature function cannot be performed.	Insert a normal storage medium containing the data to be signed.

## 9.1 A List of Messages

---

### • Errors Related to E-mail and Web Server

Code	Message	Explanation/Countermeasures/Ref. section
260	IP address is not set or ethernet function is not available.	The IP address is not specified. Check the IP address.
261	SMTP server is not found.	Occurs when the SMTP server is specified. <ul style="list-style-type: none"><li>• Check the DNS setting.</li><li>• Check the SMTP server name.</li></ul>
262	Cannot initiate E-mail transmission.	<ul style="list-style-type: none"><li>• The host name of the DX is not correct. Check the host name.</li><li>• The port number for SMTP server is not correct. Check the port number.</li></ul>
263	Sender's address rejected by the server.	Check the sender's address.
264	Some recipients' addresses are invalid.	Check the recipient's address.
265	SMTP protocol error.	May occur if a network failure (cable problems, duplicate addresses, network device failure, and so on) occurs in the middle of the e-mail transmission.
266	Ethernet cable is not connected.	Check the cable connection.
267	Could not connect to SMTP server.	<ul style="list-style-type: none"><li>• Check to see that the SMTP server is connected to the network.</li><li>• If the SMTP server name is specified using an IP address, check to see that the IP address is correct.</li></ul>
268	E-mail transmission request failed.	Contact your nearest YOKOGAWA dealer.
269	E-mail transfer error.	May occur if a network failure (cable problems, duplicate addresses, network device failure, and so on) occurs in the middle of the e-mail transmission.
275	The current image cannot be output to the Web.	The setup screen cannot be output to the Web browser. This message is displayed on the Web browser.
276	Image data currently being created. Unable to perform key operation.	Try again a little later. This message is displayed on the Web browser.
277	Could not output screen to Web.	Failed to create the image. This message is displayed on the Web browser.
278	Web control denied because a user has control.	If there is a user logged in using the keys on the DXP or if there is a user logged into the setting function of the setting/measurement server of the DXP via the communication interface, you cannot operate the DXP from the browser.

### • Errors Related to FTP Client

For information regarding the FTP client function of the DX100P, see the DX100P/ DX200P Communication Interface User's Manual (IM 04L05A01-17E).

Code	Message
280	<p>IP address is not set or FTP function is not available. Further details are provided by the character string that appears after error code 280.</p> <hr/> <p><b>Character String and Details</b></p> <hr/> <p>HOSTADDR The DX's IP address has not been specified. Check the IP address.*<sup>1</sup></p> <p>DORMANT Internal processing error.*<sup>2</sup></p> <p>LINK Data link is disconnected. Check the cable connection.</p>
281	<p>FTP mail box operation error. Further details are provided by the character string that appears after error code 281.</p> <hr/> <p><b>Character String and Details</b></p> <hr/> <p>MAIL Internal processing error.*<sup>2</sup></p> <p>STATUS Internal processing error.*<sup>2</sup></p> <p>TIMEOUT Internal processing error.*<sup>2</sup></p> <p>PRIORITY Internal processing error.*<sup>2</sup></p> <p>NVRAM Internal processing error.*<sup>2</sup></p>
282	<p>FTP control connection error. Further details are provided by the character string that appears after error code 282.</p> <hr/> <p><b>Character String and Details</b></p> <hr/> <p>HOSTNAME Failed the DNS lookup (search the IP address corresponding to the host name). Check the DNS setting and the destination host name.</p> <p>TCPIP Internal processing error.*<sup>2</sup></p> <p>UNREACH Failed to connect to a control connection server. Check the address setting and that the server is running.</p> <p>OOBINLINE Internal processing error.*<sup>2</sup></p> <p>NAME Internal processing error.*<sup>2</sup></p> <p>CTRL The control connection does not exist. Check that the server does not drop the connection and that it responds within the proper time period.</p> <p>IAC Failed to respond in the TELNET sequence. Check that the server does not drop the connection and that it responds within the proper time period.</p> <p>ECHO Failed to transmit data on the control connection. Check that the server does not drop the connection and that it responds within the proper time period.</p> <p>REPLY Failed to receive data on the control connection. Check that the server does not drop the connection and that it responds within the proper time period.</p> <p>SERVER The server is not in a condition to provide the service. Check that the server is in a condition in which service can be provided.</p>

## 9.1 A List of Messages

---

Code	Message
283	<p>FTP command was not accepted.</p> <p>Further details are provided by the character string that appears after error code 283.</p> <hr/> <p><b>Character String and Details</b></p> <hr/> <p>USER Failed user name verification. Check the user name setting.*<sup>1</sup></p> <p>PASS Failed password verification Check the password setting.*<sup>1</sup></p> <p>ACCT Failed account verification. Check the account setting.*<sup>1</sup></p> <p>TYPE Failed to change the transfer type. Check that the server supports the binary transfer mode.</p> <p>CWD Failed to change the directory. Check the initial path setting.*<sup>1</sup></p> <p>PORT Failed to set the transfer connection. Check that the security function is disabled.</p> <p>PASV Failed to set the transfer connection. Check that the server supports PASV commands.</p> <p>SCAN Failed to read the transfer connection settings. Check that proper response to the PASV command is received from the server.</p>
284	<p>FTP transfer setting error.</p> <p>Further details are provided by the character string that appears after error code 284.</p> <hr/> <p><b>Character String and Details</b></p> <hr/> <p>MODE Internal processing error.*<sup>2</sup></p> <p>LOCAL Internal processing error.*<sup>2</sup></p> <p>REMOTE The destination file name is not correct. Check that you have the authority to create or overwrite files.</p> <p>ABORT File transfer abort was requested by the server. Check the server for the reason for the abort request.</p>

\*1 See the DX100P/DX200P Communication Interface User's Manual (IM 04L05A01-17E).

\*2 Contact your nearest YOKOGAWA dealer when the messages is displayed.

---

**Code Message**

---

285 FTP data connection error.

Further details are provided by the character string that appears after error code 285.

---

**Character String and Details**

---

## SOCKET

Failed to create a socket for the transfer connection.\*3

## BIND

Failed the transfer connection command.\*3

## CONNECT

Failed the transfer connection.\*3

## LISTEN

Failed the transfer connection reception.\*3

## ACCEPT

Failed to accept the transfer connection.\*3

## SOCKNAME

Internal processing error.\*2

## RECV

Failed to receive data over the transfer connection.\*3

## SEND

Failed to send data over the transfer connection.\*3

---

287 FTP is failed because of file acquirement from external media.

---

\*2 Contact your nearest YOKOGAWA dealer when the messages is displayed.

\*3 These errors may occur if the network experiences trouble during the data transmission (bad cable connection, duplicate addresses, network equipment failure).

---

**Note**

---

For information regarding the FTP client function of the DX100P, see the DX100P/DX200P Communication Interface User's Manual (IM 04L05A01-17E).

## 9.1 A List of Messages

---

### Errors Related to SNTP Client

---

290	SNTP access failure	Further details are provided by the character string that appears after error code 290.
<hr/>		
<b>Character String and Details</b>		
<hr/>		
DORMANT Internal processing error.*1		
LINK The link is dropped. Check the cable connection.		
<hr/>		
291	SNTP server does not respond.	Further details are provided by the character string that appears after error code 291.
<hr/>		
<b>Character String and Details</b>		
<hr/>		
TIMEOUT Confirm the SNTP server is in service.*2		
<hr/>		
292	Incorrect SNTP server setting.	Further details are provided by the character string that appears after error code 292.
<hr/>		
<b>Character String and Details</b>		
<hr/>		
HOSTNAME Failed to specify the IP address from a hostname using the DNS. Check the settings for DNS and the name of the SNTP server.		
TCPIP Internal processing error.*1		
<hr/>		
293	Invalid SNTP server reply.	Further details are provided by the character string that appears after error code 293.
<hr/>		
<b>Character String and Details</b>		
<hr/>		
SEND The DXP's IP address has not been specified correctly. Check the IP address.		
BROKEN Access to the SNTP server manually several times. If this error occurs check the SNTP server.		
<hr/>		
294	No time correction because excess time deviation with SNTP server.	Further details are provided by the character string that appears after error code 294.
<hr/>		
<b>Character String and Details</b>		
<hr/>		
OVER This error occurs when a periodic time adjustment does not operate because the time deviation between the time of the DXP internal clock and the SNTP server exceeds ten minutes. Check the time on the SNTP server.		

\*1 Contact your nearest YOKOGAWA dealer.

\*2 These errors may occur if the network experiences trouble during the data transmission (bad cable connection, duplicate addresses, network equipment failure).



## Communication Errors

An English error message is returned via the communication interface. It is not displayed on the screen.

For information regarding the communication function of the DX100P, see the DX100P/DX200P Communication Interface User's Manual (IM 04L05A01-17E).

- **Errors Related to Engineering Mode Setting, System Mode Setting, Control, and Output Command Execution**

Code	Message
300	Command is too long.
301	Too many number of commands delimited with ';'.
302	This command has not been defined.
303	Data request command can not be enumerated with sub-delimiter.
350	Command is not permitted to the current user level.
351	This command cannot be specified in the current mode.
352	The option is not installed.
353	This command cannot be specified in the current setting.
354	This command is not available during sampling or calculating.
360	Output interface must be chosen from Ethernet or Serial.
362	There are no data to send 'NEXT' or 'RESEND'.
363	All data have already been transferred.
367	Password change denied because another user is logged in.

## 9.1 A List of Messages

---

- **Maintenance and Test Communication Command Errors**

An English error message is returned via the communication interface. It is not displayed on the screen.

Code	Message
390	Command error.
391	Delimiter error.
392	Parameter error.
393	No permission.
394	No such connection.
395	Use 'quit' to close this connection.
396	Failed to disconnect.
397	No TCP control block.

- **Other Communication Errors**

An English error message is returned via the communication interface. Codes other than 085 and 117 are not displayed on the DX100P/DX200P screen.

Code	Message and Description
085	The login password is incorrect. The password is incorrect. Check the password.
117	This password is not effective. The user is invalidated. If the login operation is carried out with a wrong password for three consecutive times, the user is invalidated. From that point, the user can no longer log in. Clearing the user locked condition Administrators can clear the user locked condition. For the procedure, see section 6.1.
400	Input username. Enter a user name that is registered in the DXP.
401	Input password. Enter the password.
402	Select function from 'setting' or 'monitor'. Specify the function to be connected, "setting" or "monitor".
403	Login incorrect, try again! Login failed. Restart from the user name.
404	No more login at the specified level is acceptable. Attempting to connect exceeding the number of simultaneous connections allowed (setting function: 1, monitor function: up to 2). Connect to a different function or use "quit" to exit.
405	Input user ID. Input user ID.
407	Password has expired. Please enter a new password. The password is expired. Enter a new password.
408	Enter password again for confirmation. Reenter the password for confirmation.
409	This password is not correct or was already used. The password is incorrect. Or, the password has been used in the past. The combinations of user IDs and passwords that are identical to those specified by other users or those that have been registered in the past cannot be specified. Enter the password using 6 to 8 alphanumeric characters. Spaces cannot be used for the password.
420	Connection has been lost. The specified function name (setting or monitor) is incorrect. Or, "quit" was used for the user name. Communication has been disconnected. Enter the correct function name using lowercase letters. You cannot use "quit" as a user name.

Code	Message and Description
421	The number of simultaneous connection has been exceeded. Attempted to connect exceeding the maximum number of simultaneous connections. Drop other connections first.
422	Communication has timed-out. Connection has been dropped due to communication timeout. Enter the function name, user name, user ID, and password within two minutes.
450	This entry is incorrect. User information is incorrect. Communication has been disconnected. Check the user name, user ID, and password.
451	Login prohibited because another user is logged in. There is a user with the same user name already logged into the setting/measurement server, maintenance/test server, or FTP server. Or, there is a user logged in using keys on the DXP (administrator or user) when attempting to log into the setting function of the setting/measurement server. Check the login status.

### Status Messages

Code	Message
500	Execution is complete.
501	Please wait a moment...
503	Data are being saved to media...
504	File is being loaded from media...
505	Formatting...
506	Memory save to media was interrupted.
507	Exchange media to continue the saving operation.
508	There is no file or directory.
510	Range cannot be changed during sampling or calculating.
511	MATH expression cannot be changed during sampling or calculating.
512	Because memory save is 'manual' mode, FTP is not available.
513	Cannot change during calculating.
520	Connecting to the line...
521	The data file is being transferred.
551	FTP test is being executed...
553	Review and sign functions cannot be used when the file is divided.
554	Signature functions are being executed.
555	Login prohibited because software login is active.
556	Press [FUNC] key to login.
557	This user is not allowed to change a setting.
558	Setting changes are aborted while data is saved.
559	This command must be used with LL command.
560	Now connecting to SNTP server...
561	Now adjusting the time.

## 9.2 Troubleshooting Flow Chart

---

### Cautions

Code	Message	Ref. section
600	Measured data and Settings have been initialized.	See section 4.13.
601	Measured data have been initialized.	See sections 4.13 and 3.5.
610	This user name is already registered.	See section 4.4.
611	There is no user who can enter to the SETUP mode.	–
612	Please acknowledge all active alarms before stopping this record.	See section 8.11.
613	You can't sign this record because of being made by memory time up.	See sections 1.4 and 1.5.
614	Calibration settings are reset because of range setting change.	See sections 5.21.
615	Setting changes are aborted while data is saved.	See section 3.4.

### System Errors

Servicing is required when a system error occurs. Contact your nearest YOKOGAWA dealer for repairs.

Code	Message
901	ROM failure.
902	RAM failure.
910	A/D memory failure for all input channels.
911	Channel 1 A/D memory failure.
912	Channel 2 A/D memory failure.
913	Channel 3 A/D memory failure.
914	Channel 4 A/D memory failure.
921	Channel 1 A/D calibration value error.
922	Channel 2 A/D calibration value error.
923	Channel 3 A/D calibration value error.
924	Channel 4 A/D calibration value error.
930	Memory acquisition failure.
940	The Ethernet module is down.

## 9.2 Troubleshooting Flow Chart

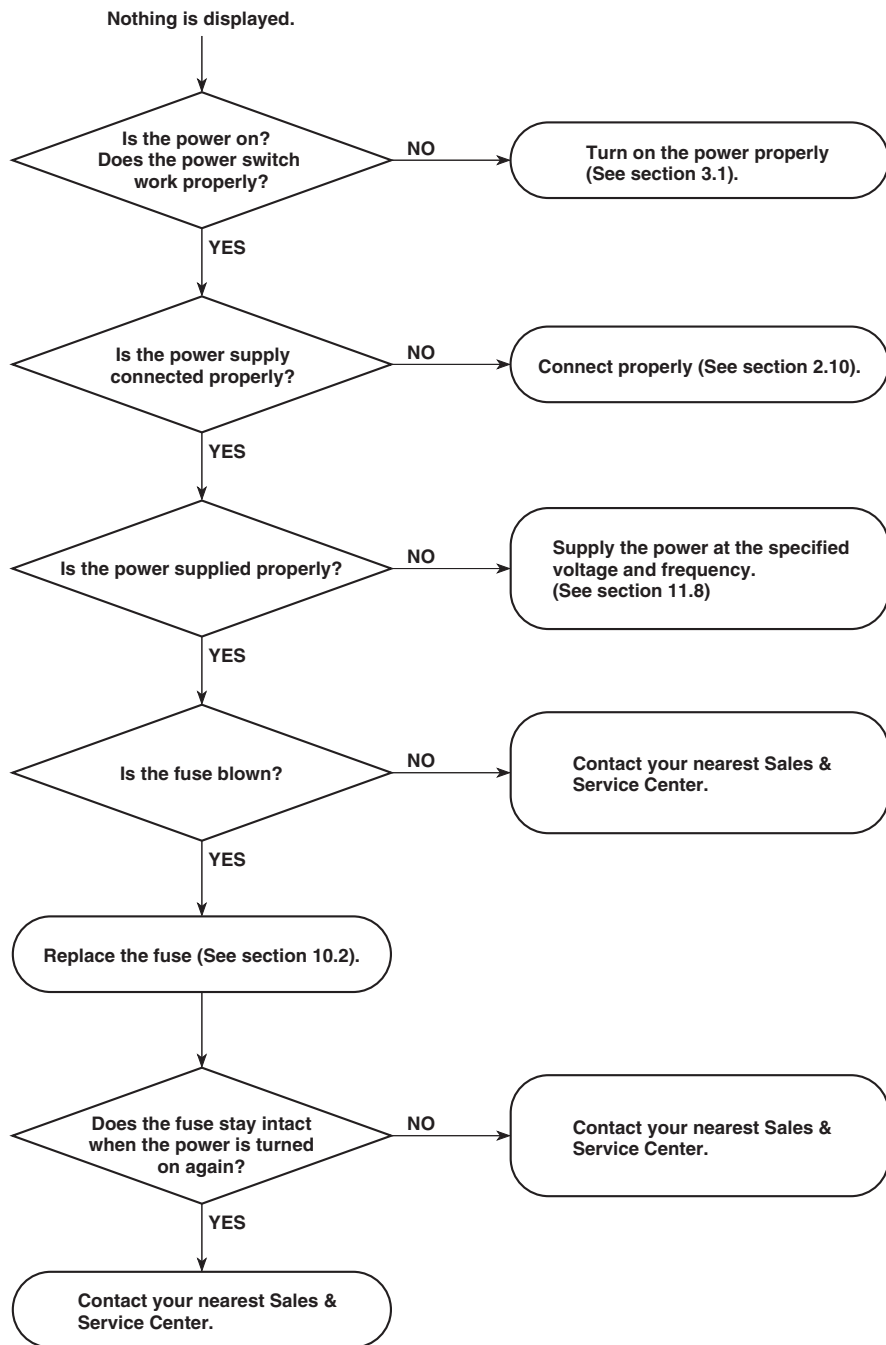

## 9.2 Troubleshooting Flow Chart

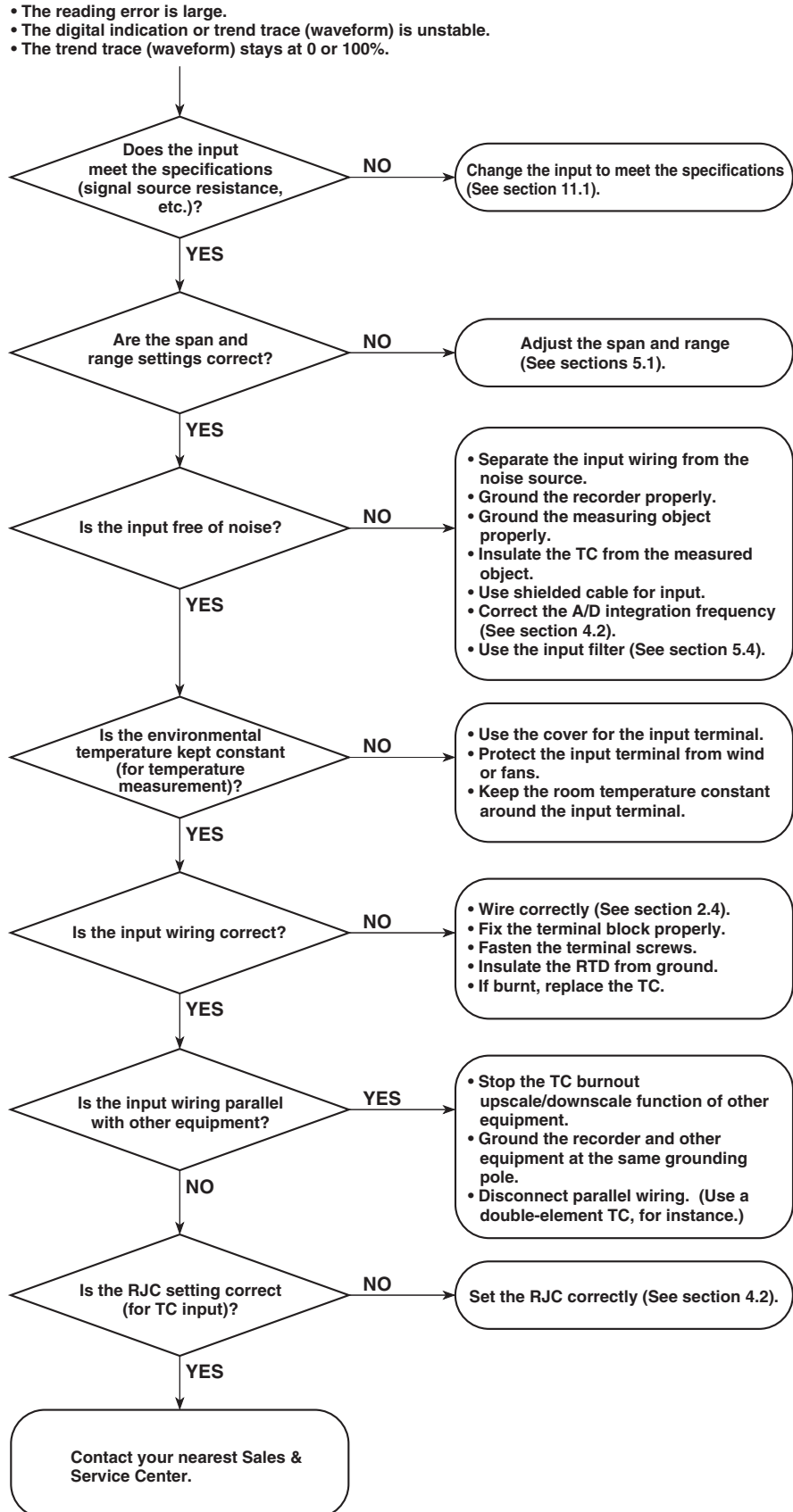

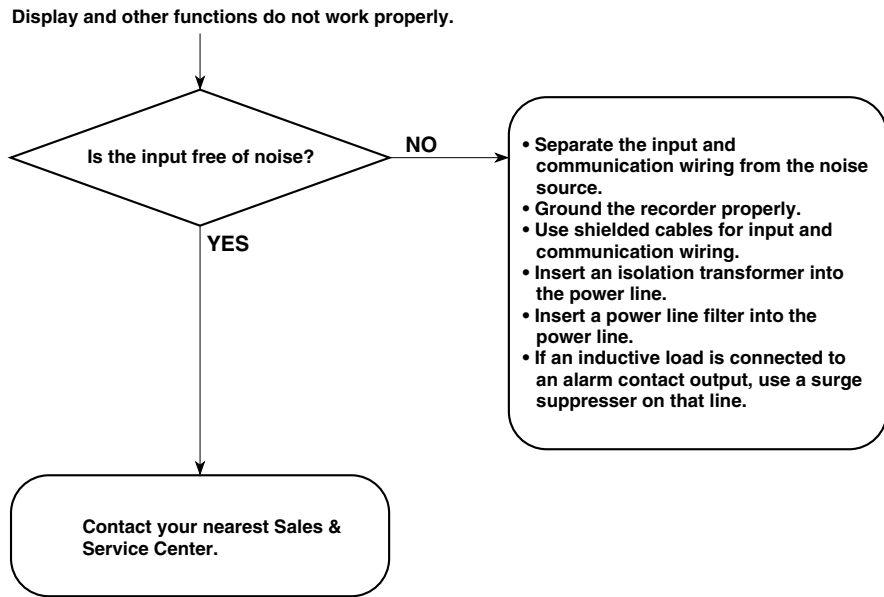

## 10.1 Periodic Maintenance

Check the operation periodically to keep the DX100P in good working order. Perform the following checks and replace worn parts as needed.

- Is the display and storage functioning properly?  
In the event of problems, see section 10.2, “Troubleshooting Flow Chart.”
- Has the brightness of the LCD backlight deteriorated?  
If replacement is necessary, see section 10.4, “Recommended Replacement Periods for Worn Parts.”



## 10.2 Replacing the Fuse

Replace the fuse every two years for preventive maintenance.



### WARNING

- For safety reasons, make sure to turn OFF the power switch and disconnect the DX100P from the main power supply before replacing the fuse.
- To prevent the possibility of fire, use only the specified fuse purchased from YOKOGAWA.
- Never short circuit the fuse holder to bypass the use of a fuse.
- To avoid the possibility of electric shock, open the front panel only when replacing the fuse.
- Do not touch the rear side of the front panel when replacing the fuse, because it can become hot.
- Make sure not to damage the cable while replacing the fuse.

For fuse rating, see section 10.4 “Recommended Replacement Periods for Worn Parts.” Follow the procedures below to replace the fuse.

1. Turn OFF the power switch.
2. Disconnect the DX100P from the main power supply.
3. Open the cover and remove the two screws.
4. Pull the front panel slightly toward you and lift it.
5. While pressing the fuse carrier located to the right of the power switch, turn it counterclockwise approximately 45 degrees. The carrier and the fuse will slide out.
6. Replace with a new fuse, insert the carrier in the fuse holder, and turn it clockwise while pressing the carrier to fix it in place.
7. Lift the front panel slightly, and attach it to the top and then the bottom of the rubber packing. Secure the front panel with screws.

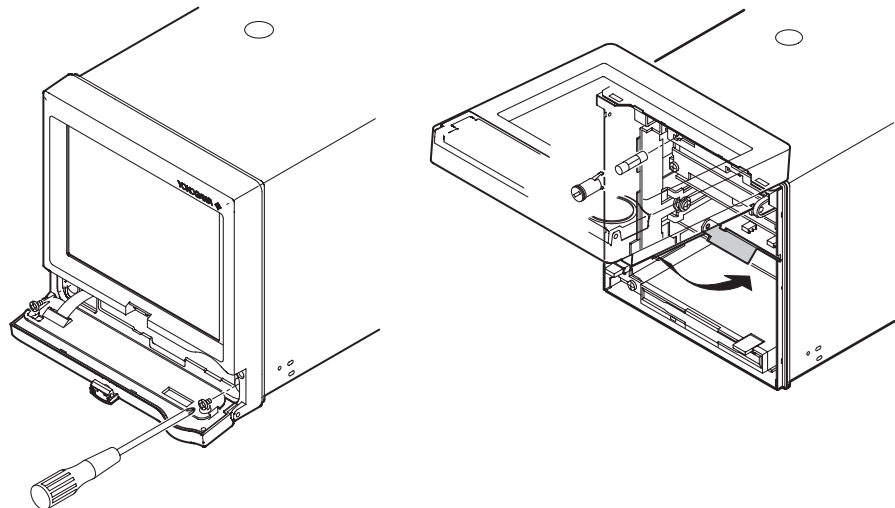

### Note

For DX100Ps which are side-by-side mounted vertically, a front panel always interfere the upper one when it is opened so that front panels except the top one can't be opened directly. First open the top front panel and then the lower one by one. For the same reason, when closing front panels, first close the bottom front panel and then the upper one by one.

## 10.3 Calibration

To maintain the measurement accuracy, we recommend the DX100P be calibrated once a year. Calibration service is also provided by YOKOGAWA dealers. For details, contact your nearest YOKOGAWA dealer.

### Required Instruments

For calibrating the DX100P, calibration instruments with the following resolution are necessary.

#### Recommended Instruments

- DC voltage standard: YOKOGAWA Model 2552 or equivalent  
Main specifications  
Accuracy of output in the range 20 mV to 20 V:  $\pm 0.005\%$
- Decade resistance box: Yokogawa M&C Model 2793-01 or equivalent  
Main specifications  
Accuracy of output in the range 0.1 to 500  $\Omega$ :  
 $\pm(0.01\%+2 \text{ m}\Omega)$   
Resolution: 0.001  $\Omega$

(To purchase these instruments, contact the supplier of the DX100P.)

### Calibration procedure

1. Connect the DX100P and the calibration instruments as shown in the following figure, and allow the instruments to warm-up adequately (The warm-up time for the DX100P is at least 30 minutes).
2. Check that the ambient temperature and humidity are within the normal operating conditions (See chapter 11).
3. Apply input signals corresponding to 0, 50, and 100% of the specified input range and calculate the errors from the readings.  
If the error is not within the accuracy specifications, contact your nearest YOKOGAWA dealer.

#### Note

For TC input, the temperature of the input terminals must be measured and a voltage corresponding to the temperature at the reference junction must be added.

#### DC Voltage Measurement (Example for the DX112P)

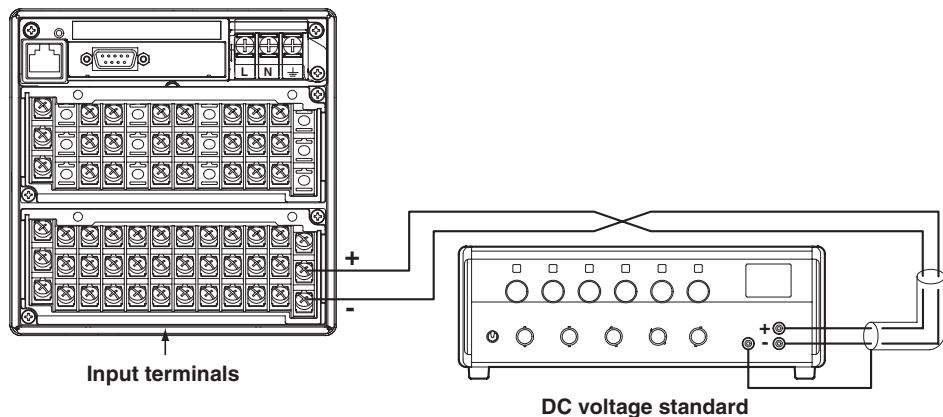

**Temperature Measurement Using the RTD (Example for the DX112P)**

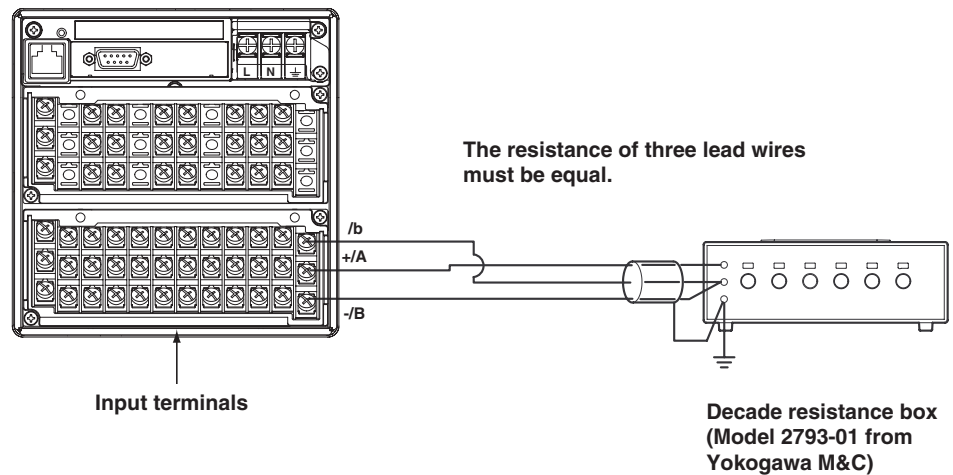

**Temperature Measurement Using the TC (Example for the DX112P)**

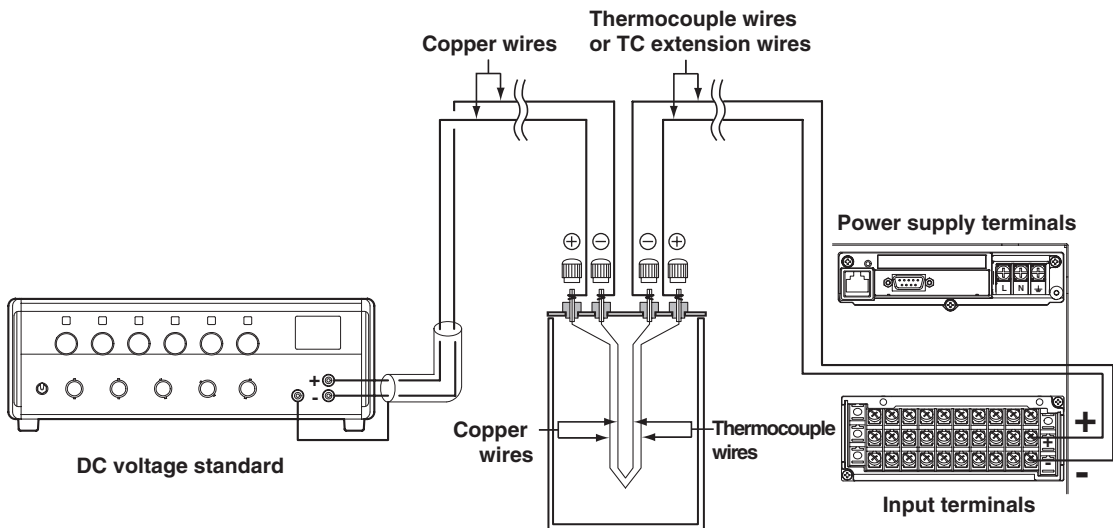

(0°C standard temperature device: Model ZC-114/ZA-10 from Coper Electronics Co., Ltd.)

**Reference Junction Compensation for the Thermocouple Input**

As the measurement terminal of the DX100P is generally at room temperature, the actual output of the thermocouple is different from the values given on the thermoelectromotive force table based on 0°C. The DX100P measures the temperature of the terminal and makes adjustments by calculation. Therefore, when the measurement terminals are shorted (equivalent to 0°C at the detector tip), the temperature at the measurement terminal is displayed. When calibrating the DX100P, this compensation voltage (thermoelectromotive force of 0°C reference corresponding to the input terminal temperature) must be subtracted from the output of the standard generator before application. As shown in the figure, by using the 0°C standard temperature device to compensate the reference junction at 0°C, you can input the thermoelectromotive force of 0°C reference from the DC voltage standard and make the calibration.

## 10.4 Recommended Replacement Periods for Worn Parts

To maintain the reliability of the DX100P and to use it in good working order for a long time, we recommend periodic replacement of worn parts as preventive maintenance.

The recommended replacement periods for worn parts are shown in the following table. The replacement periods apply when the DX100P is operated under standard operating conditions.

Please consider the actual operating conditions when determining the actual replacement periods for your DX100P.

The replacement of the worn parts except the fuse must be conducted by a qualified YOKOGAWA personnel. Contact your nearest YOKOGAWA dealer to have the LCD replaced.

Item	Replacement Period	Part Name	Part Number	Specifications	Quantity Used
Fuse	2 years	FUSE	A1347EF	250 V, 1 A, time lag (except for /P1 model)	1
	2 years	FUSE	A1352EF	250 V, 4 A, time lag (for /P1 model)	1
LCD	5 years	Back light module			1
Battery	10 years	Lithium battery			1
Rubber strip	5 years	Dust and water proof rubber strip		for front panel, for front cover	1 each
Zip drive	5 years				1
PWB assembly	5 years	Power Assy*			1
	5 years	Sub Power Assy*			1
	5 years	AD Assy*			Up to models

\* Replacement Period at the Upper Limit of the Normal Operating Temperature (50°C)  
The replacement period varies depending on the temperature in which the instrument is operated, and the instrument's specifications. If the instrument is used in a 30°C environment, it may be operational for 10 years or more.

### Note

The recommended replacement period for the back light module is the period when the brightness falls to half. The speed of degradation of the brightness varies depending on the operating conditions and the judgement is subjective.

These factors should be considered when determining the actual replacement period.

# 11.1 Input Specifications

Number of inputs:	DX102P: 2 channels DX104P: 4 channels DX106P: 6 channels DX112P: 12 channels
Scan interval:	DX102P, DX104P: 125 ms or 250 ms DX106P, DX112P: 1 s or 2 s (2 s when an A/D integration time is set to 100 ms)
Inputs:	Volt (DC voltage), TC (thermocouple), RTD (resistance temperature detector), DI (digital input), DC current (with external shunt resistor attached)

Input Type and Measurable Range

Input type	Range	Measurable range	
Volt	20 mV	-20.00 to 20.00 mV	
	60 mV	-60.00 to 60.00 mV	
	200 mV	-200.0 to 200.0 mV	
	2 V	-2.000 to 2.000 V	
	6 V	-6.000 to 6.000 V	
	20 V	-20.00 to 20.00 V	
	50 V	-50.00 to 50.00 V	
TC	R <sup>*1</sup>	0.0 to 1760°C	32 to 3200°F
	S <sup>*1</sup>	0.0 to 1760°C	32 to 3200°F
	B <sup>*1</sup>	0.0 to 1820°C	32 to 3308°F
	K <sup>*1</sup>	-200.0 to 1370°C	-328 to 2498°F
	E <sup>*1</sup>	-200.0 to 800°C	-328.0 to 1472.0°F
	J <sup>*1</sup>	-200.0 to 1100°C	-328.0 to 2012.0°F
	T <sup>*1</sup>	-200.0 to 400°C	-328.0 to 752.0°F
	N <sup>*1</sup>	0.0 to 1300°C	32 to 2372°F
	W <sup>*2</sup>	0.0 to 2315°C	32 to 4199°F
	L <sup>*3</sup>	-200.0 to 900°C	-328.0 to 1652.0°F
	U <sup>*3</sup>	-200.0 to 400°C	-328.0 to 752.0°F
RTD <sup>*5</sup>	Pt100 <sup>*4</sup>	-200.0 to 600°C	-328.0 to 1112.0°F
	JPt100 <sup>*4</sup>	-200.0 to 550°C	-328.0 to 1022.0°F
DI	DCV input (TTL)	OFF : less than 2.4 V ON : more than 2.4 V	
	Contact input	Contact ON/OFF	

\*1 R, S, B, K, E, J, T, N: IEC584-1 (1995), DIN IEC584, JIS C1602-1995

\*2 W: W-5% Rd/W-26% Rd (Hoskins Mfg. Co.), ASTM E988

\*3 L: Fe-CuNi, DIN43710, U: Cu-CuNi, DIN43710

\*4 Pt100: JIS C1604-1997, IEC751-1995, DIN IEC751-1996

JPt100: JIS C1604-1989, JIS C1606-1989

\*5 Measuring current: i = 1 mA

A/D integration time:	Selectable from 20 ms (50 Hz), 16.7 ms (60 Hz), 100 ms (50/60 Hz for DX106P and DX112P), or AUTO (automatic selection from 20 ms and 16.7 ms by detection of power supply frequency)
Thermocouple burnout:	Burnout upscale/downscale function can be switched ON/OFF (for each channel). Burnout upscale/downscale selectable
Filter:	DX102P, DX104P: <ul style="list-style-type: none"> <li>• Signal damping</li> <li>• On/off selectable for each channel</li> <li>• Time constant: selectable from 2, 5, and 10 seconds</li> </ul>
Moving average:	DX106P, DX112P: <ul style="list-style-type: none"> <li>• On/off selectable for each channel</li> <li>• Number of samples to be averaged is selectable from 2 to 16</li> </ul>

## 11.1 Input Specifications

---

Computation:	Differential computation: Between any two channels Available for Volt, TC, RTD, and DI ranges.
Linear scaling:	Available for Volt, TC, RTD, and DI ranges. Scaling limits: -30000 to 30000 Decimal point: user selectable Engineering unit: user definable, up to 6 characters
Square root:	Square root computation and linear scaling Available for Volt range. Scaling limits: -30000 to 30000 Decimal point: user selectable Engineering unit: user definable, up to 6 characters

## 11.2 Display Specifications

Display unit:	5.5-inch TFT color LCD (VGA, 240 × 320 dot resolution)
Channel display color:	Trend/Bar graph: Selectable from 16 colors (Red, Green, Blue, Blue violet, Brown, Orange, Yellow green, Lightblue, Violet, Gray, lime, Cyan, Darkblue, Yellow, Light Gray, Purple) Initial settings of channel display color: Channel 1: Red, Channel 2: Green, Channel 3: Blue, Channel 4: Blue violet, Channel 5: Brown, Channel 6: Orange, Channel 7: Yellow-green, Channel 8: Light blue, Channel 9: violet, Channel 10: Gray, Channel 11: Lime 12: Cyan
Trend screen:	Background: White or black selectable Direction: vertical or horizontal selectable Number of indication channels: 6 channels per screen (maximum) All channels indication: 24 channels (maximum, including computation channels) Number of screens: 6 screens (6 group) Line width: 1, 2, and 3 dots selectable Display update rate: Waveform: (One division has 30 dots.) <ul style="list-style-type: none"><li>• DX102P, DX104P: 15 s, 30 s, 1, 2, 5, 10, 15, 20, 30 min., 1, 2, 4, 10 hours/div selectable</li><li>• DX106P, DX112P: 1, 2, 5, 10, 15, 20, 30 min., 1, 2, 4, 10 hours/div selectable</li></ul> Numerical value: 1 s (2 s when the scan interval is 2 s.) Contents: Waveform, Numerical value (numerical display section can be turned ON/OFF), scale (scale display can be turned ON/OFF), grid lines (number of divisions selectable from 4 to 12), times on time axis, trip lines (line widths are selectable from 1, 2 and 3 dots), messages (up to 32 characters for each), alarm indication Zone display and partial expanded display are available.
Digital screen:	Number of indication channels: 6 channels per screen (maximum) Number of screens: 6 screens (6 group) Display update rate: 1 s (2 s when the scan interval is 2 s) Contents: Numerical value, unit, alarm indication
Bar graph screen:	Direction: Vertical or horizontal selectable Number of indication channels: 6 channels per screen (maximum) Number of screens: 6 screens (6 group) Scales: 4 to 12 divisions selectable Base position of bar: Left, right or center (only for horizontal display) Display update rate: 1 s (2 s when the scan interval is 2 s) Contents: Bar graph, numerical value, unit, scale, alarm indication

## 11.2 Display Specifications

---

Automatic display switching:	<p>The displayed group can be automatically changed on the trend, digital, and bar graph screens.</p> <p>The display switching interval is selectable from 5 s, 10 s, 20 s, 30 s, and 1 min.</p>
Overview screen:	<p>Displays measured values and alarm status of all channels.</p> <p>Alarm ACK for individual alarms can be executed.</p>
Information screen:	<p>Alarm summary: Displays the list of alarms. Capable to switch to historical trend screen by cursor pointing.</p> <p>Alarm ACK summary: Display the list of alarm ACK operations.</p> <p>Message summary: Display the list of messages and time. Capable to switch to historical trend screen by cursor pointing.</p> <p>Memory summary: Display the file list in internal memory. Capable to switch to historical trend screen by cursor pointing.</p> <p>Report data display (/M1 option): Display the report data in internal memory.</p>
Tags:	<p>Number of characters: 16 characters maximum</p>
Historical trend screen:	<p>Displays the retrieved data from internal memory.</p> <p>Time axis operation: Can be expanded, reduced, and scrolled</p> <p>Memory information: The following information of the retrieved data are displayed: Data type, serial number of the DXP which is used to acquire data, starting and ending time of data acquisition, user name, batch information, and sign record</p>
Sign record screen:	<p>Enables you to sign display data and event data.</p> <ul style="list-style-type: none"><li>• Displays the historical trend of the display data or event data on the external storage medium.</li><li>• Can display the operation log, alarm summary, alarm ACK summary, and message summary that accompany the data.</li><li>• Can display the file information.</li></ul>
Log screen:	<p>Displays logs of operation errors, operations, communication commands, file transfers via FTP, Web operations, e-mail transmissions, access to the SNTP server, and setting changes.</p>
System screen:	<p>Displays the number of input points, capacity of the internal memory, options, remote controller ID (/KB1, /KB2 options), MAC address, and firmware version number.</p>
Backlight saver function:	<p>The LCD backlight automatically dims if no key is pressed for a certain preset time (can be set from 1, 2, 5, 10, 30 and 60 minutes).</p>
Display language:	<p>Selectable from English, German, French, and Japanese.</p>
Temperature unit:	<p>°C or °F selectable</p>



## 11.3 Data Storage Specifications

- External storage medium: Selectable from:
- PCMCIA ATA flash memory card (4 to 440 MB), or CF card (32 to 512 MB, adapter required)
  - Zip disk (100 MB or 250 MB)
- File types: The following two file types can be created.
- Event data file (stores instantaneous values acquired periodically at a specified sampling interval)
  - Display data file (stores the maximum and minimum values for each sampling interval from among measured data acquired at scan intervals)
- Data format: Binary
- Automatic saving:
- When the type of process is set to “Batch”
    - Display data: Saved to the external storage medium at maximum applicable interval
    - Event data: Saved to the external storage medium at maximum applicable interval
  - When the type of process is set to “Continue”
    - Display data: Saving at specified times / periodic saving (10 min to 31 days) to external storage medium
    - Event data: Saving at specified times / periodic saving (3 min to 31 days) to external storage medium
- Save operation: Cyclic use of the storage area is possible (Media FIFO)
- Sampling interval: Display data: Linked with the waveform display update rate  
Event data: Specified sampling interval
- Sampling interval for event data: A sampling interval that is faster than the scan interval cannot be specified.
- DX102P, DX104P:  
Selectable from 125, 250, 500 ms, and 1, 2, 5, 10, 30, 60, 120, 300, 600 s
- DX106P, DX112P:  
Selectable from 1, 2, 5, 10, 30, 60, 120, 300, and 600 s
- Sampling length: The maximum sampling length (the maximum data length) can be derived from the following equation.
- $$\text{Maximum sampling length} = \text{the maximum sampling count} \times \text{sampling interval}$$
- Maximum sampling count: calculated from internal memory capacity (5 MB), types of data, data size, and number of measurement and computation channels data to be stored
- Data size per channel:

Data type	Measurement channel	Computation channel
Display data	4 bytes/datum	8 bytes/datum
Event data	2 bytes/datum	4 bytes/datum

### 11.3 Data Storage Specifications

Maximum sampling count:

Sampling date and time (8 bytes) is attached.

Data type	Maximum sampling count
Display data	5,000,000 bytes/(number of measurement channels × 4 + number of computation channels × 8 + 8)
Event data	5,000,000 bytes/(number of measurement channels × 2 + number of computation channels × 4 + 8)

Example of the maximum sampling length:

In case measurement ch = 4 ch, computation ch = 0 ch

Display data (approx.)

Display rate (min/div)	1 min	5 min	20 min	30 min	60 min	240 min
Sampling interval (s)	2 s	10 s	40 s	60 s	120 s	480 s
Sampling length	115 h	24 days	96 days	144 days	289 days	1157 days

Event data (approx.)

Sampling interval	125 ms	250 ms	1 s	5 s	30 s	120 s
Sampling length	10 h	21 h	86 h	18 days	108 days	434 days

In case measurement ch = 6 ch, computation ch = 0 ch

Display data (approx.)

Display rate (min/div)	1 min	5 min	20 min	30 min	60 min	240 min
Sampling interval (s)	2 s	10 s	40 s	60 s	120 s	480 s
Sampling length	86 h	18 days	72 days	108 days	217 days	863 days

Event data (approx.)

Sampling interval	1 s	5 s	10 s	30 s	60 s	120 s
Sampling length	69 h	14 days	28 days	86 days	173 days	347 days

Manual sampled data: Trigger: Key operation, communication command, or remote input signals (/R1 option)

Data format: ASCII

Max. number of data sets internal memory can hold: 50

TLOG data (/M1 option):

Trigger: Timeout of the timer

Data format: Binary

Max. number of data sets or data divisions internal memory can hold: 400 data sets or 16 divisions (number of computation start/stop operations)

Report data (/M1 option):

Types: Hourly, daily, hourly + daily, daily + monthly, and daily + weekly

Data format: ASCII

Max. number of report data internal memory can hold: 50

Screen image data:

Trigger: Key operation, communication command, or remote input signals (/R1 option)

Data format: png format

Output: To external storage medium

## 11.4 Alarm Function Specifications

Number of alarms:	Up to four alarms for each channel
Alarm types:	Upper and lower limits, delay upper and lower limits, difference upper and lower limits, and upper limit and lower on rate-of-change
Alarm delay time:	Selectable from 1 s to 3600 s for each channel
Interval time of rate-of-change alarms:	The scan interval times 1 to 15, common to all channels.
Display:	The alarm status (type) is displayed in the numerical value display area upon occurrence of an alarm. A common alarm indication is also displayed in the status display section. The alarm indication behavior: non-hold or hold-type can be selectable for common to all channels (Only hold-type is selectable when output relay action is set to "hold").
Hysteresis:	On (0.5% of display span)/off selectable (applied to upper and lower limits alarms, common to all measurement channels)
Relay outputs (option):	Number of points: 2, 4, or 6 points Relay action: Energized/de-energized, hold/non-hold, AND/OR, reflash actions selectable. The alarm relay condition is held even in the system mode.
Alarm information:	Alarm types, date and time of alarm occurrences/releases. Up to 240 latest alarms are stored in the internal memory. Displayed on the alarm summary screen.
Alarm ACK information:	Alarm types, date and time of alarm ACK operation, user name. Up to 240 latest alarms are stored in the internal memory. Displayed on the alarm ACK summary screen.

---

## 11.5 Specifications of the Function Used to Manage the Data

Supports 21 CFR Part 11 of the FDA (Food and Drug Administration).

- Login Function: Users enter identification information. The user can operate the DX100P when the user is confirmed as a registered user.
- User types:
- Administrator: 3 administrators
    - Able to perform all operations.
    - Login method: Key only or Key and via communications
  - User: 90 users
    - Set the range of operations allowed for each user. System mode operations are not allowed. Time set operation is not allowed.
    - Login method: Key only, via communications only, or Key and via communications
- User identification:
- User name, user ID, and password are used.
  - Combinations of user ID and password that have been used in the past cannot be used.
- Auto logout: Logged out when there is no key operation for a specified time.
- When logged out: Operation of switching the operation screen is possible.
- User identification: User name, user ID, and password are used.
- Combinations of user ID and password that have been used in the past cannot be used.
- Audit trail function: Saving of operation log:
- The operation log from the previous Memory Stop to the current Memory Stop is added to the data file.
- Number of operation logs: Up to 2000
- Saving of setting change log and setup file:
- The log of setting changes is saved to the external storage medium.
  - The setup file when settings have been changed is saved to the external storage medium.
- Electronic signature function:
- Adds approval information (electronic signature) to the display data file or event data file.
  - Information that can be added:
    - User name, date and time, pass/fail, and comment
  - User identification: User ID and password
  - Sign authority level: One of three authority levels or no authority can be specified.
  - Approval information cannot be added if errors exist in the data.
  - Approval information that has been added cannot be erased or changed.
- Applicable files
- When the type of process is set to "Batch"
    - Data file that is not divided (1 data file/batch)
  - When the type of process is set to "Continue"
    - All data files

## 11.5 Specifications of the Function Used to Manage the Data

---

Batch function: Adds batch information to the display data file or event data file.  
Information that can be added to the data:  
DX100P serial No., headers 1 to 3, batch number, lot number, date and time of Memory Start and user name, date and time of Memory Stop and user name, and comment.

Data format of measured/computed data and setup data:  
Display data, event data, TLOG data, and setup data are in BINARY format (undisclosed).

---

## 11.6 Specifications of Communication Functions

Connection:	Ethernet (10BASE-T)
Protocols:	FTP, TCP, IP, UDP,ICPM, ARP, HTTP, SMTP
FTP client functions:	Automatic file transport from the DX100P (FTP client protocol) Files that can be transported: Display data file, event data file, setup file, setting change log file, report data file, and screen image data file
FTP server functions:	Directory information output and file output on the external storage medium on request of FTP client.
Setting/Measurement server:	Registered users can log in via Ethernet. A proprietary protocol is used. Setting function: <ul style="list-style-type: none"><li>• Outputs measured data (real time monitor is possible).</li><li>• Outputs logs, setup data, screen image data, status info., and login info.</li><li>• Outputs files on the external storage medium.</li><li>• Operates the DX100P.</li><li>• Configures the DX100P.</li></ul> Real time monitor function: Monitor the measured/computed data of the DX100P. Monitor function <ul style="list-style-type: none"><li>• Outputs measured data (real time monitor is possible).</li><li>• Outputs logs, setup data, screen image data, status info., and login info.</li></ul>
E-mail transmission function:	E-mail is automatically transmitted at the following times. Alarm occurrence/release, recovery from a power failure, memory end detection, occurrence of error related to the external storage medium and FTP client, occurrence of locked user, at the specified time, and report creation. Destination: Specify two groups of destinations.
Web server function:	Displays the DX100P screen on the Internet Explorer browser. <ul style="list-style-type: none"><li>• Browser: Microsoft Internet Explorer 4.0 to 5.5</li><li>• Monitor page: For monitoring</li><li>• Operator page: Switches the screen on the DX100P from the browser. When the login function is not used, writing message and alarm ACK operation are possible.</li><li>• Access control (user name (up to 8 characters) and password (up to 20 characters)) on each page is available.</li></ul>
Maintenance/Test server:	Registered users can log in via Ethernet. Setting function: <ul style="list-style-type: none"><li>• Outputs connection information and network information.</li><li>• Closes other connections.</li></ul> Setting function: <ul style="list-style-type: none"><li>• Outputs connection information and network information.</li></ul>
Instrument information server:	Outputs the serial number and model of the DX100P.
SNTP server:	Operates as an SNTP server. Time resolution is 15.625 milliseconds.
SNTP client:	Synchronizes to the time of the SNTP server on the network.

## 11.7 Specifications of Optional Functions

### Alarm Output Relays (/AR1, /AR2, /A3):

An alarm signal is output from the rear panel as a relay contact signal.

/AR1 and /AR2 includes remote control functions (/R1)

Number of output relays: 2, 4, or 6

Relay contact rating: 250 VAC (50/60 Hz)/3 A, 250 VDC/0.1 A (for resistance load)

Terminal configuration: SPDT (NO-C-NC). Energized-at-alarm/de-energized-at-alarm, AND/OR, hold/non-hold, and reflash actions are selectable.

### Serial Communication Interface (/C2, /C3):

Allows communications using one of four protocols.

Connection: EIA RS-232 (/C2) or RS-422A/485 (/C3)

Protocols: Normal (setting/measurement function), Modbus master/slave protocol, and bar code protocol (/C2)

Synchronization method: Start-stop asynchronous transmission

Connection method (RS-422A/485):

4-wire half-duplex multi-drop connection

(1 : N where N = 1 to 31)

Transmission speed: 1200, 2400, 4800, 9600, 19200 or 38400 bps

Data length: 7 or 8 bits

Stop bit: 1 bit

Parity: Odd, even, or none

Communication distance (RS-422A/485): Up to 1200 m

Application:

- Setting/measurement function:

A proprietary protocol is used.

For details, see "Setting/measurement server," section 11.6.

- Modbus:

Mode: RTU SLAVE, RTU MASTER

Data type: SLAVE: Data read and data write by the master device

MASTER: Data read from the slave device  
(Computation function /M1 is necessary)

- Bar code input:

A proprietary protocol is used.

Reads bar codes to operate the DX100P.

### FAIL/Memory End Output (/F1):

One of the following five functions can be assigned to each of two output relays.

Contact specifications: 250 VDC/0.1 A (resistive load), 250 VAC (50/60 Hz)/3 A

- System fail

Relay action: De-energized on system fail

- Memory end

Informs of the time until end of the internal memory space before the data is overwritten, or of the time when the remaining space on the external storage medium reaches to 10% of whole capacity or 6 Mbytes.

Relay action: Energized when the remaining spaces reaches the specified value.

Memory alarm time: selectable from 1, 2, 5, 10, 20, 50 or 100 hours

## 11.7 Specifications of Optional Functions

---

- Memory Start/Memory Stop  
Relay action: Energized on Memory Start, de-energized on Memory Stop
- User Locked  
Relay action: Energized on occurrence of locked user, de-energized on the operation of acknowledging the user lock
- Presence of Login Users  
Relay action: Energized when there is a user logged into the DX100P, otherwise, de-energized

### Clamped Input Terminal (/H2):

Clamped input terminal is used for input terminal.

### Desktop Type (/H5[ ]):

Provides carrying handle.

/H5D, /H5F/, H5R, or /H5J: Power cord is provided.

/H5: Screw type power terminal (can only be specified when /P is simultaneously specified).

### Computation Functions (/M1):

Can perform computation, display the computed data assigned to channels in trends and numerical values, and store computed data.

Channels assignable to computed data:

DX102P, DX104P: Up to 8 channels

DX106P, DX112P: Up to 30 channels

Operation:

General arithmetic operations:

Four arithmetic operations, square root, absolute, common logarithm, exponential, power, relational operations (<, ≤, >, ≥, =, ≠), logical operations (AND, OR, NOT, XOR)

Statistical operations (TLOG computation): Average, maximum, minimum, summation, and maximum - minimum  
Special operations: Rolling average (moving average on computed results)

Constant:

Available (Up to 12 constants)

Digital input data via communication:

Digital data via communication can be used in calculation expression (Up to 12 data)

Remote input status (/R1 option):

Remote input status (0/1) can be used in calculation expression (Up to 8 inputs)

TLOG data

The instantaneous values of all channels (excluding measurement channels set to skip and computation channels set to Off) can be saved from the time computation is started to the time computation is stopped at intervals specified by a timer.

Report functions:

Report type: Hourly, daily, hourly + daily, daily + monthly, and daily + weekly

Operation: Average, maximum, minimum and summation

Report channel: Up to 12 channels per report

Data format: ASCII



**Cu10, Cu25 RTD Input/3 terminal isolated RTD Input (/N1):**

This option allows Cu10 and Cu25 inputs besides the standard input types. A, B, and b terminals are of isolated input type for DX106P and DX112P.

	Input type	Measuring range
RTD (measurement current : i = 1.25 mA)	Cu10 (GE)	-200 to 300°C (-328.0 to 572.0°F)
	Cu10 (L&N)	
	Cu10 (WEED)	
	Cu10 (BAILEY)	
	Cu10 : $\alpha = 0.00392$ at 20°C	
	Cu10 : $\alpha = 0.00393$ at 20°C	
	Cu25 : $\alpha = 0.00425$ at 0°C	

Measuring accuracy (For measuring accuracy of other input types, see section 11.8.)

Input type	Accuracy guaranteed range	Measuring accuracy
Cu10 (GE)	-70 to 170°C	± (0.4% of rdg + 1.0°C)
Cu10 (L&N)	-75 to 150°C	
Cu10 (WEED)	-200 to 260°C	
Cu10 (BAILEY)	-200 to 300°C	
Cu10 : $\alpha = 0.00392$ at 20°C		
Cu10 : $\alpha = 0.00393$ at 20°C		
Cu25 : $\alpha = 0.00425$ at 0°C		± (0.3% of rdg + 0.8°C)
Pt100 Jpt100	Measuring range	± (0.3% of rdg + 0.6°C)

**3 terminal Isolated RTD Input (/N2):**

A, B, and b terminals are of isolated input type.

\* Can be specified only for DX106P and DX112P.

A, B, and b terminals of DX102P and DX104P are isolated as standard.

**24 VDC/AC Power Supply (/P1):**

Powered by 24 VDC or 24 VAC.

For related specifications, see “Power Supply,” “Normal Operating Conditions,” “Effects of Operating Conditions,” and “Other Specifications” in section 11.8.

Rated power supply: 24 VDC/AC

Allowable power supply voltage range:

21.6 to 26.4 VDC/AC

Dielectric strength: Power supply to ground terminal: 500 VAC (50/60 Hz), 1 minute

Rated power supply frequency: 50/60 Hz (for AC)

Allowable power supply frequency range: 50/60 Hz±2% (for AC)

Rated power consumption: 30 VA (for DC), 45 VA (for AC)

Power consumption:

Supply voltage	Backlight saving mode	Normal	Max.
24 VDC	17 VA	19 VA	30 VA
24 VAC(50/60Hz)	28 VA	32 VA	45 VA

Effects on measured value:

With variation within 21.6 to 26.4 V (50/60 Hz):

±1 digit or less

With variation of ±2 Hz from rated power supply frequency (at 24 VAC):

±(0.1% of rdg + 1 digit) or less

**Calibration Correction (/CC1):**

Corrects the measured value of each channel using ten-segment linearizer approximation.

Can be set on each measurement channel.

Number of segment points: 2 to 16

**Remote Control (/R1):**

This option allows the following functions to be controlled remotely by a contact or an open collector input (up to eight inputs):

- Alarm acknowledgment (trigger, 250 ms or longer)
- Memory Start/Memory Stop (rising and falling edge)
- Time adjustment (adjusting the internal clock to the nearest hour upon remote signal, trigger, 250 ms or longer)

The table below shows the operation when data acquisition is stopped. The time is gradually corrected while data acquisition is in progress.

Time of signal input	Processing
hh:00:00 to hh:01:59	Cut off reading of less than one minute. e.g. 10:00:50 is corrected as 10:00:00
hh:58:00 to hh:59:59	Round up reading of less than one minute. e.g. 10:59:50 is corrected as 11:00:00
hh:02:00 to hh:57:59	No process is to be performed.

- Start/stop of computation (rising and falling edge, /M1 option)
- Reset of computation data (trigger, 250 ms or longer, /M1 option)
- Manual sampling (trigger, 250 ms or longer)
- Writing messages (Up to 8 different messages can be set, trigger, 250 ms or longer)
- Snapshot (saves the current screen image data to the external storage medium)

**24 VDC Power Supply for Transmitter (/TPS2 or /TPS4)**

- Number of loops: 2 (/TPS2) or 4 (/TPS4)
- Output voltage: 22.8 to 25.2 VDC (under rated output current)
- Rated output current: 4 to 20 mADC
- Maximum output current: 25 mADC (overcurrent protection operation current: approximately 68 mADC)
- Allowable cable resistance:  $RL \leq (17.8 - \text{minimum operation voltage of transmitter})/0.02 \text{ A}$   
 where  $17.8 \text{ V} = 22.8 \text{ V} - 5 \text{ V}$   
 22.8 V: Minimum output voltage  
 5 V: Maximum voltage across the load resistor (250 Ω)
- Maximum length of cable: 2 km (when using CEV cable)
- Insulation resistance: 20 MΩ or more (500 VDC) between output terminal and ground terminal
- Withstand voltage: 500 VAC (50/60 Hz, I = 10 mA) for one minute between output terminal and ground terminal  
 500 VAC (50/60 Hz, I = 10 mA) for one minute between output terminals

**Easy Text Entry (/KB1, /KB2)**

/KB1: With a remote control terminal, /KB2: Without remote control terminal

Operation temperature range: 0 to 40°C

Operation humidity range: 20 to 80% RH (5 to 40°C, no condensation)

Storage temperature range: -10 to 60°C

Power supply: 3 VDC, two AAA batteries (alkaline or manganese. Use the same type of batteries.)

Weight: Approx. 60 g (excluding the batteries)

External dimensions: 170 (H) × 50 (W) × 23.7 (D) mm

Number of units that can be controlled individually:  
Up to 32 units by setting the ID number

Control range: 8 m or less from the front of the light-receiving section of the DX100P. (A reference value.\* Varies depending on the operating environment such as the battery voltage and the presence or absence of external light.)

\* The value is not warranted.

Directional characteristics: See the figure below. (A reference value.\* Varies depending on the operating environment such as the battery voltage and the presence or absence of external light.)

\* The value is not warranted.

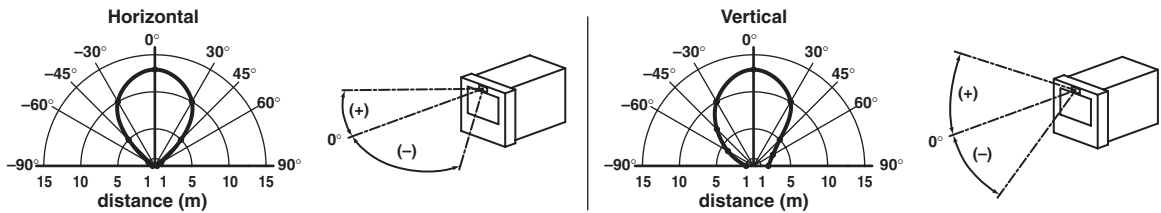

# 11.8 General Specifications

## Construction

Mounting:	Flush panel mounting (on a vertical plane) Mounting may be inclined backward up to 30 degrees from a horizontal plane.
Allowable panel thickness:	2 to 26 mm
Material:	Case: drawn steel Bezel: polycarbonate
Case Color:	Case: Grayish blue green (Munsell 2.0B 5.0/1.7 or equivalent) Bezel: Charcoal grey light (Munsell 10B 3.6/0.3 or equivalent)
Front Panel:	Water and dust-proof (based on IEC529-IP65, and NEMA No.250 TYPE4 (except External Icing Test))
Dimensions:	144(W) × 144(H) × 241.4(D) mm
Weight:	DX102P: approx. 2.9 kg DX104P: approx. 3.0 kg DX106P: approx. 3.0 kg DX112P: approx. 3.0 kg

## Standard Performance

Measuring accuracy:

The following specifications apply to operation of the DX100P under standard operation conditions:

Temperature:	23 ± 2°C
Humidity:	55% ± 10% RH
Power supply voltage:	90 to 132 or 180 to 250 VAC
Power supply frequency:	50/60 Hz ± 1%
Warm-up time:	At least 30 minutes.
Other ambient conditions such as vibration should not adversely affect the operation of the DX100P.	

Input	Range	Measuring accuracy (digital display)	Max. resolution of digital display
DC voltage	20 mV	± (0.1% of rdg + 2 digits)	10 μV
	60 mV		10 μV
	200 mV		100 μV
	2 V		1 mV
	6 V		1 mV
	20 V		10 mV
	50 V		± (0.1% of rdg + 3 digits)
TC (Excluding the reference junction compensation accuracy)	R	± (0.15% of rdg + 1°C) However, R, S : ± 3.7°C at 0 to 100°C, ± 1.5°C at 100 to 300°C	0.1°C
	S	B : ± 2°C at 400 to 600°C (Accuracy at less than 400°C is not guaranteed.)	
	B	± (0.15% of rdg + 0.7°C) However, ± (0.15% of rdg + 1°C) at -200 to -100°C	
	K	± (0.15% of rdg + 0.5°C)	
	E	± (0.15% of rdg + 0.5°C)	
	J	± (0.15% of rdg + 0.5°C)	
	T	However, ± (0.15% of rdg + 0.7°C) at -200 to -100°C	
	N	± (0.15% of rdg + 0.7°C)	
	W	± (0.15% of rdg + 1°C)	
	L	± (0.15% of rdg + 0.5°C)	
	U	However, ± (0.15% of rdg + 0.7°C) at -200 to -100°C	
RTD	Pt100	± (0.15% of rdg + 0.3°C)	
	JPt100		

Measuring accuracy in case of scaling (digits):

Accuracy during scaling (digits) = measuring accuracy (digits) × multiplier + 2 digits (rounded up)

where the multiplier = scaling span (digits)/measuring span (digits).

Example: Assuming that

- range: 6 V
- measuring span: 1.000 to 5.000 V
- scaling span: 0.000 to 2.000

Then,

Measuring accuracy =  $\pm(0.1\% \times 5 \text{ V} + 2 \text{ digits})$   
 =  $\pm(0.005 \text{ V [5 digits]} + 2)$   
 =  $\pm(7 \text{ digits})$

Multiplier =  $2000 \text{ digits (0.000 to 2.000)}/4000 \text{ digits (1.000 to 5.000 V)}$   
 = 0.5

Accuracy during scaling =  $7 \text{ digits} \times 0.5 + 2 = 6 \text{ digits (rounded up)}$

Reference junction compensation:

Internal/External selectable for each channel

Reference junction compensation accuracy (above 0°C):

Types R, S, B, W:  $\pm 1^\circ\text{C}$

Types K, J, E, T, N, L, U:  $\pm 0.5^\circ\text{C}$

Maximum allowable input voltage:

$\pm 10 \text{ V DC (continuous)}$  for ranges of 2 V or less and TC ranges

$\pm 60 \text{ V DC (continuous)}$  for 6 V DC, 20 V DC, and 50 V DC

ranges

Input resistance:

Approximately 10 M $\Omega$  or more for ranges of 2 V DC or less and TC

Approximately 1 M $\Omega$  for 6 V DC, 20 V DC, and 50 V DC ranges

Input source resistance:

Volt, TC: 2 k $\Omega$  or less

RTD: 10  $\Omega$  or less per wire (The resistance of all three wires must be equal).

Input bias current: 10 nA or less

Maximum common mode noise voltage: 250 Vrms AC (50/60 Hz)

Maximum noise voltage between channels: 250 Vrms AC (50/60 Hz)

Interference between channels:

120 dB (when the input source resistance is 500  $\Omega$  and the

inputs to other channels are 60 V)

Common mode rejection ratio:

120 dB (50/60 Hz  $\pm 0.1\%$ , 500  $\Omega$  imbalance, between the minus terminal and ground)

Normal mode rejection ratio: 40 dB (50/60 Hz  $\pm 0.1\%$ )

## Power Supply

Rated power supply:

100 to 240 VAC (automatic switching, except /P1 model)

24 VDC/AC (/P1 model)

Allowable power supply voltage range:

90 to 132 or 180 to 264 VAC (except /P1 model)

21.6 to 26.4 VDC/AC (/P1 model)

Rated power supply frequency:

50/60 Hz (automatic switching, for AC)

Rated Power consumption:

62 VA (except /P1 model)

30 VA (/P1 model, DC), 45 VA (/P1 model, AC)

## 11.8 General Specifications

Power consumption: Except /P1 model

Supply voltage	Backlight saving mode	Normal	Max.
100 VAC	30 VA	32 VA	45 VA
240 VAC	42 VA	47 VA	62 VA

/P1 model

Supply voltage	Backlight saving mode	Normal	Max.
24 VDC	17 VA	19 VA	30 VA
24 VAC(50/60Hz)	28 VA	32 VA	45 VA

### Normal Operating Conditions

Power supply voltage: 90 to 132 VAC or 180 to 250 VAC (except /P1 model)  
21.6 to 26.4 VDC/AC (/P1 model)

Power supply frequency:

Ambient temperature: 0 to 50°C (when using Zip drive: 5 to 40°C)

Ambient humidity: 20% to 80% RH (at 5 to 40°C)

Vibration: 10 to 60 Hz, 0.2 m/s<sup>2</sup> or less

Shock: Not acceptable

Magnetic field: 400 A/m or less (DC and 50/60 Hz)

Noise: Normal mode (50/60 Hz):  
Volt: The peak value including the signal must be less than 1.2 times the measuring range.  
TC: The peak value including the signal must be less than 1.2 times the measuring thermal electromotive force.  
RTD: 50 mV or less  
Common mode noise (50/60 Hz):  
250 Vrms AC or less for all ranges  
Maximum noise voltage between channels (50/60 Hz):  
250 Vrms AC or less

Mounting position: Can be inclined up to 30 deg backward. Mounting at an angle away from the perpendicular is not acceptable.

Warm-up time: At least 30 minutes after power on

Altitude: 2000 m or less above sea level

### Effects of Operating Conditions

Ambient temperature: With temperature variation of 10°C:  
• ±(0.1% of rdg + 1 digit) or less for Volt and TC ranges  
Excluding the error of reference junction compensation  
• ±(0.1% of rdg + 2 digit) or less for RTD ranges

Power supply: Except /P1 model  
• With variation within 90 to 132 V and 180 to 250 VAC (50/60 Hz): ±1 digit or less  
• With variation of ±2 Hz from rated power frequency (at 100 VAC): ±(0.1% of rdg + 1 digit) or less  
/P1 model  
• With variation within 21.6 to 26.4 VDC/AC: ±1 digit or less  
• With variation of ±2 Hz from rated power frequency (at 24 VAC): ±(0.1% of rdg + 1 digit) or less

Magnetic field: AC (50/60 Hz) and DC 400 A/m fields:  
±(0.1% of rdg + 10 digits) or less

- Input source resistance: Volt range
- With variation of +1 k $\Omega$ :  
 Ranges of 2 V or less: within  $\pm 10 \mu\text{V}$   
 Ranges of 6 V or greater:  $\pm 0.1\%$  of rdg or less
- TC range
- With variation of +1 k $\Omega$ :  
 Within  $\pm 10 \mu\text{V}$  ( $\pm 100 \mu\text{V}$  when the burnout upscale/  
 downscale function is switched on)
- RTD range (Pt100)
- With variation of 10  $\Omega$  per wire (resistance of all three wires  
 must be equal):  $\pm 0.1\%$  of rdg + 1 digit) or less
  - With maximum difference of 40 mhos between wires:  
 approximately 0.1 $^{\circ}\text{C}$

### Transport and Storage Conditions

The following specifies the environmental conditions required during transportation from shipment to the start of service and during storage as well as during transportation and storage if the DX100P is temporarily taken out of service.

No malfunction will occur under these conditions with serious damage, which is impossible to repair; however, calibration may be necessary to recover normal operation performance.

- Ambient temperature:  $-25^{\circ}\text{C}$  to  $60^{\circ}\text{C}$   
 Humidity: 5% to 95% RH (No condensation is allowed).  
 Vibration: 10 to 60 Hz, 4.9 m/s<sup>2</sup> maximum  
 Shock: 392 m/s<sup>2</sup> maximum (while being packed)

### Other Specifications

- Clock: With calendar function (year of grace)  
 When the time is changed while data acquisition is in progress, the time is corrected by 15.625 milliseconds per a second.  
 The time can be adjusted by a remote contact (with the remote control option).
- Daylight saving: Automatically sets the internal clock ahead by 1 hour during the specified period in the year.
- Accuracy of clock:  $\pm 100$  ppm, excluding a delay (of 1 second, maximum) caused each time the power is turned on.
- Memory backup: A built-in lithium battery backs up the setup parameters (battery life: approximately ten years at room temperature).
- Insulation resistance: Each terminal to ground terminal: 20 M $\Omega$  or greater (at 500 VDC)
- Dielectric strength: Power supply to ground terminal:  
 1500 VAC (50/60 Hz), 1 minute (except /P1 model)  
 Power supply to ground terminal:  
 500 VAC (50/60 Hz), 1 minute (/P1 model)  
 Contact output terminal to ground terminal:  
 1500 VAC (50/60 Hz), 1 minute  
 Measuring input terminal to ground terminal:  
 1500 VAC (50/60 Hz), 1 minute  
 Between measuring input terminals:  
 1000 VAC (50/60 Hz), 1 minute (except for b-terminal of RTD input of DX106P and DX112P)  
 Between remote control terminal to ground terminal:  
 500 VDC, 1 minute

## 11.8 General Specifications

---

### Safety and EMC Standards

CSA:	Certified by CSA22.2 No. 1010.1, Installation category (Overvoltage category) II <sup>*1</sup> , Pollution degree 2 <sup>*2</sup>
UL:	Certified by UL61010B-B (CSA NRTL/C)
CE:	EMC: Complies with EN61326-1 Complies with EN61000-3-2 Complies with EN61000-3-3
	Low voltage: Complies with EN61010-1, Measurement category II <sup>*3</sup>

\*1 "Installation category (Overvoltage category)" describes a number which defines a transient overvoltage condition. It implies the regulation for impulse withstand voltage. "II" applies to electrical equipment which is supplied from the fixed installation like distribution board.

\*2 "Pollution degree" describes the degree to which a solid, liquid, or gas which deteriorates dielectric strength or surface resistivity is adhering. "2" applies to normal indoor atmosphere. Normally, only non-conductive pollution occurs.

\*3 Applies to measuring circuits connected to low voltage installation, and electrical instruments supplied with power from fixed equipment such as electric switchboards.



## 11.9 Dimensional Drawings

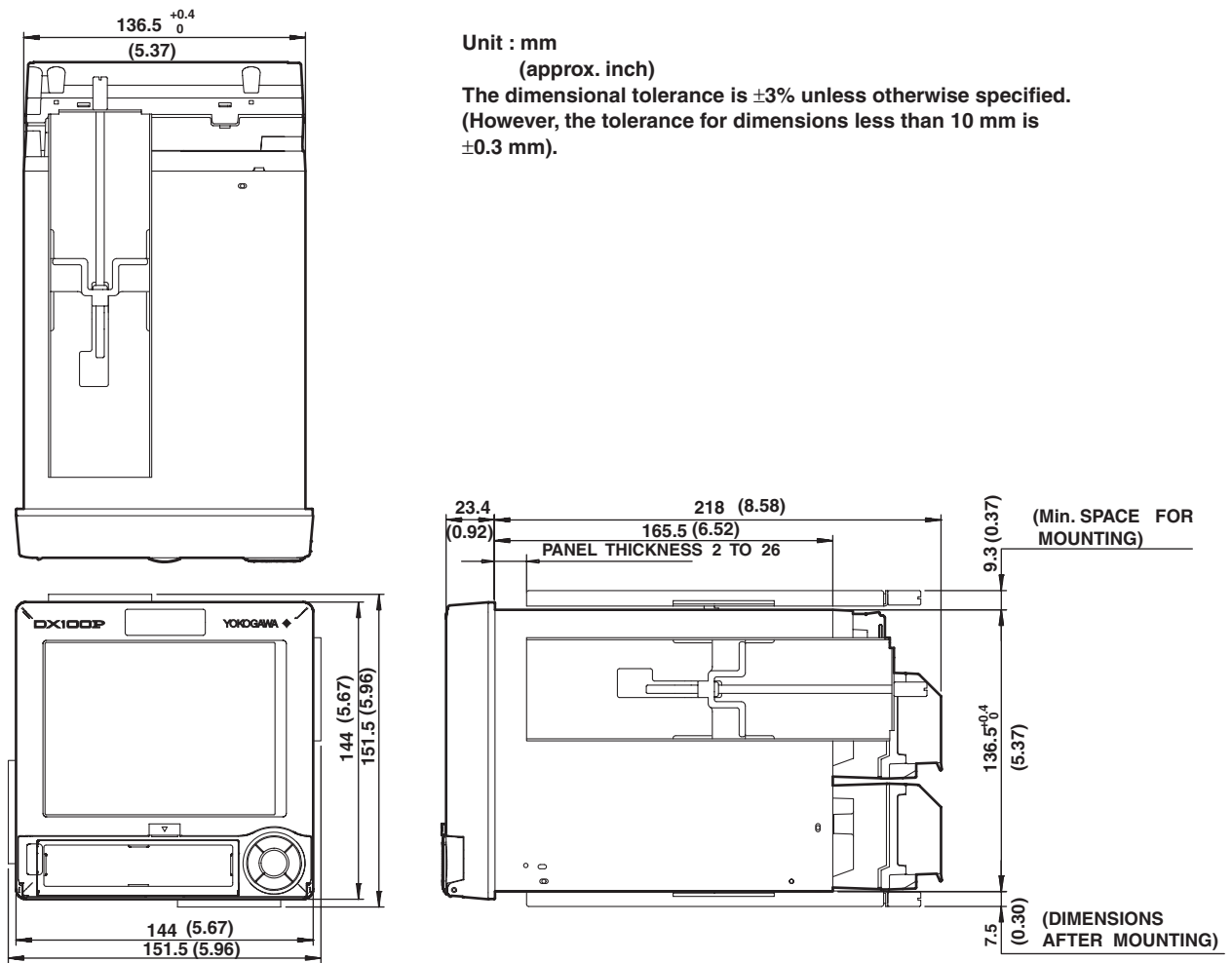

Unit : mm

(approx. inch)

The dimensional tolerance is  $\pm 3\%$  unless otherwise specified.  
(However, the tolerance for dimensions less than 10 mm is  $\pm 0.3$  mm).

### Note

When mounting to a panel, use two brackets, one each of the top and bottom of the DX100P, or on the left and right sides.

Panel Cutout

Single-Unit Mounting

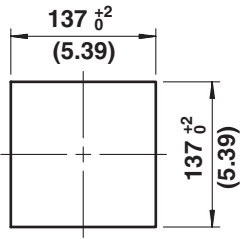

Unit : mm

(approx. inch)

The dimensional tolerance is  $\pm 3\%$  unless otherwise specified. (However, the tolerance for dimensions less than 10 mm is  $\pm 0.3$  mm).

Side-by-Side Mounting (horizontally)

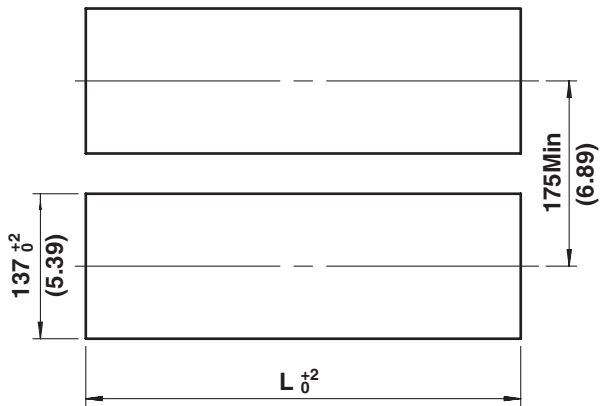

Side-by-Side Mounting (vertically, max. 3units)

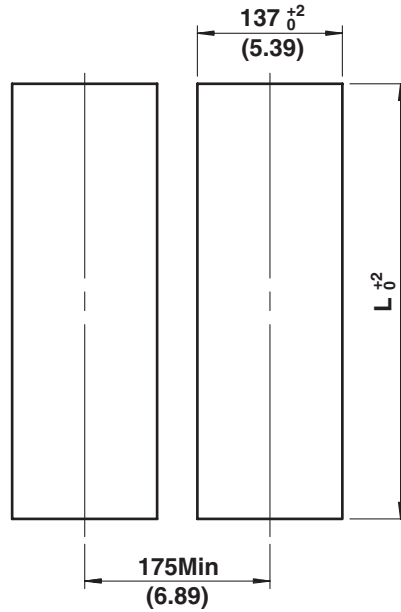

Units	$L_0^{+2}$ (mm)
2	282
3	426
4	570
5	714
6	858
7	1002
8	1146
9	1290
10	1434
n	$(144xn)-6$

Desktop type

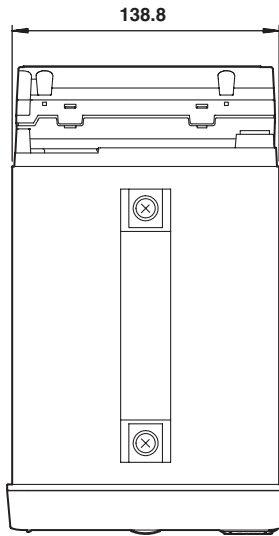

Unit : mm

(approx. inch)

The dimensional tolerance is  $\pm 3\%$  unless otherwise specified.  
 (However, the tolerance for dimensions less than 10 mm is  $\pm 0.3$  mm).

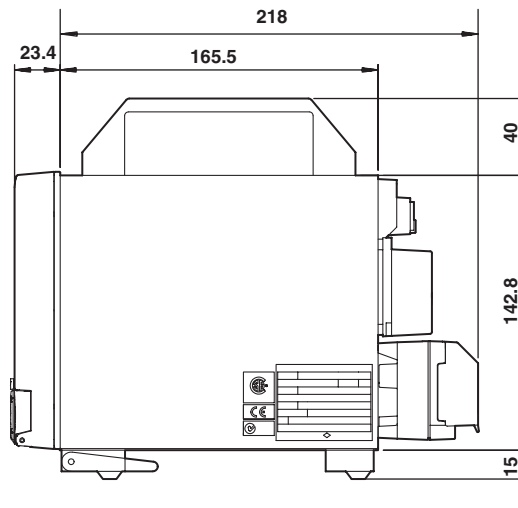
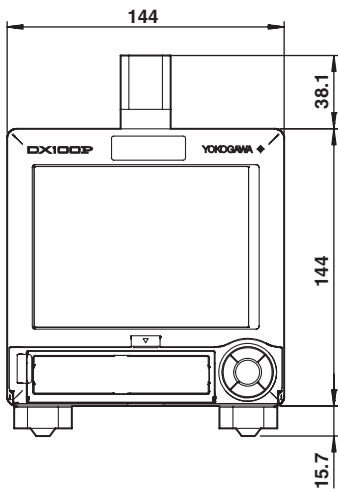

# Appendix 1 Parameters and Initial Settings

## Engineering Mode

Initial settings are thick-framed.

Parameters		Menu				Notes	
Range	Volt	20 mV	60 mV	200 mV	<b>2 V</b>	Other parameters: Upper/lower limits of span	
		6 V	20 V	50 V			
	TC	R	S	B	K		
		E	J	T	N		
		W	L	U			
	RTD	PT	JPT			Other parameters: Upper/lower limits of span	
	Scale	Volt	20 mV	60 mV	200 mV	2 V	Other parameters: Upper/lower limits of span Upper/lower limits of scale
			6 V	20 V	50 V		
		TC	R	S	B	K	
			E	J	T	N	
			W	L	U		
		RTD	PT	JPT			
	DI	Level	Cont				
	Unit					Character string	
	Delta	Volt	20 mV	60 mV	200 mV	2 V	Other parameters: Upper/lower limits of span
			6 V	20 V	50 V		
		TC	R	S	B	K	
			E	J	T	N	
			W	L	U		
		RTD	PT	JPT			
DI	Level	Cont					
Ref. CH					Up to model types		
DI	Level	Cont			Other parameters: Upper/lower limits of span		
Sqrt	Unit	20 mV	60 mV	200 mV	2 V	Other parameters: Upper/lower limits of span Upper/lower limits of scale	
		6 V	20 V	50 V			
Skip					Character string		
Alarm	On/Off	On	<b>Off</b>				
	Type	H	L	h	l		
		R	r	T	t		
	Value					Numerical value	
	Relay On/Off	On	Off				
Number	I01 to I06				Up to model types		
Tag	Tag					Character string, Initial setting is "all space"	
Moving average	Count	<b>Off</b>	2	3	4	DX106P/DX112P	
		5	6	7	8		
		9	10	11	12		
		13	14	15	16		
Filter		<b>Off</b>	2 s	5 s	10 s	DX102P/DX104P	
Alarm delay time		1 to 3600 s	<b>10 s</b>			Numerical value	
Trend/Save interval	Time/div	15 s	30 s	<b>1 min</b>	2 min	15 s and 30 s are for DX102P and DX104P only	
		5 min	10 min	15 min	20 min		
		30 min	1 h	2 h	4 h		
		10 h					
	Auto save interval	10 min to 31 days	<b>1 h</b>			Up to other parameters set Fixed when "Batch" process is set.	
User key	Action	<b>None</b>	Alarm ACK	Math	Math rst		
		M. sample	Message 1	Message 2	Message 3		
		Message 4	Message 5	Message 6	Message 7		
		Message 8	Snapshot				

## Appendix 1 Parameters and Initial Settings

Parameters		Menu				Notes	
Message	Group number	1	2	3	4	Character string, Initial setting is "all space"	
		5	6	7			
	Group name 1 to 8						
Group set	Group number	1	2	3	4	Fixed	
	Group name	GROUP 1	GROUP 2	GROUP 3	GROUP 4	Character string	
		GROUP 5	GROUP 6				
	CH set					See section 5.9 for initial settings.	
	Trip line	On/Off	On	Off			
		Position					Numerical value
Color		Red	Green	Blue	B. violet	Initial settings are No.1: Red, No.2: Green, No.3: Blue, No.4: Yellow	
	Brown	Orange	Y. green	Lightblue			
	Violet	Gray	Lime	Cyan			
	Darkblue	Yellow	Lightgray	Purple			
Color	CH1 to CH30	Red	Green	Blue	B. violet	See section 11.2 for initial settings.	
		Brown	Orange	Y. green	Lightblue		
		Violet	Gray	Lime	Cyan		
		Darkblue	Yellow	Lightgray	Purple		
Zone	Lower	0 to 95				Numerical value	
	Upper	5 to 100					
Graph	Division	4	5	6	7		
		8	9	10	11		
		12	C10				
	Bar graph	Normal	Center				
	Scale position	Off	1	2	3		
		4	5	6			
Partial	On/Off	On	Off				
	Expand	1 to 99				Numerical value	
	Boundary						
View	Direction	Trend	Horizontal	Vertical	Horizon2		
		Bar graph	Horizontal	Vertical			
	Background	White	Black				
	Trend line	1	2	3			
	Trip line	1	2	3			
	Grid	Auto	4	5	6		
		7	8	9	10		
		11	12				
	Scroll	5 s	10 s	20 s	30 s		
		1 min					
Scale digit	Normal	Fine					
LCD	Brightness	1	2	3	4		
		5	6	7	8		
	Backlight saver	On/Off	On	Off			
		Saver time	1 min	2 min	5 min	10 min	
		30 min	1 h				
Restore	Key	Key + Alm					
Math color	CH31 to CH42	Red	Green	Blue	B. violet	See section 11.2 for initial settings.	
		Brown	Orange	Y. green	Lightblue		
		Violet	Gray	Lime	Cyan		
		Darkblue	Yellow	Lightgray	Purple		
Math Zone	Lower	0 to 95				Numerical value	
	Upper	5 to 100					
Math partial	On/Off	On	Off				
	Expand	1 to 99				Numerical value	
	Boundary						

Appendix 1 Parameters and Initial Settings

Parameters		Menu				Notes	
Math Graph	Division	4	5	6	7		
		8	9	10	11		
		12	C10				
	Bar graph	Normal	Center				
	Scale position	Off	1	2	3		
File	Header	4	5	6		Character string, Initial setting is "all space"	
	Directory name					Character string, Initial setting is [DATA 0]	
Save/Load	Save settings						
	Load settings						
	Save data to media						
Time set	YY/MM/DD HH:MM:SS					Numerical value	
	DST	Summer	Winter				
Batch set	Lot number Use/Not	Use	Not				
	Auto increment	On	Off				
	Header	1					Character string
		2					
3							
Math set 1	Math range	On/Off	On	Off			
		Calculation expression					Equation for computation
		Span Lower					Numerical value
		Span Upper					
	Math alarm	Unit					Character string
		On/Off	On	Off			
		Type	H	L	T	t	
		Value					Numerical value
	Relay On/Off	On	Off				
	Number	I01 to I06				Up to model types	
Math set 2	Constant	K01 to K30				Numerical value, Initial setting is "1"	
Math set 3	Tag	Tag				Character string, Initial setting is "all space"	
	TLOG	Timer No.	1	2	3		
		Sum scale	Off	/s	/min	/h	
	Rolling average	On/Off	On	Off			
		Interval	1 s	2 s	3 s	4 s	
			5 s	6 s	10 s	12 s	
			15 s	20 s	30 s	1 min	
			2 min	3 min	4 min	5 min	
			6 min	10 min	12 min	15 min	
			20 min	30 min	1 h		
Number of samples	1 to 64				Numerical value		
	Alarm delay time	1 s to 3600 s	10 s			Numerical value	
Calibration correction setting	Channel					Up to model types	
	Number of set points	Off	2 to 16				
	1 to 16	MES val					Numerical value
True val							

**Appendix 1 Parameters and Initial Settings**

Parameters		Menu				Notes	
Daylight saving time	Use/Not	Use	Not				
	Start time	Month	1 to 12				
		Day order	1	2	3	4	
			Last				
		Weekday	SUN	MON	TUE	WED	
			THU	FRI	SAT		
	Hour of the day					Numerical value 0 to 23	
	End time	Month	1 to 12				
		Day order	1	2	3	4	
			Last				
		Weekday	SUN	MON	TUE	WED	
			THU	FRI	SAT		
Hour of the day					Numerical value 0 to 23		

## System Mode

Initial settings are thick-framed.

Parameters		Menu				Notes	
Alarm	Reflash	On	Off				
	Relay	AND	None	I01	I01 - I02	I01 - I03	Up to model types
			I01 - I04	I01 - I05	I01 - I06		
		Action	Energize	De-energ			
		Behavior	Hold	Nonhold			
	Indicator		Hold	Nonhold			
	Rate of change	Increase	1	2	3	4	
			5	6	7	8	
		Decrease	9	10	11	12	
			13	14	15		
Hysteresis	On	Off					
A/D	Integrate	Auto	50 Hz	60 Hz	100 ms	Initial setting is 50 Hz for models with /P1. 100 ms is for DX106P/DX112P.	
	Scan interval	125 ms	250 ms			DX102P/DX104P	
		1 s	2 s			DX106P/DX112P	
	Burnout set	Off	Up	Down			
	RJC	Internal	External				
	Volt (μV)					Numerical value	
Temperature unit		C	F				
Application	Type of process	Batch	Continu				
	Trend clear	On	Off				
Memory	Data	Display	Event				
	Event	Sample rate	125 ms	250 ms	500 ms	1 s	125 ms, 250 ms, and 500 ms are for DX102P and DX104P only
			2 s	5 s	10 s	30 s	
			60 s	120 s	300 s	600 s	
Data length	3 min to 31 days					Up to other parameters set	
Memory and trend	Meas CH/Math CH	Meas CH	Math CH				
	First-CH					Up to model types	
	Last-CH						
	On/Off	On	Off				
Memory timeup	Timeup type	Off	Hour	Day	Week		
		Month					
	Date					Numerical value	
	Day of the week	SUN	MON	TUE	WED		
		THU	FRI	SAT			
Time (hour)					Numerical value		
Admin tool Batch system settings	Login settings	User ID	Use	Not			
		Use/Not					
		Auto Logout	Off	1 min	2 min	5 min	
	Display change without login	On	Off				
	Sign record settings	Sign record	Use	Not			
		Use/Not					
Batch stop sign record		On	Off				
Sign record	Use	Not					
User ID							
Admin tool Admin settings	Number	1	2	3			
	Login method	Off	Key	Key+Com			
	User name					Character strings	
	User ID						
	Password	????????	*****	-----		Only default password can be entered	
	Password expire	Off	1 month	3 month	6 month		



## Appendix 1 Parameters and Initial Settings

Parameters		Menu				Notes
Admin tool User settings	User Number	1 to 30	31 to 60	61 to 90		
	Number	1 to 30	31 to 60	61 to 90		
	Login method	Off	Key	Com	Key+Com	
	User name					Character strings
	User ID					
	Password	???????	*****	-----		Only default password can be entered
	Password expire	Off	1 month	3 month	6 month	
	Login mode No.	1 to 30				
Calibration correction set	Use	Not				
Admin tool Login mode settings	Number	1 to 30				
	Sign record	Off	sign1	sign2	sign3	
	Key	START	Free	Lock		
		STOP	Free	Lock		
		MENU	Free	Lock		
		USER	Free	Lock		
		DISP/ENTER	Free	Lock		
	Alarm ACK	Free	Lock			
	Media	Free	Lock			
	Batch	Free	Lock			
	Message	Free	Lock			
	Snapshot	Free	Lock			
	Math	Free	Lock			
	Save data	Free	Lock			
	Load data	Free	Lock			
E-mail	Free	Lock				
Other	Free	Lock				
AUX	Tag/Channel	Tag	Channel			
	Memory alarm	Off	1 h	2 h	5 h	
			10 h	20 h	50 h	100 h
	Language	English	Japanese	German	French	
	Partial	Use	Not			
Remote Controller ID	Off	1 to 30				
Media FIFO	On/Off	On	Off			
Save/Load, Initialize	Save settings					
	Load settings					
	Load login settings					
Option Report	Initialize	Clear 1	Clear 2	Clear 3		
	Report set	Off	Hour	Day	Hour + Day	
		Day + Week	Day + Month			
	Date					Numerical value
	Date of the week	SUN	MON	TUE	WEN	
		THU	FRI	SAT		
	Time (hour)					Numerical value
	Report CH	R01	R02	R03	R04	
		R05	R06	R07	R08	
		R09	R10	R11	R12	
On/Off	On	Off				
Channel					Up to model types	
Sum scale	Off	/s	/min	/h		
	/day					

Appendix 1 Parameters and Initial Settings

Parameters		Menu				Notes	
Option Remote	Action NO.1 to NO.8	None	Start Stop	Alatm ACK	Time adj		
		Math	Math rst	M. sample	Message 1		
		Message 2	Message 3	Message 4	Message 5		
		Message 6	Message 7	Message 8	Snapshot		
Option Timer (TLOG) No.1, 2, 3	Mode	Off	Relative	Absolute		Initial setting Timer 1: Absolute Timer 2, 3: Off	
	Interval	(Absolute)	1 min	2 min	3 min	4 min	
			5 min	6 min	10 min	12 min	
			15 min	20 min	30 min	1 h	
			2 h	3 h	4 h	6 h	
			8 h	12 h	24 h		
		(Relative)					Numerical value
	Ref. time					Numerical value, Initial setting is [0:00]	
Reset	On	Off					
Action	Off	Datasave					
Option System relay	1	Fail	Memory	Batch	User locked		
		Login user					
	2	Fail	Memory	Batch	User locked		
		Login user					
Communication Ethernet	IP-address					Numerical value	
	Subnet mask						
	Default gateway						
	DNS On/Off	On	Off				
	Server search order	Primary					Numerical value
		Secondary					
	Host name					Character string	
	Domain name						
	Domain suffix search order	Primary					Character string
		Secondary					
Communication Serial	Baud rate	1200	2400	4800	9600		
		19200	38400				
	Data length	7	8				
	Parity	Even	Odd	None			
	RS-232 Handshaking	Off : Off	XON : XON	XON : RS	CS : RS		
	RS-422A /485 Address	1	2	3	4		
		5	6	7	8		
		9	10	11	12		
		13	14	15	16		
		17	18	19	20		
		21	22	23	24		
		25	26	27	28		
		29	30	31	32		
	Protocol	Normal	Modbus	Modbus-M	Barcode		
Off							
Memory out	Ethernet	Serial					
FTP transfer file	Disp & Event data	On	Off				
	Report	On	Off				
	Snapshot	On	Off				
FTP connection		Primary	Secondary				
	FTP server name					Character string	
	Port number	21				Numerical value	
	Login name					Character string	
	Password						
	Account						
	PASV mode	On	Off				
	Initial pass					Character string	

## Appendix 1 Parameters and Initial Settings

Parameters		Menu				Notes
Application time out	On/Off	On	Off			
	Time	1 to 120 min				Numerical value
Keep alive		On	Off			
Communication input/Available user		Off	Admin1 to User30	Serial		
Web	Use/Not	Use	Not			
	Page type	Operator	Monitor			
	On/Off	On	Off			
	Access control	On	Off			
	User name					Character string
	Password					
Basic E-Mail settings	SMTP server name					Character string
	Port number	25				Numerical value
	Recipient 1					Character string
	Recipient 2					
	Sender					
Alarm E-Mail settings	Recipient 1	On	Off			
	Recipient 2	On	Off			
	Alarm 1	On	Off			
	Alarm 2	On	Off			
	Alarm 3	On	Off			
	Alarm 4	On	Off			
	Include INST	On	Off			
	Include source URL	On	Off			
	Subject	<DX> Alarm_summary				Character string
	Header 1					
	Header 2					
Scheduled E-Mail settings	Recipient 1	On	Off			
	Interval	1	2	3	4	
		6	8	12	24	
	Ref. time	00:00				Numerical value
	Recipient 2	On	Off			
	Interval	1	2	3	4	
		6	8	12	24	
	Ref. time	00:00				Numerical value
	Include INST	On	Off			
	Include source URL	On	Off			
	Subject	<DX> Periodic_data				Character string
Header 1						
Header 2						
System E-Mail settings	Recipient 1	On	Off			
	Recipient 2	On	Off			
	Include source URL	On	Off			
	Subject	<DX> System_warning				Character string
	Header 1					
Header 2						
Report E-Mail settings	Recipient 1	On	Off			
	Recipient 2	On	Off			
	Include source URL	On	Off			
	Subject	<DX> Report_data				Character string
	Header 1					
Header 2						

Appendix 1 Parameters and Initial Settings

Parameters		Menu				Notes	
Communication Modbus master Basic settings	Read cycle	125 ms	250 ms	500 ms	1 s		
		2 s	5 s	10 s			
	Timeout	125 ms	250 ms	500 ms	1 s		
		2 s	5 s	10 s	1 min		
	Retrials	Off	1	2	3		
		4	5	10	20		
Communication Modbus master command settings	On/Off	On	Off				
	First/Last	C01	C02	C03	C04		
		C05	C06	C07	C08		
		C09	C10	C11	C12		
	Address						Numerical value
	Registers						
Type	INT16	UINT16	INT32_B	INT32_L			
Active strage changes	Time change	On	Off				
	User change	On	Off				
	Cal correct change	On	Off				
	Text message on cal correct	On	Off				
Date & Time	Time deviation limit	Off	10s	20s	30s		
		1min	2min	3min	4min		
		5min					
Time zone	Difference from GMT	-1200 to 1200				Numerical value Initial value:0	
SNTP Basic settings	Server settings Use/Not	Use	Not				
	Client settings Use/Not	Use	Not				
	Server name						Character string
	Port number						Numerical value, Initial value:123
	Access interval	Off	1h	8h	12h		
	24						
Access reference time					Numerical value, Initial value: 00:00		
Access timeout	10s	30s	90s				
SNTP synched to start	Time adjust on start action	On	Off				

## Appendix 2 Data Formats of ASCII Files

This section describes the data format of the ASCII file. The DX100P creates three types of ASCII files, the manual sampled data file, the report file, and the change setting file.

### Data Format of the Manual Sampled Data File

- The manual sampled data are output in ASCII format using values and strings that are separated by commas.
- The channel/tag, unit, and manual sampled values are not output for channels in which the input range is set to [Skip] or for which the computation is turned OFF.
- The manual sampled data are appended to the file for each manual sample operation.

#### Syntax

```
"MANUAL SAMPLE DATA" CRLF
"Model Serial No.:", "IIIIIIIIIIIIIIIIIIII" CRLF
"File Header:", "HHHHHHHHHHHHHHHHHHHHHHHHHHHHHHHH" CRLF
"CH/TAG", "cccccccccccccccc", "cccccccccccccccc", ..., "cccccccccccccccc" CRLF
"UNIT", "uuuuuu", "uuuuuu", ..., "uuuuuu" CRLF
yyyy/mo/dd hh:mi:ss, nnn...n, nnn...n, ..., nnn...n CRLF
```

III...I	Serial number of the DX100P (16 characters)
HHH...H	File header (32 characters)
ccc...c	Channel number or tag name (16 characters)
uuuuuu	Unit (6 characters)
yyyy/mo/dd	Date when the setup file is created
hh:mi:ss	Time when the setup file is created
nnn...n	Measured/computed value (measured value: 8 characters, computed value: 10 characters)

#### File Output Example

The following example shows a file that contains manual sampled data from channels 1, 2, 3, and 4.

```
"MANUAL SAMPLE DATA"
"Model Serial No.:", "12A338617"
"File Header : ", "Process1-Lot2"
"CH/TAG", "CH01", "CH02", "CH03", "CH04"
"UNIT", "V", "V", "V", "mV"
2000/01/01 01:08:43, 0.000, 0.000, 0.000, -14.00
2000/01/01 01:08:48, 0.000, 0.000, 0.000, -14.00
2000/01/01 01:09:15, 0.000, 0.000, 0.000, -14.00
"CH/TAG", 1 "CH01", "CH02", "CH03", "CH04"
"UNIT", "V", "V", "V", "V"
2000/01/01 01:15:30, 0.000, 0.000, 0.000, -0.014
2000/01/01 01:18:12, 0.000, 0.000, 0.000, -0.014
```

**Note**

- Output value when detected erroneous data, measurement over range data, or computation overflow data

Channels	Data	Output value
Measurement channels	measurement error	Blank
	positive (+) over range	99999
	negative (-) over range	-99999
Computation channels	computation error	999999999
	positive (+) computation overflow	999999999
	negative (-) computation overflow	-999999999

- CH/TAG and UNIT lines  
 In the following cases, both the CH/TAG line and the UNIT line are rewritten after a carriage return line feed and followed by manual sampled data.
  - When the measurement channel is switched from some setting other than [Skip] to [Skip].
  - When the measurement channel is switched from [Skip] to some other setting.
  - When the computation channels are turned On or turned Off.
  - When the unit is changed.
 Four lines from the bottom of the file example shows the output when the unit for channel 31 is changed from "mV" to "V."

**Data Format of the Report File**

- The hourly, daily, weekly, and monthly reports are output in ASCII format using values and strings that are separated by commas.
- The channel/tag, unit, average value, maximum value, minimum value, and sum value are not output for channels in which the input range is set to [Skip] or for which the computation is turned OFF.
- The report data are appended to the file at each time interval.

**Syntax**

```
"TTT...T REPORT", "START TIME", YYYY/MO/DD HH:MI CRLF
"Model Serial No.:", "IIIIIIIIIIIIIIIIII" CRLF
"File Header:", "HHHHHHHHHHHHHHHHHHHHHHHHHHHHHHHHHH" CRLF
"CH/TAG", "cccccccccccccccc", "cccccccccccccccc", ..., "cccccccccccccccc" CRLF
"UNIT", "uuuuuu", "uuuuuu", ..., "uuuuuu" CRLF
CRLF
yyyy/mo/dd hh:mi, eeeeeeee, eeeeeeee, ..., eeeeeeee CRLF
"AVE", nnnnnnnnnnnnn, nnnnnnnnnnnnn, ..., nnnnnnnnnnnnn CRLF
"MAX", nnnnnnnnnnnnn, nnnnnnnnnnnnn, ..., nnnnnnnnnnnnn CRLF
"MIN", nnnnnnnnnnnnn, nnnnnnnnnnnnn, ..., nnnnnnnnnnnnn CRLF
"SUM", nnnnnnnnnnnnn, nnnnnnnnnnnnn, ..., nnnnnnnnnnnnn CRLF
```

<b>TTT...T</b>	Title (HOURLY, DAYLY, WEEKLY, or MONTHLY)
<b>YYYY/MO/DD</b>	Date the report started
<b>HH:MI</b>	Time the report started
<b>II...I</b>	Serial number of the DX100P (16 characters)
<b>HH...H</b>	File header (32 characters)
<b>ccc...c</b>	Channel number or tag name (16 characters)
<b>uuuuuu</b>	Unit (6 characters)
<b>eeeeeee</b>	Status of the data used
	<b>E</b> Error data
	<b>O</b> Over range or computation overflow
	<b>P</b> Power failure
	<b>C</b> Time change
<b>yyyy/no/dd</b>	Date the report is created
<b>hh:mi</b>	Time the report is created
<b>nnn...n</b>	Report value (13 digits)

**File Output Example**

The following example shows the daily report for four channels.

```
"DAILY REPORT", "START TIME", 2000/01/31 20:00
"Model Serial No.:", "12A338617"
"File Header:", "Process1-Lot2"
"CH/TAG", "CH01", "CH02", "CH03", "CH04"
"UNIT", "V", "V", "V", "V"
2000/01/01 00:00, "C", "C", "C", "C"
"AVE", 0.00, 0.10, 0.20, 0.30
"MAX", 0.00, 1.00, 2.00, 3.00
"MIN", 0.00, -1.00, -2.00, -3.00
"SUM", 0.000000E-01, 1.000000E+04, 2.000000E+04, 3.000000E+04
```

**Note**

- When the measurement and computation channel data enter the condition described in the following table, status “E” and “O” are output in the report.

Data Condition	Status
Common to measurement and computation channels Measurement error or computation error	E
For measurement channels Positive (+) over range	O
Negative (-) over range	O
For computation channels Positive (+) computation overflow (when the value exceeds $3.4E + 38$ )	O
Negative (-) computation overflow (when the value falls below $-3.4E + 38$ )	O

- Measurement/computation errors are discarded when MAX and MIN are determined.
- Measurement/computation errors, over range, and computation overflow are discarded when determining AVE and SUM.
- The report output values of AVE, MAX, MIN and SUM vary depending on the data condition of the measurement and computation channels as shown in the table below.

Item	Data Condition of Measurement Channels	Report Output Value
AVE (Average value)	When all data are measurement errors or over range	(Blank)
MAX, MIN (Maximum value, minimum value)	<ul style="list-style-type: none"> <li>When all data are measurement errors</li> <li>Positive (+) over range</li> <li>Negative (-) over range</li> </ul>	(Blank) 99999 -99999
SUM (Sum value)	<ul style="list-style-type: none"> <li>When all data are measurement errors or over range</li> <li>When the sum value exceeds <math>3.4E + 38</math></li> <li>When the sum value is below <math>-3.4E + 38</math></li> </ul>	(Blank) 9.999999E + 99 -9.999999E + 99

Item	Data Condition of Computation Channels	Report Output Value
AVE (Average value)	When all data are computation errors or over range	(Blank)
MAX, MIN (Maximum value, minimum value)	<ul style="list-style-type: none"> <li>When all data are computation errors</li> <li>When the maximum value exceeds 99999999</li> <li>When the minimum value is below -99999999</li> </ul>	(Blank) 999999999 -999999999

The decimal position that was specified when the span for the equation was specified is reflected in the maximum and minimum values. For example, if the span setting of the equation is “200.0,” then “999999999” is output when the value exceeds “99999999.9” and “-999999999” is output when the value is below “-999999.9.”

SUM (Sum value)	<ul style="list-style-type: none"> <li>When all data are computation errors or computation overflow</li> <li>When the sum value exceeds <math>3.4E + 38</math></li> <li>When the sum value is below <math>-3.4E + 38</math></li> </ul>	(Blank) 9.999999E + 99 -9.999999E + 99
--------------------	--	--



### Data Format of Setting Change Log File

The log of setting changes is output using numerical values and strings in ASCII format delimited by commas.

#### Syntax

```
"Setting Change Log File" CRLF
"Model Serial No.:", "iiiiiiiiiiiiiiii" CRLF
"File Header:", "hhhhhhhhhhhhhhhhhhhhhhhhhhhhhhhhhhhhhhhh" CRLF
CRLF
"Date Time", "No.", "File Name", "Operation", "User Name", "Changed Part" CRLF
yyyy/mo/dd hh:mi:ss, nnnnnnnnn, "ffffff.PPL", "ppp", "uuuuuuuuuuuuuuuuuuuu", "ccc..."
CRLF
```

- iii...i** Serial number of the DX100P (16 characters max.)
- hhh...h** File header (32 characters max.)
- yyyy/mo/dd** Date the setting is changed
- hh:mi:ss** Time the setting is changed
- nnn...n** A number appended in order of occurrence (10 digits)
- fff...f** Name of the setup file (8 characters)
- ppp** Operation type
  - KEY** Key operation
  - MSR** via the Ethernet communications (the setting function of the setting/measurement server)
  - SRL** via the serial communications
- uuu...u** Name of the user who changed the settings (20 characters max.)
- ccc...** Location of the setting change
  - Eng** Engineering mode settings
  - Sys** System mode settings (excluding Login information)
  - Eng/ Sys** Engineering mode and System mode settings (excluding Login information)
  - Login** Login information
  - Sys/Login** System mode (excluding the login information) settings and Login information
  - Eng/Login** Engineering mode setting change and login information setting change
  - All** All setting changes (engineering mode, system mode, and login information)

#### File Output Example

```
"Setting Change Log File"
"Model Serial No.:", "12A338617"
"File Header:", "Process1-Lot2"
"Date Time", "No.", "File Name", "Operation", "User Name", "Changed Part"
2001/06/15 01:23:45, 1, 61501231.PPL, "KEY", "ABC2001", "Sys"
2001/08/01 12:34:56, 2, 80112341.PNL, "KEY", "ope1", "Eng"
2001/08/01 12:40:56, 2, 80112400.PNL, "KEY", "A", "Sys/Login"
```

## Appendix 3 Data Type

Data	Acquisition to the Internal Memory	When Saving to the External File Name.Extension <sup>*1</sup>	Storage Medium Format	Display Using DAQSIGNIN
Display data	Yes	Mddhhmma.DBD	BINARY (Undisclosed)	Yes
Event data	Yes	Mddhhmma.DBE	BINARY (Undisclosed)	Yes
Report data	Yes	Mddhhmma.DHR (hourly) Mddhhmma.DDR (daily) Mddhhmma.DWR (weekly) Mddhhmma.DMR (monthly)	ASCII (see appendix 2)	-
Manual sampled data	Yes	Mddhhmma.DMN	ASCII (see appendix 2)	-
TLOG data	Yes	Mddhhmma.DTG	BINARY (Undisclosed)	Yes
Setup data (specified string).PPL	Yes	Mddhhmma.PPL	BINARY (Undisclosed)	Yes
Setting change log	Yes	Mddhhmma.DPL	ASCII (see appendix 2)	-
Communication log	Yes	-	-	-
FTP log	Yes	-	-	-
Operation error log	Yes	-	-	-
Operation log	Yes	-	-	Yes
Web operation log	Yes	-	-	-
E-mail log	Yes	-	-	-
SNTP log	Yes	-	-	-
Alarm summary	Yes	-	-	-
Message summary	Yes	-	-	-
Screen image data	No	Mddhhmma.PNG	PNG (general format)	-

\*1 About the file name

- Mddhhmm denotes the date and time.  
Mddhhmm of setup data and screen image data is the date and time the file was created.  
Mddhhmm of the setting change log is the date and time the first log was created.  
Mddhhmm of other data is the date and time the first data was sampled.

M: Month (1-9, X (October), Y (November), Z (December)), dd: day, hh: hour, mm: minute

- “a” denote the last digit of the year (0 to 9).

**Example: 70112561.DBD**

Display data file which sampling started on July 1st, 2001 at 12:56.

However, “a” becomes a sequence number for the following case. It takes a value between A and Z.

For example, if the acquisition of the display data is started and stopped within 1 minute and started again by pressing the START key, the two file names are the same up to Mddhhmm (month, day, hour, and minute). In this case, the second file is assigned the sequence number A.

**Example: 70112561.DBD**

**7011256A.DBD**

Two display data files which sampling started on July 1st, 2001 at 12:56.

# Appendix 4 Time for Acquiring Display Data/ Event Data to the Internal Memory

## Number of Data Points That Can Be Acquired to the Internal Memory and Acquisition Time

This section describes the number of display data and event data points that can be acquired to the internal memory and the acquisition time. The information can be used to estimate the time until the internal memory becomes full or used to determine the number of channels and sampling interval for saving the data.

For the auto save interval of display data and data length of event data, selectable range of values are assigned to the soft keys and displayed based on the information described here.

### Number of Bytes per Channel

Display data consists of minimum and maximum values for each sampling interval.

Event data consists of instantaneous values.

The number of data bytes per channel is shown in the following table.

Data Type	Measurement Channel	Computation channel
Display data	4 bytes/channel	8 bytes/channel
Event data	2 bytes/channel	4 bytes/channel

**Example:** Data size when acquiring the data of channels 1 to 4 (measurement channels) and channel 31 (computation channel) to the internal memory.

#### Display data

1st scan

CH1 min	CH1 max	CH2 min	CH2 max	CH3 min	CH3 max	CH4 min	CH4 max	CH31 min	CH31 max	Date & Time (8 bytes)
------------	------------	------------	------------	------------	------------	------------	------------	-------------	-------------	--------------------------

2nd scan

CH1 min	CH1 max	CH2 min	CH2 max	CH3 min	CH3 max	CH4 min	CH4 max	CH31 min	CH31 max	Date & Time (8 bytes)
------------	------------	------------	------------	------------	------------	------------	------------	-------------	-------------	--------------------------

to  
nth scan

CH1 min	CH1 max	CH2 min	CH2 max	CH3 min	CH3 max	CH4 min	CH4 max	CH31 min	CH31 max	Date & Time (8 bytes)
------------	------------	------------	------------	------------	------------	------------	------------	-------------	-------------	--------------------------

2 bytes (binary data)

#### Event data

1st scan

CH1	CH2	CH3	CH4	CH31	Date & Time (8 bytes)
-----	-----	-----	-----	------	--------------------------

2nd scan

CH1	CH2	CH3	CH4	CH31	Date & Time (8 bytes)
-----	-----	-----	-----	------	--------------------------

to  
nth scan

CH1	CH2	CH3	CH4	CH31	Date & Time (8 bytes)
-----	-----	-----	-----	------	--------------------------

2 bytes (binary data)

**Internal Memory Size**

The size of the internal memory for acquiring display data or event data is fixed to 5 MB.

**Maximum Sampling Count**

When the type of data, the number of measurement channels, and the number of computation channels that are to be acquired to the internal memory are determined, the maximum number of times data can be acquired can be derived from the internal memory size. This value is called the maximum sampling count.

The maximum sampling count can be derived from the equations in the following table.

<b>Data to Be Saved</b>	<b>Maximum Sampling Count</b>
Display data	$5,000,000 \text{ bytes} / (\text{number of measurement channels} \times 4 + \text{number of computation channels} \times 8 + 8)$
Event data	$5,000,000 \text{ bytes} / (\text{number of measurement channels} \times 2 + \text{number of computation channels} \times 4 + 8)$

**Maximum Sampling Length**

The maximum sampling length can be determined from the time it takes to acquire the maximum sampling count of data to the internal memory using the following equation.

$$\text{Maximum sampling length} = \text{maximum sampling count} \times \text{sampling interval}$$

**Calculation Example of Maximum Sampling Count and Maximum Sampling Length**

• **Display Data**

**Measurement channels: 2, computation channels: none**

$$\begin{aligned} \text{Maximum sampling count} &= 5,000,000 / (2\text{CH} \times 4 \text{ bytes} + 0 \times 8 \text{ bytes} + 8 \text{ bytes}) \\ &= 312,500 \end{aligned}$$

When the display update rate is 30 min/div (60 s sampling interval)

$$\text{Maximum sampling length} = 312,500 \text{ data points} \times 60 \text{ s} = 18,750,000 \text{ s (approx. 217 days)}$$

**Measurement channels: 12, computation channels: 6**

$$\begin{aligned} \text{Maximum sampling count} &= 5,000,000 / (12\text{CH} \times 4 \text{ bytes} + 6 \times 8 \text{ bytes} + 8 \text{ bytes}) \\ &= 48,076 \end{aligned}$$

When the display update rate is 30 min/div (60-s sampling interval)

$$\text{Maximum sampling length} = 48,076 \text{ data points} \times 60 \text{ s} = 2,884,560 \text{ s (approx. 33 days)}$$

• **Event Data**

**Measurement channels: 4, computation channels: none**

$$\begin{aligned} \text{Maximum sampling count} &= 5,000,000 / (4 \text{ CH} \times 2 \text{ bytes} + 0 \times 4 \text{ bytes} + 8 \text{ bytes}) \\ &= 312,500 \end{aligned}$$

When the sampling interval of event data is 1 s

$$\text{Maximum sampling length} = 312,500 \text{ data points} \times 1 \text{ s} = 312,500 \text{ s (approx. 86 hours)}$$

**Measurement channels: 12, computation channels: 6**

$$\begin{aligned} \text{Maximum sampling count} &= 5,000,000 / (12 \text{ CH} \times 2 \text{ bytes} + 6 \times 4 \text{ bytes} + 8 \text{ bytes}) \\ &= 89,285 \end{aligned}$$

When the sampling interval of event data is 1 s

$$\text{Maximum sampling length} = 89,285 \text{ data points} \times 1 \text{ s} = 89,285 \text{ s (approx. 24 hours)}$$

## Appendix 5      Operation Log Contents and Display

Each operation is displayed in the operation log as follows.

Operation Log	Operation	Ref. section
Login	Logging in	6.1
Logout	Logging out	6.1
UserLocked	The user is invalidated.	6.1, 6.3
MemStart	Memory Start	6.2
MemStop	Memory Stop	6.2
AlarmACK	Releasing the alarm indication and output relay	7.3, 8.11
Message	Writing a message	8.2
Manual	Manual sampling	8.3
MathStart	Starting the computation	8.4
MathStop	Stopping the computation	8.4
MathReset	Resetting the computation	8.4
MathACK	Clearing the comoutation dropout display	8.4
Snapshot	Saving the screen image	8.5
MailStart	Starting the e-mail transmission	IM04L05A01-17E
MailStop	Stopping the e-mail transmission	IM04L05A01-17E
DispSave	Saving the display data	8.6
EventSave	Saving the event data	8.6
DispLoad	Loading the display data	8.7
EventLoad	Loading the event data	8.7
NewTime	Newly set time when data acquisition is stopped	5.15
TimeChg	Setting the date and time using operation keys	5.15
TimeAdj	Adjusting the internal clock via the remote control function	1.9
TimeDST	Time changed according to DST (before change)	1.10
TRevStart	Starting time adjustment while data acquisition is in progress	1.10
TRevEnd	Ending time adjustment	1.10
SNTPtimeset	Adjusting the time at once using SNTP	IM04L05A01-17E
Clear1	Executing Clear 1 Initialization	4.13
Clear2	Executing Clear 2 Initialization	4.13
Clear3	Executing Clear 3 Initialization	4.13
LoginLoad	Loading the login information	4.12
PowerOff	The power is turned Off.	3.1
PowerOn	The power is turned On.	3.1
BatchNoSet	Setting the batch number	6.2, 8.1
LotNoSet	Setting the lot number	6.2, 8.1
UserLocked	The user is invalidated during the operation of the DAQSIGNIN.	IM04L05A01-61E
EngLoad	Loading the setup data on the engineering mode	5.22
SysLoad	Loading the setup data <sup>*1</sup> on the system mode	4.11
EngSet	Changing the engineering mode setup data	Chapter 5
SysSet	Changing the system mode setup data <sup>*1</sup>	Chapter 4
LoginSet	Changing the login information	4.4
Log&SysSet	Changing the system mode setup data <sup>*1</sup> and the login information	Chapter 4
Eng&SysSet	Changing the engineering mode and the system mode setup data <sup>*1</sup>	Chapters 4 and 5
Log&EngSet	Changing the engineering mode settings and login information settings	4.4, Chaptre 5
AllSet	Changing the engineering mode settings, system mode settings <sup>*1</sup> , and login information settings	Chaptres 4 and 5
CCSet##	Changing the number of set points for the calibration correction settings while data acquisitionis in progress (##: Channel number)	5.21
CCSet##	Changing the true values for the calibration correction settings while data acquisition is in progress (##: Channel number)	5.21

\*1 Excludes the login information.

Operation Log	Operation	Ref. section
EngSave	Saving the setup data on the engineering mode	5.23
SysSave	Saving the setup data on the system mode	4.11
Error###	Error operation (###: Error code)	Chapter 9
Warning###	Warning (###: Code)	Chapter 9
UsrLockACK	Clearing the User Locked icon	6.1, 8.12
ChgPasswd	Changing the password	8.10
ConctClose	Being closed by the maintenance/test server	IM04L05A01-17E
FileGet	Getting files	IM04L05A01-17E
FilePut	Putting files	IM04L05A01-17E
MemorySave	Executing the data save operation of the internal memory while data acquisition is stopped	5.24
A/DCalDisp	Entering the AD calibration mode <sup>*2</sup>	-
A/DCalExec	Executing the AD calibration <sup>*2</sup>	-

\*2 For maintenance purposes. The operating procedure is not described in this manual.

**Detailed Display of the Operation Logs**

- CCSet###: Changing the number of set points for the calibration correction settings while data acquisition is in progress

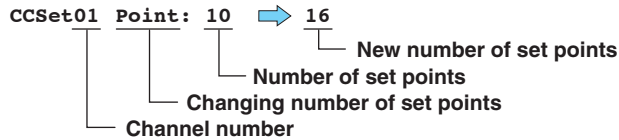

- CCSet###: Changing the true values for the calibration correction settings while data acquisition is in progress

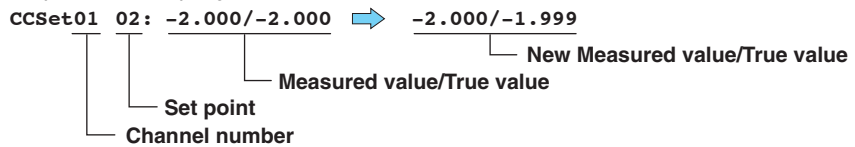

- TRevStart: Starting time adjustment while data acquisition is in progress

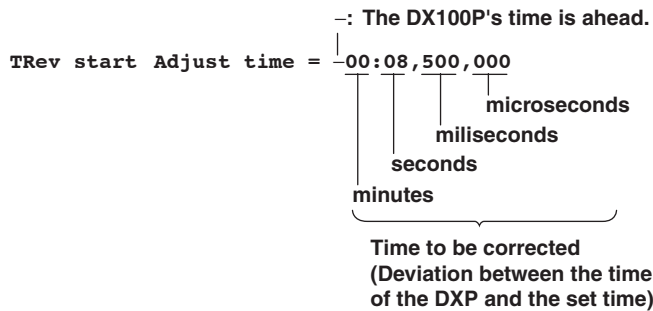

- Error###: Error operation, Warning###: Warning Messages are displayed.

Error 210 Media has not been inserted.  
Warning 601 Measured data have been initialized.

---

## Appendix 6 Style Numbers and Functions

This section describes the relationship between the style numbers and the functions that have been added or changed

The style number "S1" is not applied to the DX100P.

### Style Number S3

- Easy text entry (/KB1, /KB2 options)
- Key operations to enter characters is changed.

### Style Number S4

- Calibration correction (/CC1 option)
- Ethernet communications
  - Registered users can logs into the DX100P.
  - Setting/measurement server (setting function and the monitor function)
  - FTP client
    - Transfers screen image data files at snapshot
  - Maintenance/test server (setting function and the monitor function)
- Serial communications (/C2, /C3 options)
  - Setting/measurement function
  - Barcode input
- Display update rate
  - [15 min] is added.
- Administrator, User
  - Login method: key operations or via the Ethernet
  - Password: 6 to 8 alphanumeric characters
- Historical trend screen
  - Displays time at the cursor position
- DAQSIGNIN
  - Communicator is added.
    - Receives the setup data from and sends the setup data to the DX100P via the Ethernet communications.

### Style Number S5

- Setup operation while data acquisition is in progress is possible.
  - Register administrators and users, set the calibration correction (/CC1 option), change the time
- Detailed display of the operation logs
- Calibration correction (/CC1 option)
  - Settings can ne changed while data acquisition is in progress.
  - A message is written when calibration correction settings is changed while data acquisition is in progress.
  - Consecutive channels can be set at once.
  - User settings related to the calibration correction is revised.
- Setup file and setting change log file can be transferred to an FTP server.
- An e-mail message when a user is locked due to password failure can be transmitted.
- System relay
  - Can output the user locked condition
  - Can output the presence of login users
- Cyclical use of the storage area of the external storage medium (Media FIFO) is possible.

- Operation screen can be switched when logged out.
- Registration of administrators and users
  - Registration is enable while data acquisition is in progress.
  - Up to 90 users can be registered.
- Time change while data acquisition is in progress
  - Time on the DX100P is adjusted by 1/64 s for each second.
- Data in the internal memory can be saved to a external storage medium using key operations when data acquisition is stopped
- Opearions when the login function is not used
  - Setup data in the engineering mode can be changed while data acquisition is in progress.
  - ACK operation of individual alarms, and write operation of free messages are possible on the operator page.
- Communication interface
  - SNTP server and SNTP client functions
    - Operates as an SNTP server.
    - Synchronizes to the time of an SNTP server on the network.
  - Users can use a portion of the control commands (logging into the setting function)
  - A portion of the control commands can be used via the serial interface (logging into the setting function)
  - Output commands can be executed using the barcodes.
  - Operation logs that meets specified conditions can be output.
  - Login status is added to the status informatiom.
  - New commands
    - RG, XC, RC, WA, WB, WC, CL, LO, FI
    - LL (for the serial interface)
- DAQSIGNIN
  - Data files saved using key operations are so indicated.
  - Parameters for revised functions are added.
  - New messages are added



# Index

## A

abnormality in the data ..... 1-47, 1-49  
absolute mode ..... 1-46  
absolute value ..... 1-43  
access indicator ..... 2-4  
accessories (sold separately) ..... vi  
accessories (standard) ..... v  
acquiring data ..... 1-21  
acquisition time ..... App-16  
active storage change ..... 4-30  
adjusting the internal clock (remote control) ..... 1-53  
administrator ..... 1-32  
alarm ..... 1-39  
alarm (computation) ..... 1-45  
alarm ack ..... 8-17  
alarm ack (remote control) ..... 1-53  
alarm ack summary ..... 1-13, 7-10  
alarm hysteresis ..... 1-40  
alarm icon ..... 8-17  
alarm indication ..... 1-10, 1-12, 1-41  
alarm output relay ..... 1-41  
alarm summary ..... 1-12, 7-10  
all channel display ..... 1-8, 7-4  
AND/OR ..... 1-42  
application ..... 4-5  
arithmetical operations ..... 1-43  
ASCII file ..... App-10  
audit trail function ..... 1-31, 1-35  
auto logout ..... 1-32  
auto save ..... 1-24  
auto switching of groups ..... 7-4  
automatic increment of the lot number ..... 1-34  
automatic switching of displayed group ..... 5-24

## B

background color ..... 1-19  
backlight saver ..... 1-19  
bar graph screen ..... 1-11, 7-6  
base position ..... 1-11, 5-23  
batch ..... 1-22  
batch function ..... 1-34  
batch information ..... 1-34  
batch number ..... 8-1  
batch screen ..... 8-1  
batch start/batch stop (remote control) ..... 1-53  
brightness ..... 1-19  
burnout ..... 1-4

## C

calibration ..... 10-3  
calibration correction ..... 1-4  
calibration correction set ..... 4-13  
carrying handle ..... 2-5  
cautions (messages) ..... 9-12  
Celsius ..... 4-4  
changing the password ..... 8-16  
channel display color ..... 5-16  
channel number display ..... 1-6  
channels for saving the display data / event data ..... 1-21  
channels to acquire the data ..... 4-6

clear ..... 3-15  
clear computed results (remote control) ..... 1-54  
clearing the computation dropout display ..... 8-7  
comment ..... 8-2  
common logarithm ..... 1-43  
communication function ..... 1-1  
communication input data ..... 1-43  
computation channels ..... 1-43  
computation data dropout ..... 1-44, 8-7  
computation function ..... 1-43  
computation operators  
- ..... 5-34  
+ ..... 5-34  
.EQ ..... 5-35  
.GE ..... 5-35  
.GT ..... 5-35  
.LE ..... 5-35  
.LT ..... 5-35  
.NE ..... 5-35  
/ ..... 5-34  
ABS ..... 5-34  
AND ..... 5-35  
EXP ..... 5-34  
LOG ..... 5-34  
NOT ..... 5-36  
OR ..... 5-36  
SQRT ..... 5-34  
TLOG.AVE ..... 5-37  
TLOG.MAX ..... 5-37  
TLOG.MIN ..... 5-37  
TLOG.P-P ..... 5-37  
TLOG.SUM ..... 5-37  
XOR ..... 5-36  
\* ..... 5-34  
\*\* ..... 5-34  
conditions of the remote control terminals ..... 1-44  
constants ..... 1-43  
contact specifications (alarm) ..... 2-13  
contact specifications (FAIL/memory end) ..... 2-14  
continuous ..... 1-22  
copy ..... 3-15  
cursor ..... 7-13  
cyclical use of the storage area ..... 1-28

## D

daily report ..... 1-48  
DAQSIGNIN software ..... 1-1  
data acquisition (event data) ..... 1-20  
data acquisition (manual sampled data) ..... 1-26  
data acquisition (report data) ..... 1-27  
data acquisition (TLOG data) ..... 1-26  
data formats of ASCII files ..... App-10  
data length ..... 4-8  
data save destination directory ..... 1-23  
data storage while data acquisition is stopped ..... 1-30  
data type ..... 1-20, App-15  
data used in computation ..... 1-43  
daylight savings time ..... 1-57  
DC voltage ..... 1-2  
default password ..... 6-1  
delay lower limit alarm ..... 1-39  
delay upper limit alarm ..... 1-39  
detailed display of the operation logs ..... App-19

## Index

details of the operation log ..... 8-13  
difference ..... 1-3  
difference lower limit alarm ..... 1-40  
difference upper limit alarm ..... 1-40  
digital input ..... 1-2  
digital screen ..... 1-10, 7-5  
digits of the scale values ..... 5-23  
dimensional drawings ..... 11-21  
display conditions of the LCD ..... 1-19  
display direction (bar graph) ..... 1-11  
display direction (trend) ..... 1-8  
display the log screen ..... 8-13  
display update rate ..... 1-7  
displayed color (bar graph) ..... 1-11  
displayed color (trend) ..... 1-8  
displayed color (trip line) ..... 5-15  
displayed data of the waveform ..... 1-8  
displayed language ..... 1-55  
displaying the list of files ..... 8-12  
displaying the system screen ..... 8-13

## E

easy text entry ..... 1-58  
edge ..... 1-54  
eject button ..... 2-4  
electronic signature function ..... 1-31, 1-37  
energize/de-energize (alarm output relay) ..... 1-42  
engineering mode ..... 3-4  
entering characters ..... 3-23  
entering numbers ..... 3-22  
error messages ..... 9-1  
error on the storage medium ..... 1-29  
ESC key ..... 2-4  
Ethernet port ..... 2-5  
executing memory stop ..... 6-5  
expanding/reducing the time axis ..... 7-14  
exponent ..... 1-43  
external storage media (handling) ..... 2-2  
external storage medium ..... 1-23, 1-28

## F

Fahrenheit ..... 4-4  
fail output ..... 1-51  
FAIL/memory end output ..... 1-51, 1-52  
FIFO ..... 1-28  
FIFO operation of the storage media ..... 4-32  
file information ..... 6-9, 8-11  
file name ..... App-15  
filter ..... 1-5  
flash memory card ..... 3-2  
foot ..... 2-5  
format type of the external storage media ..... 3-3  
free space on the external storage medium ..... 8-12  
front cover ..... 2-3  
front panel ..... 2-3  
FUNC key ..... 3-5  
function setup example ..... 3-18  
functional ground terminal ..... 2-5  
functions when the login function is not used ..... 1-38

## G

grid ..... 1-8, 5-25  
group display ..... 1-6, 7-4

## H

H ..... 5-5  
handling precautions ..... 2-1  
historical trend ..... 1-16, 7-12  
hold/non-hold (alarm output relay) ..... 1-42, 8-17  
hourly report ..... 1-48  
how to write equations ..... 5-34

## I

id number ..... 3-25  
information saved ..... 1-23  
initial settings (engineering mode) ..... App-1  
Initial settings (system mode) ..... App-5  
initial settings of the groups ..... 5-15  
initialize ..... 4-29  
input specifications (remote control) ..... 2-15  
input terminals ..... 2-5  
input type ..... 1-2  
insert and remove the external storage medium ..... 3-2  
installation ..... 2-6, 2-7  
integration time ..... 1-5  
interval (rate-of-change alarm) ..... 1-40

## K

key ..... 2-4  
key operations (engineering mode) ..... 3-13  
key operations (system mode) ..... 3-16  
key panel cover ..... 2-3

## L

label ..... 2-3  
LCD ..... 1-6  
LCD screen ..... 2-3  
loading setup data (engineering mode) ..... 5-44  
loading setup data (system mode) ..... 4-26  
log ..... 1-31  
log (communication command) ..... 8-15  
log (e-mail) ..... 8-15  
log (error message) ..... 8-14  
log (FTP) ..... 8-15  
log (operation) ..... 8-14  
log (setting change) ..... 8-14  
log (web operation) ..... 8-15  
log in via the Ethernet ..... 1-34  
log screen ..... 1-55  
logging in ..... 6-1  
logging out ..... 6-3  
logical computation ..... 1-43  
login ..... 1-31  
login function ..... 1-32  
login information ..... 1-33  
login method ..... 1-32, 1-33  
login mode ..... 4-13  
logout ..... 1-31  
lot number ..... 8-1  
lower limit alarm ..... 1-39  
lower limit on rate-of-change alarm ..... 1-40

**M**

MAC address .....	1-57
maintenance .....	10-1
manual sampled data .....	1-20
manual sampled data file (Data format) .....	App-10
manual sampling .....	8-5
manual sampling (remote control) .....	1-54
measurable range .....	5-3
measurable range (difference computation) .....	5-4
measurement channels .....	1-2
media FIFO .....	1-28
memory end output .....	1-51
memory information .....	7-14
memory start .....	1-31
memory start/stop output .....	1-51
memory stop .....	1-31
memory summary .....	1-15, 7-11
memory timeout .....	1-24, 4-7
menu (engineering mode) .....	3-8
menu (system mode) .....	3-10
MENU key .....	2-4
message .....	1-8, 1-9
message summary .....	1-14, 7-10
model .....	iv
monthly report .....	1-48
moving average .....	1-5

**N**

number of alarms .....	1-39
number of bytes per channel .....	App-16
numerical display (computation channel) .....	1-45
numerical display (measurement channel) .....	1-10
numerical display (report) .....	1-50
numerical display section .....	1-8

**O**

operation log .....	1-35, 6-8, App-18
operation mode .....	3-4
operation of gradually correcting the time .....	1-56
operations that can be carried out when logged out .....	1-32
option terminals .....	2-5
order of precedence of the operators .....	1-44
over display range (computation) .....	1-45
over range .....	1-10
over range (measurement) .....	1-4, 1-49
overflow .....	1-45
overview screen .....	1-12, 7-8

**P**

panel cutout .....	11-21
partial expanded display .....	1-8, 1-9
password .....	1-33
password invalidation .....	6-10, 8-16
periodic maintenance .....	10-1
power (computation) .....	1-43
power supply .....	2-18, 2-19
power supply for transmitter .....	1-58
power switch .....	2-4
power terminals .....	2-5
presence of login users output .....	1-52
protective ground terminal .....	2-5

**R**

range (computation channel) .....	5-31
range (scaling) .....	5-2
reading values using the cursor .....	7-13
rear panel .....	2-5
reference junction compensation .....	1-4
reflash .....	1-41
registering an administrator .....	4-10
registering users .....	4-12
relational computation .....	1-43
relative mode .....	1-46
remote control function .....	1-53
remote control terminal .....	3-25
remote controller id .....	3-24
remote input signal .....	1-54
removing zip disk .....	3-3
replacement periods for worn parts .....	10-5
replacing the fuse .....	10-2
report data .....	1-20, 7-11
report data display .....	1-15
report file (data format) .....	App-12
report function .....	1-48
reset action (TLOG) .....	1-47
resetting the computation .....	8-7
resistance temperature detector .....	1-2
RJC .....	1-4
rolling average .....	1-45
RTD .....	1-2
rules for writing an equation (common items) .....	5-37
run mode .....	3-4

**S**

sample rate .....	4-6
sampling interval (display data) .....	1-21
sampling interval (event data) .....	1-21, 4-6
saving data .....	1-23
saving data via Ethernet .....	1-30
saving setup data (engineering mode) .....	5-43
saving setup data (system mode) .....	4-25
saving the data in the internal memory .....	5-45
saving the setup file .....	1-36
scale .....	5-21
scale (bar graph) .....	1-11
scale (trend) .....	1-8
scale display position .....	5-21
scale marks .....	5-22
scale values .....	5-22
scaling .....	1-3
scan interval .....	1-2
scrolling the waveforms .....	7-13
serial interface port .....	2-5
serial number .....	v
setting	
active storage change .....	4-30
administrator .....	4-10
alarm .....	5-5
alarm (computation channel) .....	5-32
alarm delay period .....	5-9
auxiliary alarm function .....	4-1
background color .....	5-24
backlight saver .....	5-26
base position of the bar graph .....	5-19
batch information .....	5-29
brightness .....	5-26
burnout .....	4-3

## Index

- calibration correction ..... 5-40
  - channel display colors ..... 5-16
  - channels to display the trend and acquire the data ..... 4-6
  - constants ..... 5-33
  - directory name ..... 5-12
  - display direction ..... 5-24
  - display language ..... 4-22
  - display update rate ..... 5-10
  - display/event data acquisition ..... 4-5
  - electronic signature function ..... 4-9
  - file header ..... 5-12
  - grid ..... 5-24
  - groups ..... 5-14
  - input filter ..... 5-8
  - integration time ..... 4-3
  - line width of the trip line ..... 5-24
  - line width of the waveform ..... 5-24
  - login function ..... 4-9
  - measuring range ..... 5-1
  - media FIFO ..... 4-32
  - memory alarm time ..... 4-22
  - message string ..... 5-28
  - moving average ..... 5-8
  - number of digits of the scale ..... 5-24
  - partial expanded display ..... 4-22, 5-17
  - reference junction compensation ..... 4-3
  - remote control functions ..... 4-16
  - remote controller id ..... 4-22
  - report function ..... 4-17
  - rolling average ..... 5-39
  - scale ..... 5-19
  - scan interval ..... 4-3
  - scroll time ..... 5-25
  - sum scale ..... 5-38
  - system relays ..... 4-21
  - tag name ..... 5-7
  - tag/channel display ..... 4-22
  - temperature unit ..... 4-4
  - time deviation limit ..... 4-31
  - time zone ..... 4-24
  - timer ..... 4-19
  - timer number ..... 5-38
  - trip line ..... 5-14
  - USER key ..... 5-13
  - users ..... 4-12
  - zone display ..... 5-17
  - setting change log ..... 1-36
  - setting change log file (data format) ..... App-14
  - setting functions ..... 3-7
  - setting items (engineering mode) ..... 3-8
  - setting items (system mode) ..... 3-10
  - setup operation while data acquisition is in progress ..... 3-6
  - sign authority level ..... 1-38
  - sign record screen ..... 1-17
  - signing ..... 6-6
  - signing display/event data files ..... 8-10
  - snap shot ..... 1-58, 8-8
  - snap shot (remote control) ..... 1-54
  - SNTP log ..... 8-15
  - soft keys ..... 2-4
  - specifications
    - 24 VDC power supply for transmitter ..... 11-14
    - 24 VDC/AC power supply ..... 11-13
    - 3 terminal isolated RTD input ..... 11-13
    - alarm ..... 11-7
    - alarm output relays ..... 11-11
    - calibration correction ..... 11-13
    - clamped input terminal ..... 11-12
    - communication (Ethernet) ..... 11-10
    - computation functions ..... 11-12
    - Cu10, Cu25 RTD input ..... 11-13
    - data management ..... 11-8, 11-9
    - data storage ..... 11-5
    - desktop type ..... 11-12
    - dimensional drawings ..... 11-21
    - display ..... 11-3
    - easy text entry ..... 11-15
    - FAIL/memory end output ..... 11-11
    - general ..... 11-16
    - input ..... 11-1
    - normal operating conditions ..... 11-18
    - power supply ..... 11-17
    - remote control ..... 11-14
    - serial communication interface ..... 11-11
    - standard operation conditions ..... 11-16
    - speed of movement of waveforms ..... 1-7, 5-10
    - square root ..... 1-3, 1-43
    - square-root computation ..... 1-3
    - stacks ..... 5-37
    - START key ..... 2-4
    - start/stop computation (remote control) ..... 1-53
    - starting/stopping computation ..... 8-6
    - statistical computation ..... 1-43
    - status (report) ..... 1-49
    - status display section ..... 1-6, 1-18
    - status messages ..... 9-11
    - STOP key ..... 2-4
    - storage function ..... 1-20
    - storage medium drive ..... 2-4
    - style number ..... i
    - style number S5 ..... App-20
    - sum scale (report) ..... 1-48
    - sum scale (TLOG) ..... 1-46
    - switching the screen ..... 7-2
    - system errors ..... 9-12
    - system mode ..... 3-4
    - system relay ..... 2-14
    - system screen ..... 1-57
- ## T
- tag display ..... 1-6
  - temperature unit ..... 1-57
  - thermocouple ..... 1-2
  - time change function ..... 1-56
  - time deviation limit for time correction ..... 4-31
  - time zone ..... 4-24
  - timer mode ..... 1-46
  - timeup ..... 4-7
  - TLOG computation ..... 1-46
  - TLOG data ..... 1-20, 1-45
  - trend clear ..... 4-5
  - trend screen ..... 1-7, 7-3
  - trigger ..... 1-54
  - trip line ..... 1-8
  - troubleshooting ..... 9-13
  - turning off the power ..... 3-1
  - turning on the power ..... 3-1
  - type of process ..... 1-22
  - types of computations ..... 1-43
  - types of users ..... 1-32
- ## U
- unit (computation) ..... 5-31

unit (scale) .....	5-23
unit (scaling) .....	5-3
unit handling .....	1-44
updating (bar graph) .....	1-11
updating (digital) .....	1-10
updating (overview) .....	1-12
updating (trend) .....	1-7
upper limit alarm .....	1-39
upper limit on rate-of-change alarm .....	1-40
user .....	1-33
user ID .....	1-33
USER key .....	1-55, 2-4
user locked .....	1-33, 6-3
user locked condition output .....	1-52
user locked icon .....	6-3, 8-18

## V

---

version number .....	1-57
----------------------	------

## W

---

waveform lines .....	1-8
weekly report .....	1-48
wiring (alarm output) .....	2-12
wiring (FAIL/memory end) .....	2-14
wiring (input signal) .....	2-8
wiring (power supply) .....	2-18
wiring (remote control) .....	2-15
wiring (transmitter power supply) .....	2-16
writing messages (remote control) .....	1-54
writing messages strings .....	8-3

## Z

---

zip disk .....	3-2
zone display .....	1-8, 1-9